

PAPER • OPEN ACCESS

## Experimental study of fire propagation on sloped roof with building applied photovoltaics

To cite this article: Reidar Stølen *et al* 2024 *J. Phys.: Conf. Ser.* **2885** 012047

View the [article online](#) for updates and enhancements.

You may also like

- [Transitioning to building integration of photovoltaics and greenery \(BIPVGREEN\): case studies up-scaling from cities informal settlements](#)  
Dimitrios Karamanis, Hai-Ying Liu, Nikolaos Skandalos et al.
- [Application of ground-penetrating radar based on U-Net in the statistics on the bonded area of external wall insulation](#)  
J Wang, Y Li, Z Jiang et al.
- [Test protocols and criteria for PV roofs fire behaviour characterization](#)  
Piergiacomo Cancelliere, Giovanni Manzini, Giombattista Traina et al.

# Experimental study of fire propagation on sloped roof with building applied photovoltaics

Reidar Stølen <sup>1,2\*</sup>, Janne Siren Fjærestad <sup>1</sup>, Ragni Fjellgaard Mikalsen <sup>1</sup>,  
Grunde Jomaas <sup>3,4</sup>

<sup>1</sup> RISE Fire Research, Trondheim, Norway

<sup>2</sup> Norwegian University of Science and Technology, Trondheim, Norway

<sup>3</sup> FRISSBE, ZAG, Ljubljana, Slovenia.

<sup>4</sup> FAMNIT, University of Primorska, Koper, Slovenia.

\* reidar.stolen@risefr.no

**Abstract.** Photovoltaic modules have been shown to influence how a fire propagates across a flat roof, but the circumstances for which building attached photovoltaic (BAPV) modules promote fire propagation on a sloped roof is not studied in detail. Therefore, a series of small-medium- and large-scale experiments on a sloped roof with a B<sub>ROOF(t2)</sub>-rated bituminous roof membrane on a wood chipboard substrate has been performed. Steel plates mimicking non-combustible photovoltaic (PV) modules were placed at different distances above the roof. Different sized wood cribs placed in the gap between the roof and the PV module were used as the ignition source. Similarly to findings for flat roofs, the experiments showed that the gap distance and the size of the ignition source are key factors for how far the fire propagates from the starting point. This supports that BAPV installations affect the fire dynamics on roofs. As such, the complete system of roof composition and PV installation needs to be considered as a whole to ensure adequate fire safety levels.

## 1. Introduction

Rooftops represent large areas that are available to produce renewable electric energy through photovoltaic (PV) installations. The PV installations can either be embedded into the roof forming the outer weather cladding of the building as building integrated PV (BIPV), or they can be mounted on top of a complete roof as building attached PV (BAPV) [1]. Fire propagation in the cavity between the roof surface and the BAPV modules has been studied extensively by Kristensen et al. [2–5], Ju et al. [6], and Tang et al. [7]. These studies show that the deflection of the flame below the PV modules increases the heat flux towards the roof surface and the flame spread rate across the roof below the PV modules. The studies found that the distance between the roof and the inclination of the PV module were important parameters to define the increase in heat flux and flame spread rate. With the increased rate of fire propagation and the addition of electric components causing a risk of ignition, the PV installation influences both the probability and consequences of rooftop fires. The earlier studies [2–7] have been focusing on flat roofs with horizontal or tilted PV modules, which is representative for BAPV installations on large industrial buildings. A series of experiments has also been reported by Backstrom et al. on the effect of BAPV modules on sloped roofs where the most severe conditions for fire propagation on the roof were obtained with a 12.7 cm (5 inches) gap distance for an external flame



exposure based on the UL 790 test for roof coverings [8,9]. The novelty in the current study is how fire propagation on sloped roofs is affected by adding BAPV modules when the ignition source is located below the PV modules. These results extend the existing knowledge into the domain of the sloped roofs that are common on many smaller residential buildings.

## 2. Method

Experiments are performed in small-, medium- and large-scales on a roof construction with a 30° slope consisting of a bituminous roofing membrane with a B<sub>ROOF(t2)</sub> rating on a wooden chipboard substrate. The test method (number 2) with burning brands and wind according to CEN/TS 1187 [10] that is used for the B<sub>ROOF(t2)</sub> rating according to EN 13501-5 [11] was used in the small-scale experiments. As the scale of this standardized test setup is small compared to the real roof application with PV installations, the experimental setup was scaled up to a medium and a full scale to allow room for larger ignition sources and a more representative system performance. The effect of the PV modules was mimicked using steel panels as a physical barrier for the flames without contributing with any added combustible material or electrical energy. This would represent an optimal PV module compared to a real PV module that could release heat into the fire from its combustible materials or electric energy released in electrical faults. No significant effects of adding an electrical charge to PV modules during SBI tests were found in an experimental series by Boddaert et al. [12] and minor differences between real PV modules and steel panels were found in experiments by Kristensen et al. [5]. These effects are omitted in the current work to isolate the effect on the roofing membrane. The same materials were used in all the experiments across the different scales, as described in further detail in the following subsections.

### 2.1 Small-scale experiments

The main modification to the experimental setup compared to the standard test described in CEN/TS 1187 [10] was adding a steel plate installed above the roofing surface to mimic a PV module. In Figure 1 (left), the steel plate is shown with a green line above the roof surface and the wood crib. The roof and PV module were instrumented with thermocouples to monitor the spread of heat during the experiments. A total of 19 experiments were carried out with 2 and 4 m/s wind velocity and with 6, 9, 12, and 15 cm gap distance between the roofing surface measuring 400 mm × 1000 mm and the PV module.

### 2.2 Medium-scale experiments

The same materials and roof slope were used in a series of medium-scale experiments where the size of the wood crib was varied to find the initial heat source needed to cause a propagating fire in the cavity between the roof surface and the PV module. The size of the roof surface was 1.2 m × 2.4 m, and a steel plate measuring 1.0 m × 1.7 m was installed 12 cm above the roof surface. The test rig with and without the PV module can be seen in Figure 2 (left).

A total of 6 experiments were conducted with different combinations of the wood cribs listed in Table 1, with and without a steel plate placed above the roof and crib. The wood cribs were ignited and placed on the roof surface 0.3 m above the lower edge of the PV module.

**Table 1.** Specifications of the different wood cribs used in the medium-scale experiments.

<i>Crib name</i>	<i>Stick dimensions</i>	<i>Sticks in each layer</i>	<i>Total mass</i>	<i>Estimated HRR</i>	<i>Standard</i>
1×EN	10×10×100 mm <sup>3</sup>	2+6	40 g	7 kW	CEN/TS 1187 t2 [10]
2×EN	10×10×100 mm <sup>3</sup>	2+6+2+6	80 g	12 kW	CEN/TS 1187 t2 [10]
3×EN	10×10×100 mm <sup>3</sup>	2+6+2+6+2+6	120 g	16 kW	CEN/TS 1187 t2 [10]
UL class B	19×19×150 mm <sup>3</sup>	6+6+6	500 g	9 kW	UL 790 [9]

The estimated free-burning heat release rate (HRR) from each of the wood cribs is calculated based on the method presented by McAllister and Finney [12]. This calculation does not consider the increased re-radiation below the PV module or contributions from the burning of the roofing membrane. It should be noted that the largest UL Class B crib weighing 500 grams did not have the highest HRR, as it is more densely packed than the EN-cribs but burned for a longer time.

### 2.3 Large-scale experiments

Using the UL class B wood crib and gap size of 12 cm, the medium-scale experiments were repeated twice on a large-scale with six steel plates on a roof measuring 4.2 x 5.4 m. A picture of the large-scale experimental setup can be seen in Figure 2 (middle).

## 3. Results

Selected results from the experiments at each scale are presented in the following subsections.

### 3.1 Small-scale experiments

In the small-scale experiments, the flames from the wood crib were following the roof surface. Without any PV modules, as the test is normally performed according to CEN/TS 1182 [10], the length of the damaged roofing membrane was well within the requirement for a  $B_{ROOF}(t_2)$  rating of 55 cm according to EN 13501-5 [11]. Comparable results were found for gap distances of 9 cm and higher, as shown in Figure 3 (left). It can be seen in Figure 1 (lower right) that the flame does not extend all the way up to the steel plate installed 9 cm above the roof. However, for a 6 cm gap, the length of damage increases, and from Figure 1 (upper right) that the flame extends up to the steel plate.

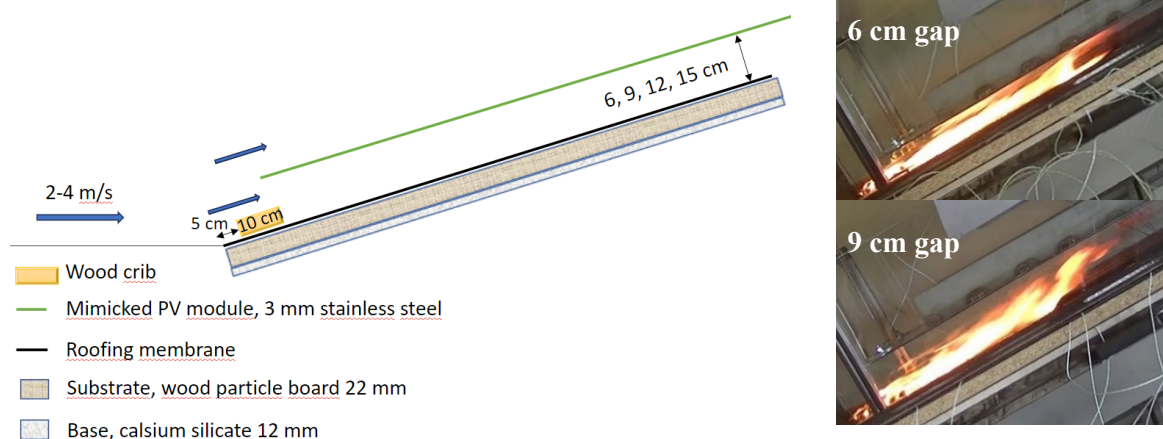

**Figure 1.** Setup for the small-scale experiments, based on test number 2 according to CEN/TS 1187 (left). Small-scale experiments with 2 m/s wind and 6 cm (upper right) and 9 cm (lower right) gap distance. Note the gap between the flame and the steel plate at a 9 cm distance.

### 3.2 Medium-scale experiments

The length of the damaged roof membrane was measured after the experiments. In most of the experiments, the fire self-extinguished when the wood crib burned out, and only localized damage to the roof membrane was observed. The fire propagated all the way up to the top of the roof only in the experiment with the largest UL class B crib and the steel plate. The length of the damaged roof is shown in Figure 3 (right) for the different wood cribs with and without the steel plate.

### 3.3 Large-scale experiments

The fire in the large-scale experiments developed like the medium-scale experiment with the UL class B crib and PV module, where the fire propagated up the roof all the way to the top 1.36 m beyond the top of the steel plates before it self-extinguished. The lateral fire spread was limited to a total width of approximately 2 meters. In one of the experiments, the fire also spread down the roof surface in melted burning bitumen. This fire at the root of the roof was manually extinguished to prevent the fire from spreading in under the roof construction. Figure 2 (right) shows the fire approximately 20 minutes after ignition. The fire did not spread down through the roof construction, and the highest temperature increase below the wooden chipboard was well within the criteria for thermal insulation of mean temperature rise below 140 °C and maximum increase below 180 °C at any single point

according to EN 13501-2 [13]. The total duration of the experiments was approximately 60 minutes until the fires self-extinguished when the roofing membrane was burned up.



**Figure 2.** Medium-scale experiments with a wood crib placed on top of a roofing membrane with a steel plate (left) and without a steel plate (left inserted). Large-scale experiment with steel plates on a roof measuring  $4.2 \times 5.4$  m (middle). Fire propagation in large-scale approximately 20 minutes after ignition where the fire has spread up to the top of the roof (red arrow) and down to the lower edge in the flowing melted bitumen roofing membrane (white arrow) (right).

#### 4. Discussion

The results from the small-, medium- and large-scale experiments show that steel plates installed above the roof, like BAPV modules, can increase the spread of fire across a  $B_{ROOF}(t_2)$ -rated roof. The small-scale experiments show that the length of damage to the roofing membrane was not significantly increased when the distance between the roof and the steel plate was at least 9 cm, but when the distance was as low as 6 cm, the results show an increase in damaged length. With the small wood crib and the wind direction up the roof surface, the flame was already attached to the roof surface without the influence of the PV module. As seen in Figure 1 (lower right), the flame did not reach all the way up to the PV module 9 cm above the roof. This means that the PV module did not deflect the flame at this height and above.

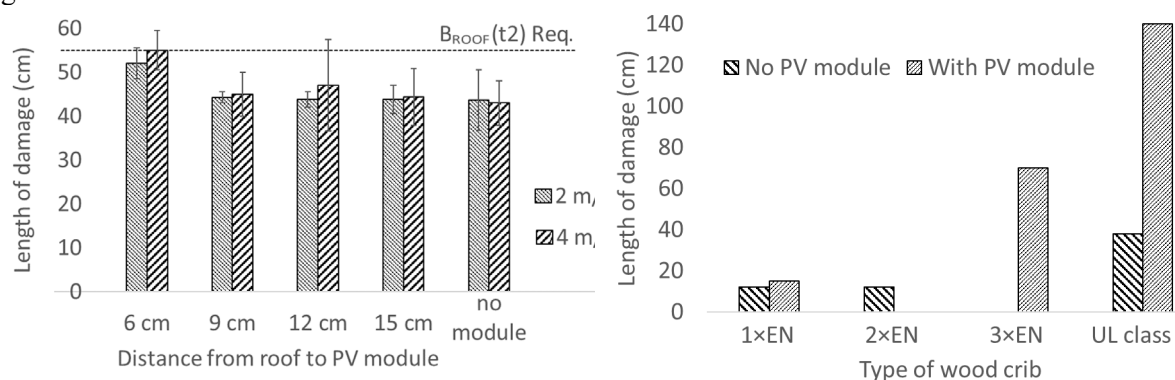

**Figure 3.** The length of the damaged roof membrane in the small-scale experiments with 2 and 4 m/s wind speed (left) and in the medium-scale experiments for the wood cribs are listed in Table 1 (right).

In small scale, a 12 cm gap gave similar damage to the substrate as with no module present. The same, small wood cribs and gap size was investigated in medium scale, the results supporting the findings in small scale, with only a minor increase in the damaged length of the roofing membrane compared with no module. When increasing the fire intensity from a single EN-crib to three stacked EN-cribs, the effect of having a PV module present became clear, with damage length increased, but the

fire was still self-extinguished. With the larger UL class B crib and the steel plate, the ignition source was sufficiently large to start a self-sustained fire that propagated all the way up to the end of the roof before it extinguished. The same crib only caused localized damage to the roof without any PV module. These experiments show that it is not only the gap distance but also the size of the ignition source that decides how the fire can develop on a roof with PV modules. The wood cribs used as ignition sources in these experiments will burn with a rate and duration depending on the crib geometry and ambient conditions. Further studies of the effect of heat release rate and total heat release in the ignition source can be made with a gas burner that allow a more direct and precise control of heat output.

In the large-scale experiments (with a 12 cm gap size and the largest ignition source used), the fire became self-sustained and spread upwards along the roof surface, beyond the top of the modules. A buoyant flame plume was observed spreading rapidly up along the roof below the PV modules, but the gas velocity in this plume was not measured. The limited lateral fire propagation was most likely caused by the buoyant hot gases in the cavity below the PV modules and the entrainment of cold air into the fire plume from the sides and below. The observed fire spread down the roof in melted and burning bitumen could have caused fire propagation further down from the roof or laterally if the burning roofing membrane was collected in a rain gutter and distributed sideways across the lower edge of the roof, potentially representing a fire hazard for evacuation or the fire service's efforts.

Further, the large-scale results indicate that the 22 mm wooden chipboard substrate was sufficient to prevent fire spreading into the attic space of the experimental rig. The chipboard would be expected to burn through in approximately 30 minutes if it were tested according to EN 1363-1 [14,15]. This clearly shows that the fire exposure onto the roof was lower during the experiment than the standard exposure used in fire resistance testing. This can be caused by the relatively short fire duration at each part of the roof, as the combustible material that contributed to it was limited to the roofing membrane. In a case with more available fuel in the cavity, this duration could be increased and cause a more severe fire exposure to the roof construction.

## 5 Conclusions

Experiments in small- medium- and large-scale were done on a sloped roof construction with a bitumen roofing membrane on a wooden chipboard substrate. Steel plates were installed at different distances above the roof to mimic the effect of BAPV modules. Different wood cribs were used to study the fire development in the gap between the roof and the steel plate.

PV modules installed on a roof with a  $B_{\text{ROOF}}(t_2)$  rating can increase the spread of fire when an ignition source is placed below a module. The effect depends on the gap distance between the roof surface and the module and the size of the ignition source. A self-sustained propagating fire can be achieved if the ignition source is sufficiently large. The buoyant plume spreads the fire mostly up the roof surface and to a limited degree laterally. The fire spread was also seen down the roof in the burning melted roof membrane. None of the experiments caused the fire to spread into the roof construction, as the 22 mm wood chipboard proved to have sufficient fire resistance until the roofing membrane was burnt up.

## Acknowledgements

The experimental program was funded by the Norwegian Building Authority (DiBK), the Norwegian Directorate for Civil Protection (DSB) and the Fire Research and Innovation Centre (FRIC). FRIC is funded by the partners and the Research Council of Norway (program BRANNSIKKERHET, project number 294649), including a substantial donation from the Gjensidige Foundation. Results from this study and additional photographs are previously published in a Norwegian RISE report [16]. The FRISBE project (Grunde Jomaas) has received funding from the European Union's Horizon 2020 research and innovation programme under Grant Agreement No. 952395.

## References

- [1] “International definitions of ‘BIPV,’” IEA PVPS, IEA-PVPS T15-04: 2018, Aug. 2018.
- [2] J. S. Kristensen and G. Jomaas, “Experimental study of the fire behaviour on flat roof constructions with multiple photovoltaic (PV) panels,” *Fire Technol.*, vol. 54, no. 6, pp. 1807–1828, 2018.
- [3] J. S. Kristensen, B. Merci, and G. Jomaas, “Fire-induced reradiation underneath photovoltaic arrays on flat roofs,” *Fire Mater.*, vol. 42, no. 3, pp. 316–323, Apr. 2018.
- [4] J. S. Kristensen, F. B. M. Faudzi, and G. Jomaas, “Experimental study of flame spread underneath photovoltaic (PV) modules,” *Fire Saf. J.*, p. 103027, May. 2020.
- [5] J. S. Kristensen, B. Jacobs, and G. Jomaas, “Experimental Study of the Fire Dynamics in a Semi-enclosure Formed by Photovoltaic (PV) Installations on Flat Roof Constructions,” *Fire Technol.*, Mar. 2022.
- [6] X. Ju *et al.*, “Impact of flat roof–integrated solar photovoltaic installation mode on building fire safety,” *Fire Mater.*, 2019.
- [7] F. Tang *et al.*, “Experimental study and analysis of radiation heat fluxes received by a floor beneath an inclined ceiling,” *Fire Mater.*, vol. 45, no. 2, pp. 205–214, Mar. 2021.
- [8] B. Backstrom, M. Tabaddor, and P. Gandhi, “Effect of Rack Mounted Photovoltaic Modules on the Fire Classification Rating of Roofing Assemblies Phase 1,” Underwriters Laboratories Inc., 2009.
- [9] “UL790, Standard Test Methods for Fire Tests of Roof Coverings.” Underwriters Laboratories, 22 Apr. 2004.
- [10] CEN, “CEN/TS 1187:2012 Test methods for external fire exposure to roofs.” European Committee for Standardization, 2012.
- [11] CEN, “EN 13501-5:2016 Fire classification of construction products and building elements – Part 5: Classification using data from external fire exposure to roofs tests.” European Committee for Standardization, Jun. 2016.
- [12] S. Boddaert, F. Parolini, P. Bonomo, and M. Awais, “Most Demanding Standard Combination to Support BIPV Development and Sustainability – Fire Safety,” presented at the WCPEC-8, Milan, Italy, 2022.
- [13] CEN, “EN 13501-2:2023 Fire classification of construction products and building elements - Part 2: Classification using data from fire resistance and/or smoke control tests, excluding ventilation services.” European Committee for Standardization, 2023.
- [14] “EN 1363-1:2020. Fire resistance tests - Part 1: General Requirements,” European Committee of Standardization (CEN), Brussels, Belgium, 2020.
- [15] B. Östman, “Spånskivor,” Trätek; Svenska Träskivor, Stockholm, Märsta, 1992.
- [16] R. Stølen, J. S. Fjærestad, and R. F. Mikalsen, “EBOB – Solcelleinstallasjonar på bygg. Eksperimentell studie av brannspreiing i holrom bak solcellemodular på skrå takflater. Del 2: Teknisk rapport.” RISE Fire Research, RISE Rapport 2022:83, 2022.