

# OPERATION OF BATTERY ENERGY STORAGE SYSTEM FOR FREQUENCY CONTROL OF HYDROPOWER OPERATED IN ISLAND MODE

**AMANDA HALLBLAD**

School of Business, Society and Engineering  
Course: Degree Project in Energy Engineering  
Course code: ERA403  
Credits: 30 hp  
Program: Master of Science in Engineering –  
Energy Systems

*Supervisor:* Pietro Elia Campana  
*Examinor:* Maher Azaza  
*Costumer:* Peter Ekström, SWECO  
*Date:* 2020-06-14  
*Email:* ahd14003@student.mdh.se

## ABSTRACT

The purpose of this study is to analyse how a battery energy storage system (BESS) can support the frequency and voltage stability for an islanded microgrid containing a hydropower plant. Two different microgrids, both situated in Sweden, are evaluated. Modelling and dynamic simulations are conducted in the PowerFactory tool. The result shows that both the frequency and the voltage control can be improved with the BESS. However, with the allowed limit of  $\pm 1$  Hz, not all simulated scenarios including a BESS meets the requirement. A large difference between the BESS and generator capacity might be a possible cause for this. By dividing the larger loads so that smaller loads are attained, the frequency deviation might be reduced. Furthermore, by adjusting the systems PID-parameters according to the island mode operation, faster regulation can be attained. The system operates according to the Master slave control strategy, with the hydropower being the master unit with voltage control and the BESS being a slave unit with PQ control. The ability to operate an islanded microgrid can ensure the supply of electricity to inhabitants and vital functions in society. By utilizing a BESS for increasing electric stability, emission of CO<sub>2</sub> is indirectly mitigated. As cost for BESS are expected to decrease rapidly, they will be accessible for utilization all over the world.

**Keywords:** Battery energy storage system (BESS), hydropower, microgrid (MG), operational strategies, frequency control, PowerFactory

## PREFACE

This master thesis was written during the spring of 2020 as the final part of my Master of Science in Engineering – Energy Systems at Mälardalens University. All the challenges and obstacles have been conquered with the support from some important people that I would like to express my greatest gratitude towards.

Firstly, I would like to thank Magnus Speychal at SWECO who has taken the role as my technical supervisor. Your great expertise and knowledge in the fields of electrical power, energy storage and hydropower has been of substantial importance for finalising this study. Secondly, I would like to express my gratitude to my supervisor at SWECO, Peter Ekström, for offering great support all through the process. I also want to thank Anders Bard at SWECO and Jonatan Fredriksson at ABB for taking your time to extend my knowledge in the field of hydropower.

Lastly, I would like to thank my supervisor at Mälardalens University, Dr Pietro Elia Campana. You have provided valuable support and feedback for conducting the report and the continuity of the process.

Västerås, June 2020

*Amanda Hallblad*

## SUMMARY

Electricity is a part of our everyday life and it powers essential functions in society. Without electricity, access to freshwater would be affected, as well as the possibility to withdraw money from the bank. A major event in the national grid could jeopardize the accessibility to electricity and these functions. Even though it is unusual with such events, self-sufficiency can provide stability and security when it is needed the most. Formation of an islanded microgrid is achieved by disconnecting the local electricity network from the national grid. The national grid offers stability of frequency and voltage, consequently setting higher requirements on control of frequency if a microgrid was to operate completely isolated from the national grid. A mismatch between electricity production and electricity demand causes deviation of frequency. The setpoint for the frequency is 50 Hz and the deviation should not exceed  $\pm 1$  Hz. BESS can provide stability in a microgrid by offering assistance of frequency control. The aim of this study is to evaluate how a battery energy storage system can be utilized in a microgrid operated in island mode in combination with a hydropower plant. The two systems analyzed are located in Sweden, Ludvika and Ålem. The power plant in Ludvika is prepared for microgrid operation, whereas the power plant in Ålem is not. Therefore, two different scenarios were tested for the Ålem case, frequency control by means of wicket gate, and frequency control by means of runner blade. The Ludvika plant contains frequency control by means of wicket gate. To evaluate the performance of the BESS, all scenarios were tested with and without BESS connected. The model was built in the PowerFactory software and dynamic simulations were conducted to see the performance at load changes.

Due to problems with the initial conditions for the models at low load, base loads were added. By including these, the total power demand was increased. At low load, a suitable fit for the combination curve that is used as input to the model could not be found. The result shows that with assistance from the battery energy storage system the deviation in frequency can be reduced. With the limitation of  $\pm 1$  Hz, both Ålem cases that include the BESS are within the acceptable range. However, the Ludvika case exceeds the given range. The reason for this might be that the connection of loads is too large. By decreasing the loads or dividing them, it will be possible to obtain a frequency deviation lower than  $\pm 1$  Hz. The voltage was in no risk of being outside of the given limit at  $\pm 10\%$ . However, the result showed that the peak in voltage deviation could be reduced by the BESS, improving the stability of the system. The voltage control is executed by the hydropower as it is set as the reference machine. PQ control is taken on by the BESS, controlling the reactive and active power in response to frequency and voltage deviations by means of droop control.

# CONTENT

- 1. INTRODUCTION .....1**
  - 1.1. Background ..... 1**
    - 1.1.1. *Electricity network monitoring*..... 1
    - 1.1.2. *The electricity networks*..... 2
    - 1.1.3. *Microgrid operated in island mode* ..... 2
      - 1.1.3.1. *Frequency and voltage*.....3
      - 1.1.3.2. *Inertia*.....3
      - 1.1.3.3. *Battery energy storage system (bess)*.....3
      - 1.1.3.4. *Economy*.....4
    - 1.1.4. *Previous studies*..... 4
    - 1.1.5. *Problem description* ..... 4
  - 1.2. Purpose..... 5**
  - 1.3. Research questions ..... 5**
  - 1.4. Delimitation..... 5**
- 2. METHOD .....7**
  - 2.1. Choosing of topic ..... 7**
  - 2.2. Literature review..... 7**
  - 2.3. Data collection ..... 7**
  - 2.4. PowerFactory software simulation..... 8**
- 3. THEORETICAL FRAMEWORK.....8**
  - 3.1. BESS operation ..... 9**
  - 3.2. Control methods..... 9**
    - 3.2.1. *PQ control*..... 9
    - 3.2.2. *V/f control*..... 9
    - 3.2.3. *Droop control* .....10
  - 3.3. Control Strategies .....10**
    - 3.3.1. *Master-slave* .....10
    - 3.3.2. *Hierarchy control*.....11

<b>3.4. Hydropower – Kaplan turbine</b> .....	<b>11</b>
<b>3.5. PID controller</b> .....	<b>12</b>
<b>3.6. Case studies</b> .....	<b>13</b>
3.6.1. <i>Hydropower</i> .....	13
3.6.2. <i>BESS control strategies</i> .....	13
<b>4. CURRENT STUDY</b> .....	<b>14</b>
<b>4.1. Ludvika</b> .....	<b>14</b>
4.1.1. <i>Microgrid formation</i> .....	14
4.1.2. <i>Simulation</i> .....	14
4.1.3. <i>Ludvika electricity network</i> .....	15
4.1.4. <i>Ludvika data</i> .....	17
4.1.5. <i>Curve fitting</i> .....	18
<b>4.2. Ålem</b> .....	<b>21</b>
4.2.1 <i>Microgrid formation</i> .....	21
4.2.2 <i>Simulation</i> .....	21
4.2.3 <i>Ålem electricity network</i> .....	21
4.2.4 <i>Ålem data</i> .....	23
4.2.5 <i>Curve fitting</i> .....	23
<b>4.3. The BESS</b> .....	<b>24</b>
<b>4.4. Verification of the model</b> .....	<b>25</b>
<b>5 RESULTS</b> .....	<b>26</b>
<b>5.1 Ålem</b> .....	<b>26</b>
5.1.1. <i>Wicket gate simulation</i> .....	27
5.1.2 <i>Runner simulation</i> .....	30
5.1.3. <i>All scenarios</i> .....	33
<b>5.2. Ludvika</b> .....	<b>34</b>
<b>5.3. Disconnection of loads</b> .....	<b>38</b>
<b>6 DISCUSSION</b> .....	<b>39</b>
<b>6.1. Model construction</b> .....	<b>39</b>
<b>6.2. Simulation and result</b> .....	<b>40</b>

6.3. Control strategy.....	41
6.4. Social and economic aspects.....	42
7 CONCLUSIONS .....	42
8 SUGGESTIONS FOR FURTHER WORK .....	43
REFERENCES.....	44

**APPENDIX A: MODEL**

**APPENDIX B: PID-PARAMETERS**

**APPENDIX C: GENERATOR DATA**

**APPENDIX D: RESULT – DISCONNECTION OF LOADS**

# LIST OF FIGURES

- Figure 1 Frequency mapping (SVK, 2020)..... 2
- Figure 2 Hydropower illustration (Engineers, 2011) .....12
- Figure 3 PID-controller illustration (Urquizo, 2011) .....12
- Figure 4 Line diagram in PowerFactory of Ludvika electricity network .....16
- Figure 5 Curvefitting efficiency Ludvika ..... 18
- Figure 6 Curvefitting mass flow Ludvika .....19
- Figure 7 Combination curve..... 20
- Figure 8 Line diagram in PowerFactory of Ålem electricity network..... 22
- Figure 9 Verification of model ..... 25
- Figure 10 Verification of model zoomed ..... 26
- Figure 11 Ålem – Wicket gate; Frequency..... 27
- Figure 12 Ålem – Wicket gate; Voltage .....28
- Figure 13 Ålem - Wicket gate; Regulation of runner blade and wicket gate..... 29
- Figure 14 Ålem - Wicket gate; BESS power ..... 30
- Figure 15 Ålem - Runner blade; Frequency .....31
- Figure 16 Ålem - Runner blade; Voltage .....31
- Figure 17 Ålem - Runner blade; Regulation..... 32
- Figure 18 Ålem - Runner blade; BESS power ..... 33
- Figure 19 Ålem; all scenarios ..... 34
- Figure 20 Ludvika; Frequency ..... 35
- Figure 21 Ludvika; Voltage..... 36
- Figure 22 Ludvika; Regulation of runner blade and wicket gate..... 37
- Figure 23 Ludvika; BESS power..... 38

# LIST OF TABLES

- Table 1 Ludvika max loads .....17
- Table 2 Ludvika generator data .....17
- Table 3 Ludvika turbine data ..... 18
- Table 4 Coefficients efficiency curve ..... 18
- Table 5 Goodness of fit .....19
- Table 6 Coefficients curve fitting mass flow .....19
- Table 7 Goodness of fit ..... 20
- Table 8 Coefficients curve fitting combination curve ..... 20
- Table 9 Goodness of fit combination curve..... 20
- Table 10 Ålem max loads..... 23
- Table 11 Ålem generator data ..... 23
- Table 12 Ålem turbine data ..... 23

Table 13 Coefficients curve fitting efficiency.....	24
Table 14 Coefficients curve fitting mass flow.....	24
Table 15 BESS parameters .....	24

## NOMENCLATURE

Description	Unit
Active power	W
Frequency/ f	Hz
Frequency droop/ fdroop	% , p.u.
Per unit	p.u.
Reactive power	kVA
Runner blade regulation speed	°/s , %/s
Voltage	V
Wicket gate regulation speed	mm/s , %/s

## ABBREVIATIONS

Abbreviation	Description
<b>BESS</b>	Battery Energy Storage System
<b>CO<sub>2</sub></b>	Carbon dioxide
<b>DG</b>	Distributed generators
<b>ESS</b>	Energy storage system
<b>LCOS</b>	Levelized cost of storage
<b>LV</b>	Low Voltage
<b>MG</b>	Microgrid
<b>PID</b>	Proportional-integral-derivative
<b>PV</b>	Photovoltaic
<b>RES</b>	Renewable energy sources
<b>SVK</b>	Svenska kraftnät (The Swedish electricity authority)
<b>UPS</b>	Uninterrupted power supply

## DEFINITIONS

<b>Definition</b>	<b>Description</b>
<b>Ålem Energi</b>	The distribution system operator in Mönsterås that owns the hydropower plant and the electrical grid
<b>High Voltage Valley</b>	A part of the Ludvika-Smedjebacken development company Samarkand2015
<b>Hydropower</b>	Generates electricity as water passes through a turbine which drives a generator
<b>Island mode</b>	A microgrid operated disconnected from the national grid
<b>Microgrid</b>	A small electricity grid that is operated in island mode
<b>National grid</b>	The main electricity network that provides electricity to the nation.
<b>PID-controller</b>	Governor of frequency and regulation variables
<b>PowerFactory</b>	The simulation software used for modelling of the power systems
<b>Runner blade</b>	Regulates the flow of water passing through the turbine
<b>VB Energi</b>	The energy company in Ludvika that owns the electrical grid
<b>VB Kraft</b>	The distribution system operator in Ludvika that owns the hydropower plant
<b>Wicket gate</b>	Regulates the inlet flow of water to the turbine

# 1. INTRODUCTION

Swedish society today is highly dependent on electricity. An extensive power outage would consequently be a massive challenge and disrupt essential functions. The access to freshwater would be significantly affected as the water supply and distribution systems would not work, as well as the sewer system. The tele- and network connection would be down, leading to mobile phones and computers being unusable and making it impossible to withdraw money from the bank. Not to mention the economic consequences it can have on energy-intensive industries. Even though greater power outages in Sweden is uncommon, the Swedish electricity network is sensitive to unexpected disruptions. In the year 2005, Sweden experienced a massive power outage with 730 000 household due to the storm Gudrun. A large number of households lacked electricity for more than 20 days. (MSB, 2019b) Since then a new Swedish law has been established, demanding that the network operators must provide electricity within 24 hours after a power outage. The law also includes a demand for the operators to prohibit risks that causes a power outage. (MSB, 2019a) Harsh weather is likely to cause power outages due to damages on the power lines, which can be caused by thunder, a large amount of falling snow or strong winds with trees or branches falling on the power lines. Technical failure and power shortage are other reasons for a power outage. A power shortage occurs when balance between produced electricity and electricity demand is erupt. There is usually an overproduction of electricity in Sweden and that electricity is transmitted to nearby countries, keeping the balance intact. However, there are some areas in Sweden which have power shortages, Stockholm and Malmö being two of them (Zachariasson, 2019).

This study evaluates possible improvements for electric network stability, that consequently can secure the distribution of electricity.

## 1.1. Background

This section begins with brief introductions for some of the most important components for this study, followed by a summary of previous studies which are related to this study. Lastly, the problem description is presented.

### 1.1.1. *Electricity network monitoring*

The Swedish electricity authority SVK (Svenska kraftnät) is responsible for ensuring the short-term balance in the electricity network (SVK, 2019). Sweden's frequency is set to 50 Hz, when the production is higher than the demand, the frequency will increase, and it will decrease when the demand is higher than the production. This is controlled both automatically and manually by SVK. The frequency should not exceed 50,1 Hz and not fall

below 49,9 Hz. (SVK, 2020) Figure 1 is collected from SVK and their “control room” where operation data is presented in real-time.

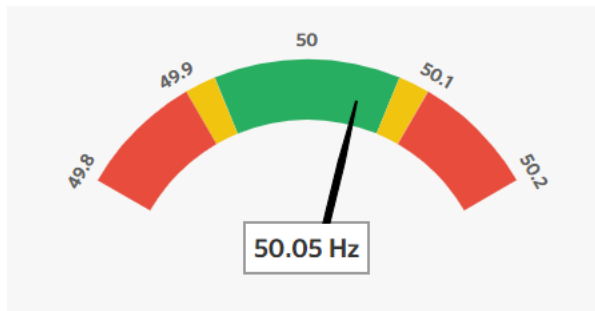

*Figure 1 Frequency mapping (SVK, 2020)*

A power reserve is constructed each year to provide electricity when the generation and import of power are not enough (SVK, 2019). If a shortage of power would occur despite this, SVK has the authority to manually disconnect some parts of the network from the national grid in the aims of providing electricity to the most vital parts in the country (Energimyndigheten, 2020). This would result in some households or villages having no electricity.

The municipalities are responsible for providing the residents with fresh water and access to a warm place if there is cold weather. It can be attained with backup power for important facilities such as town halls, information facilities and elderly care. (MSB, 2019a)

### **1.1.2. The electricity networks**

The Swedish electricity network is highly centralised, mostly powered by electricity generated from hydropower and nuclear power (Forum för smarta elnät, n.d.). Between the producers and the end-users, the electricity is transferred by the electricity network. It can be divided into two categories, the transmission network and the distribution network. The distribution network is both the regional and the local network. The main power line is the transmission network, which has a voltage of 220-400 kV, the high voltage leads to the electricity being transferred with low losses. It is controlled by SVK. The regional network transfers the electricity from the transmission line to the cities with a voltage between 20 and 130 kV. Production facilities and larger industries are often connected to the regional power line. At last, the local network, also called the low voltage (LV) network, distributes the electricity to the consumers and the power line has a voltage of 0,4-20 kV. (Nordling, 2016)

### **1.1.3. Microgrid operated in island mode**

The desire to attain a flexible electricity network with a high penetration of renewable energy sources (RES) promotes the development of microgrids (MG) and decentralised electricity generation (Gao, 2015). There is no exact definition of a MG, but in general, it consists of four main parts, distributed generators (DG), energy storage systems (ESS), load clusters and an electricity network, often low voltage. A MG normally operates connected to the national grid, but the distinctive feature with a MG is that it can be disconnected from the national

grid and operate in island mode. It can also operate completely isolated, which can be useful in remote locations far away from the electricity network. (Gao, 2015; Olivares et al., 2014; Tesarova & Nohac, 2014) The installed capacity varies from a few hundred kilowatts to a couple of megawatts, meaning that it can provide electricity for a single-family residential building or for a small village (Ganji & Shahidehpour, 2018). DG systems typically include technologies such as solar power, wind power and hydropower which generates renewable energy (Gao, 2015; Olivares et al., 2014; Tesarova & Nohac, 2014). ESS provides storage of the generated electricity as well as stability, and can include technologies such as batteries and flywheels (Aghamohammadi & Abdolahinia, 2014; Breeze, 2018; Gao, 2015).

#### 1.1.3.1. *Frequency and voltage*

In grid-connected mode, frequency and voltage for the MG are maintained within the given range thanks to the national grid (Aghamohammadi & Abdolahinia, 2014; Olivares et al., 2014). The national grid offers support, which consequently results in some challenges for a MG operated in island mode (Gao, 2015). Unbalance between the power supply and demand causes variations in frequency and voltage (Aghamohammadi & Abdolahinia, 2014; Tesarova & Nohac, 2014), especially due to low inertia. Without proper control strategies, a severe deviation in frequency can lead to a blackout. (Aghamohammadi & Abdolahinia, 2014; Cagnano, De Tuglie, & Mancarella, 2020)

#### 1.1.3.2. *Inertia*

An electricity network consisting of hydropower and nuclear power contains large inertia due to the synchronous generators (Olivares et al., 2014). MGs usually have low inertia, which is consistent with the large number of RES used in MGs (Hajiakbari Fini & Hamedani Golshan, 2018; Samanta, Mishra, & Roy, 2019). RES such as PV panels and wind generator with interfacing power electronics lack synchronous generators which holds kinetic energy (Hajiakbari Fini & Hamedani Golshan, 2018). For a MG operated in island mode, low inertia can cause deviation in frequency. (Cagnano et al., 2020; Olivares et al., 2014)

#### 1.1.3.3. *Battery energy storage system (BESS)*

ESS are essential components in a MG, they can be utilised for various applications and operation strategies (Khodadoost Arani, B. Gharehpetian, & Abedi, 2019; Olivares et al., 2014). For instance, in the transmission network by providing capability improvements, increasing power quality, ancillary services, vehicle to grid applications or for operation in island mode (Gao, 2015). ESS can decrease losses and increase reliability for a MG (Gao, 2015; Olivares et al., 2014). Battery energy storage systems (BESS) offer the advantage of fast control of frequency and virtual inertia (Gao, 2015).

#### 1.1.3.4. *Economy*

According to Ciez and Steingart (2020) the rapid reduction of cost for lithium-ion batteries have enabled their utilization in electricity grid storage application. However, in order to enable low-cost energy storage technologies globally, the cost needs to be reduced further. The cost forecast for BESS are evaluated by Cole and Fraizer (2019). Their study shows that the capital cost will decrease. By 2030, cost will be reduced by maximum 67% and minimum 21% and by 2050, cost will be reduced with up to 80% and minimum 31%. Another study by Schmith, Melchinor, Hawkes and Staffell (2019) evaluates the projections of levelized cost of storage (LCOS) for several different storage technologies. The result shows that the lifetime cost is expected to fall with 36% by 2030 and 53% by 2050. This is a cost for several technologies and the lithium-ion batteries is expected to have the most rapid cost reduction.

#### 1.1.4. *Previous studies*

Three previous studies have been conducted at SWECO, which are all related to this study. The first study, *Adapting small hydropower plants for frequency control of power grids in island mode* was written by Jonathan Fredriksson (2019). The study evaluates applications for frequency control of the Ålem network in island mode. Fredriksson built a model of the hydropower plant in MATLAB Simulink which is utilized as a reference model for this study. Furthermore, some relevant input data is attained from the study.

The second study is written by Göran Forsling and Aisan Rasouli (2017) and evaluates the prioritised loads in the islanded Ludvika microgrid. Simulation of load connections are conducted, thus evaluating the frequency and voltage stability. This system does however not include the BESS and a representative model of the hydropower plant. Size of loads and limits for frequency and voltage deviation is attained from this report. Accordingly, the maximum allowed frequency deviation is  $\pm 1$  Hz and the maximum allowed voltage deviation is  $\pm 10\%$ . There are two groups of loads. The prioritised loads are the loads that are seen as critical for town operation. The second group of loads are hypothetical. This means that neither the loads nor the cable data are represented by real numbers.

Lastly, frequency and voltage stability is assessed in the study written by Magnus Speychal (2019). The system concerned is the microgrid in Ludvika in island mode. The main purpose of the report is to analyse the connection of prioritised loads as the BESS provides power for six hours. This is before the hydropower plant is up and running.

#### 1.1.5. *Problem description*

The demand for electricity is not expected to decrease in the nearby future. With the transport section switching from fossil-based fuel to electricity and as digitalisation keeps spreading to all functions in society, the demand for electricity becomes more prominent. Increasing uncertainties around the world today causes an elevated fear of terrorist attacks. Vital functions in society are especially vulnerable for attacks and such an attack could cause

great harm. Electricity production being one function that is sensitive to cyberattacks and vandalization. An unforeseen event in the electricity network could affect the whole of the Swedish national grid. (MSB, 2019b) Operation in island mode, disconnected from the national grid, offers the possibilities to be self-sufficient and provide electricity to the most vital functions in society regardless of any disturbances in the national grid. Network operators and municipalities both have certain responsibilities to ensure the distribution of electricity to customers, which can be provided via backup power (MSB, 2019a). Common backup power is the diesel generator. The awareness for greenhouse gas emission and contribution to global warming results in a desire to change from diesel generators to more environmentally friendly options, such as BESS for example (Hajiakbari Fini & Hamedani Golshan, 2018).

A MG operated in island mode is sensitive for disturbances (Olivares et al., 2014). The power production needs to be equal to the power demand. A variance could result in a deviation in frequency or voltage, which consequently could cause a power outage. (Aghamohammadi & Abdolahinia, 2014) A BESS can provide support for a MG operated in island mode. (Hajiakbari Fini & Hamedani Golshan, 2018)

## **1.2. Purpose**

In an unforeseen event of a severe power outage, two different areas in Sweden plan to disconnect their network from the national grid. Two different existing MG networks will be evaluated in this thesis: VB Energi in Ludvika and Ålem Energi in Mönsterås, both situated in Sweden. Hydropower stations will provide electricity to the most vital parts of society and operate in island mode. The purpose with this study is to evaluate how a battery energy storage system (BESS) can be utilized in these systems. How it can support the operation of the hydropower, enable faster regulation, and provide stability for the frequency and the voltage.

## **1.3. Research questions**

- How should the BESS be operated in order to attain a stable grid with frequency and voltage within given boundaries?
- What advantages will the BESS provide for the microgrid?
- How will it affect the overall performance of the system?

## **1.4. Delimitation**

This thesis will evaluate how a battery storage system can be utilized in combination with a hydropower plant operated in island mode. The main focus is to evaluate the performance of the battery storage system rather than the performance of the hydropower plant. Two

existing hydropower plants are considered, one located in Ludvika and one located in Mönsterås. Both energy companies have the aim to be able to disconnect from the national grid when needed and to operate in island mode. This study will only consider these cases, that is, two different MG operated in island mode. As previous studies have been constructed before the start-up of the hydropower plant in island mode, this study will only consider the operation of the MG after start-up.

## 2. METHOD

To answer the research questions, the study is based on the following methodology steps:

- Literature review
- Data collection
- Model construction and simulation
- Analysis of the result

### 2.1. Choosing of topic

This thesis is commissioned by SWECO in collaboration with their costumers, High Voltage Valley and Ålem Energi. The main task assigned by SWECO is to evaluate how a BESS can be operated in combination with a hydropower plant operated in island mode. When addressing the subject, it is of importance that the topic is suitable within the *Master of Science programme in Engineering – Energy Systems* as it is where the thesis is conducted. It should also provide the possibility to fulfil the course requirements for the course *Degree Project in Energy Engineering*. Lastly, the thesis should provide value for the customer SWECO and their clients. The topic is highly relevant as the thrive for self-sufficiency is a hot topic as well as MGs operated with BESS. In order to completely fulfil the course requirements, a literature review and an economic evaluation are added to the study.

### 2.2. Literature review

The main focus of the literature review was to find control methods and strategies for BESS operated in an islanded MG. This also included attaining deeper knowledge on the operation of BESS. The studies economic evaluation is based on literature research, focusing on analyses of future price development of BESS and batteries. Literature has been collected from relevant search engines, mainly from *Science Direct*. Search terms that have been used in different constellations are *operation strategy, island mode, BESS, microgrid, hydropower*.

### 2.3. Data collection

As this thesis is a case study of two existing hydropower plants, data for the turbines, generators, the electric grids and the loads are associated with these. There are three different corporations involved in Ludvika. High Voltage Valley being the customer and owner of the BESS, technical data about the BESS is provided by them. VB Elnät provides the data for the electrical grid and the power demand as they are the owners of the electrical grid. VB kraft owns the hydropower plant and therefore provides technical data for the generator and the turbine.

In Ålem, there is only one corporation involved as Ålem Energi is the owner of both the hydropower plant and the electrical grid. Most technical data and operation data are attained from a previous study executed by SWECO regarding the operation of the hydropower plant operated in island mode. Data which is not included in that report is attained from Ålem Energi. TURAB delivered the generator to Ålem, thus, the generator data is provided by them.

## **2.4. PowerFactory software simulation**

The operation of the electric network with the hydropower and the battery is simulated and modelled in the PowerFactory software. The PowerFactory tool is built by the German software and consulting company DIgSILENT GmbH. They provide services in the field of electrical power systems for transmission, distribution, generation, industrial plants and renewable energy (DIgSILENT, n.d.-a). The PowerFactory software is useful for analysing generation, transmission, distribution and industrial systems. (DIgSILENT, n.d.-b)

The PowerFactory software is a crucial tool for the project to attain an operation strategy for the battery. Therefore, modelling and understanding of the software has been highly prioritised. The PowerFactory software is a well-acquainted tool at SWECO, therefore they have provided the needed support.

As the PowerFactory simulation tool is a well-known software it is highly applicable for this study as it allows for both static and dynamic simulations. The microgrids are modelled in PowerFactory and contain the electrical grid, hydropower plant and the BESS. A complete model of the BESS utilised in Ludvika is provided by ABB and it is included in both models. A finished model by the manufacturer ensures a viable model. The model of the hydropower plant in PowerFactory is based on an existing MATLAB Simulink model which was constructed by a previous study by SWECO for Ålem Energi. In order to ensure the feasibility of the hydropower plant model, it is verified according to the reference model. After the simulations, diagrams showing the dynamic behaviour for frequency, voltage and power from the BESS are attained and analysed.

## **3. THEORETICAL FRAMEWORK**

The theoretical framework for this study aims to give a better understanding of different control methods and strategies, which can be of help in deciding the operation strategy for the BESS. Therefore, three different control methods are presented as well as two different control strategies. The control methods give an idea of what methods can be utilized for achieving steady-state operation with stable frequency and voltage. Whereas the control strategies describe how these control methods can be combined in the operation of the MG. The control strategies and control methods are followed by sections describing technical

aspects as well as operational strategies for hydropower and BESS operated in an isolated MG.

### **3.1. BESS operation**

If a deviation of frequency occurs, the frequency needs to either be increased or decreased so it reaches 50 Hz. How this can be performed by a BESS, is described by Gao (2015). A battery is connected to an inverter, that transforms emulated kinetic energy into electromagnetic power in order to deliver real power to the MG. Depending on the frequency, the BESS either absorbs or releases active power by emulating the inertial response of a conventional generator. In relation to conventional generators, BESS can have improved frequency recovery response time. When kinetic energy is extracted from the rotating mass of turbine and generators, the rotor speed is reduced, which consequently needs to be restored. As BESS have synthetical inertia, the response time is much faster compared to the one for conventional generators.

### **3.2. Control methods**

BESS can be utilized for voltage and frequency control for MG in islanded mode (Khodadoost Arani et al., 2019). There are different kinds of control methods for operation of a microgrid (Gao, 2015). The three main types of methods are PQ control, V/f control and droop control (Gao, 2015; Khodadoost Arani et al., 2019).

#### **3.2.1. PQ control**

The PQ control method is to keep the reactive and active power constant. The active and reactive power are decoupled with the aims to achieve independent control. The active power controller should maintain the active power constant within a given frequency range. The reactive power controller should maintain the reactive power output constant within a given voltage range. The PQ controller cannot maintain the frequency and voltage constant and therefore needs control strategies. (Gao, 2015) The PQ control method is often applied in grid-connected microgrids for control of ESS (Khodadoost Arani et al., 2019).

#### **3.2.2. V/f control**

V/f control aims to maintain the frequency and voltage constant regardless of the active and reactive power output. The frequency is maintained within a given range by the frequency controller, which adjusts the active power output. The voltage is maintained within a given range by the voltage controller, which adjusts the reactive power output. (Gao, 2015) V/f controller is typical to utilize in a microgrid operated in island mode. (Gao, 2015; Khodadoost Arani et al., 2019)

### **3.2.3. Droop control**

The droop control method is based on the fact that the change in frequency and voltage is linear to the change in active and reactive power, respectively (Gao, 2015; Khodadoost Arani et al., 2019). It represents how a synchronous generator work. It stabilizes the MG under load changes and is suitable for control of micro sources. It is typical to use droop control as a control for the cooperation of different ESS. (Khodadoost Arani et al., 2019)

## **3.3. Control Strategies**

Here, two different control strategies are presented, the master slave control and the hierarchy control.

### **3.3.1. Master-slave**

When a microgrid is operated in island mode, the DG or the ESS will control the frequency and voltage by applying V/f control (Cagnano et al., 2020). It sets a reference for the frequency and voltage for the other DGs and ESS operated in the microgrid. Other DGs are in control by the PQ. The V/f controller is called the master controller while the others are called the slave controllers. The actions conducted by the slave controllers are dependent on the data from the master controller. (Gao, 2015) When the microgrid operates in grid-connected mode, there is no need for control of the frequency and voltage as this is provided by the national grid (Aghamohammadi & Abdolahinia, 2014). Therefore, all the controllers in the microgrid are set to PQ control mode (Gao, 2015).

There are three commonly used master units, an ESS, a DG or an ESS integrated with DG (Cagnano et al., 2020). The problem with using ESS as master controller is that it discharges and will eventually run out of power (Gao, 2015). Consequently, it cannot operate in island mode for very long. A DG like a micro turbine is more suitable for operation as master controller and can easily regulate the frequency and voltage (Cagnano et al., 2020). The last option is to use an ESS in combination with DG as master controller. This is a good option for renewable energy sources, such as PV and wind power as it can help reduce deviation in voltage and frequency. (Gao, 2015)

An ESS that has large capacity can act as a master unit and thereby regulate the power output and bring the frequency and voltage back to the reference values (Gao, 2015). It offers support for frequency and voltage. The other DGs operates as slave units and regulates the PQ mode. The ESS mitigate the dynamic mismatches between the load and the generated power. (Olivares et al., 2014)

According to Gao (2015), application of a master-slave unit requires many communication channels, which causes a high investment cost. It can be difficult to implement the master slave control method for larger microgrids. The master-slave method sets big requirements on communication and supervisory control.

### **3.3.2. Hierarchy control**

The hierarchy control method has a central controller that sends signals to the included components in the MG, DGs, ESS and loads (Gao, 2015). The control is operated in three steps, the 1-primary, 2-secondary and the 3-tertiary control (Khodadoost Arani et al., 2019). The first step controls the voltage, frequency and load change to keep the frequency and voltage within a stable range (Gao, 2015; Khodadoost Arani et al., 2019). The primary control has the fastest response of all control levels (Khodadoost Arani et al., 2019; Olivares et al., 2014). After the primary control, a mismatch between the steady state frequency and voltage might occur, consequently influencing the active and reactive power (Khodadoost Arani et al., 2019). This is restored by the secondary control (Olivares et al., 2014). The last control level, the tertiary control, relates to economical or market issues (Khodadoost Arani et al., 2019).

### **3.4. Hydropower – Kaplan turbine**

The active power output from the hydropower depends on the angle of the wicket gate and the runner blades. The wickets gate are adjusted to regulate the flow of water reaching the turbine. (Vahidi, Jazebi, & Naghizadeh, 2012) The runner blade opening is adjusted to meet the power demand (Bergström & Ayaad, 2011). An optimal combination between the wicket gate and the runner blades gives the best efficiency. This means that the angle of the runner blade is dependent on the angle of the wicket gates. The attained curve is called the combination curve. (Gustafsson, 2013) A Kaplan turbine can be operated in three different ways, either by both adjustable wicket gates and runner blades or one of them in fixed position (Bergström & Ayaad, 2011). According to (British Electricity International, 1991) adjustable wicket gates and runner blades gives the highest efficiency. The efficiency is slightly reduced if the wicket gate is fixed, whereas the lowest efficiency is attained when the runner blade is in fixed position.

Frequency can be controlled by regulating the wicket gate and runner blade opening. It is typical that the wicket gates have faster dynamic response compared to the regulation of runner blade, however, regulation of runner blades have larger effect on the power output. This effects the system when it operates in island mode. As the wicket gate opening regulates according to change in load, steady state is not reached before the runner blades are adjusted. Depending on how fast the regulation is, an oscillation in frequency can occur. Control of the frequency and power generation is often governed by a PID-controller. (Gustafsson, 2013)

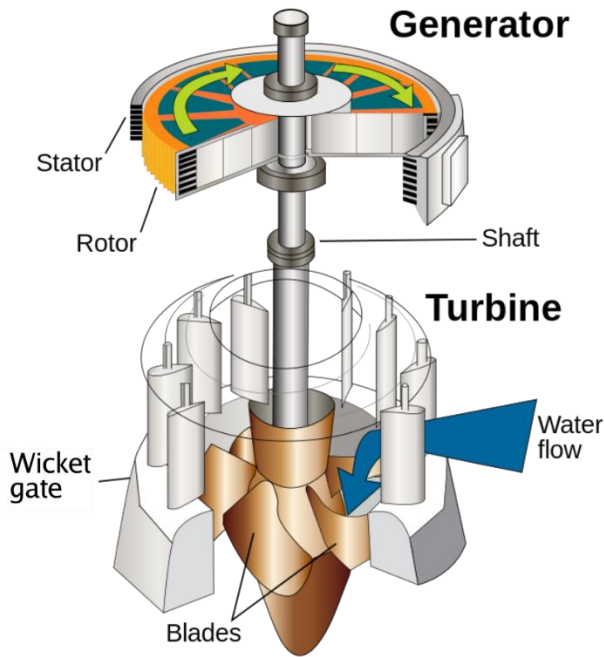

Figure 2 Hydropower illustration (Engineers, 2011)

### 3.5. PID controller

A PID-controller can be used for industrial applications and PID denotes the full name which is proportional-integral-derivative controller. Figure 3 illustrates the basic concept of a PID-controller, it operates in a loop to reduce the error ( $e(t)$ ), which is the difference between the desired setpoint and the measured value from the process. The  $K_P$  value can reduce the rise time,  $K_D$  is applied to reduce the overshoot and settling time and  $K_i$  eliminates the steady state error. (Vahidi et al., 2012)

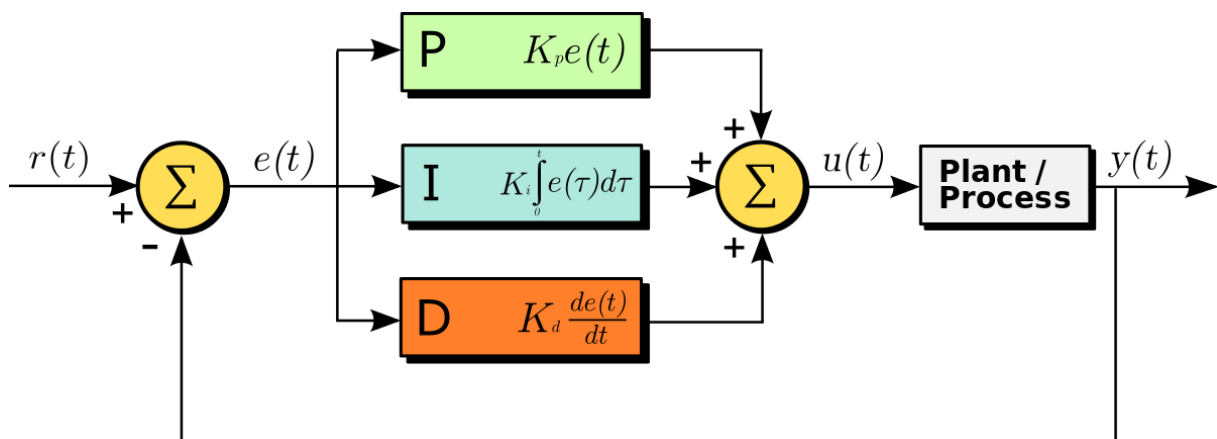

Figure 3 PID-controller illustration (Urquiza, 2011)

### **3.6. Case studies**

Due to the difficulty of finding studies containing the same operation scenario as this study, supporting the operation of hydropower with a BESS operated isolated from the national grid, similar studies are analysed.

The first case study presented is a part of the book *Renewable Energy Integration: Practical Management of Variability, Uncertainty, and Flexibility in Power Grids* written by Jones (2014). It involves micro hydropower operated in isolated mode.

The second case study is *A new approach for optimal sizing of battery energy storage system for primary frequency control of islanded Microgrid*, which is an article written by Aghamohammadi and Abdolahinia (2014). This study includes operational strategies for a BESS working as the primary frequency control of a MG.

#### **3.6.1. Hydropower**

Operation of an islanded MG with micro hydropower is considered by Jones (2014). The system has a 7,5 MW peak load and includes two 6,6 MVA hydro generators, powered by horizontally mounted Francis turbines. Several different operation scenarios are evaluated, including three different loads, ranging between light at 3.1 MW, medium at 6.2 MW and heavy at 9.3 MW and three different generations with high being 9 MW, intermediate at 6 MW and low at 3 MW. The main objective was to evaluate these different operation scenarios with operation in island mode and attain frequency and voltage within a given range. The conclusion is that all operation scenarios are successful with exception from the three with the heavy load. They need additional action to reach steady-state voltage control. Actions that can be applied is capacitor switching or increase the reference for the mini hydro voltage.

#### **3.6.2. BESS control strategies**

In the article by Aghamohammadi and Abdolahinia (2014) the MG includes 79 kW installed capacity from a diesel generator, microturbine, a solid oxide fuel cell, PV and a BESS. The objective of the study is to decide on the sizing of the BESS when providing the primary frequency control. In grid-connected mode, the main grid provides stability for the frequency and voltage and all DGs operates in PQ mode. When the MG operates in islanded mode, the low inertia and small time-constants can lead to unstable operation and changes in frequency and voltage. According to Aghamohammadi and Abdolahinia (2014), frequency and voltage can be regulated by applying frequency-droop and voltage-droop control strategies. However, the BESS is the main regulating unit for the study due to the BESS is being able to provide fast dynamic response and inertia. The second control involves power-sharing between the DGs using the droop mechanism. The BESS will provide the reference for the frequency and voltage in islanded mode and it is modelled as a voltage source inverter (VSI).

## 4. CURRENT STUDY

This section holds information and details about the main part of this study and how it has been conducted. Data from the two MGs are presented separately, first Ludvika which is followed by Ålem. Collected data for the turbines, generators and the loads are presented, as well as curve fittings and combination curve which are input data for the simulations. The two MGs are explained, including MG formation and simulation.

### 4.1. Ludvika

VB Elnät is the owner of the electricity network in Ludvika and some nearby municipalities. They are responsible for operation and maintenance of 270 km of regional lines, 2800 km distribution lines, 918 network stations and 21 distribution stations. The electricity network annually distributes approximately 1 TWh to 28000 low voltage costumers and 50 high voltage costumers, which ranges between industries, companies, villas and apartments. (VB Energi, n.d.)

The system in Ludvika includes PV panels and a diesel generator as well, however, these will not be considered in this evaluation.

#### 4.1.1. *Microgrid formation*

The formation of an isolated MG will be set into motion if an event of a massive fault in the national grid occurs. When changing to operation in island mode, the local electricity network is downsized by decoupling from the national grid and forms a MG that includes the hydropower plant, the BESS and the prioritised loads. The MG will have to be restarted from black start. Initially, the BESS will provide electricity to the prioritised loads presented in Table 1 for six hours. During this time, the operation to prepare the electricity network for island mode will be set in motion. The hydropower plant must be started as this is the source that will provide the loads with electricity.

#### 4.1.2. *Simulation*

At the start of the simulation, the hydropower plant is running, and three prioritised loads are connected. It is assumed that the battery is fully charged at the start of the simulation. The second group of loads are hypothetical and defined by a previous study by Forsling and Rasouli (2017).

The loads are set as events in PowerFactory and it triggers variations of frequency and voltage. The order of connection of the loads is based on the size of the loads, smallest to largest. The connection time is not defined in previous research and is therefore set to estimated values.

The microgrid in Ludvika has been constructed to enable the possibility to operate isolated from the national grid. The hydropower plant in Ludvika can be operated in island mode due to the hydropower contains control of frequency. The frequency is controlled with means of wicket gate.

The initial condition of the hydropower model showed some problems with the size of the loads. As the three connected loads at the start of the simulation were too small, it was not possible to find a valid combination for the combination curve. Due to this, a baseload of 600 kW was connected during the simulation. This affects the system in the way that it does not completely represent the real scenario. The aim of the simulation is to see how the system behaves at changes in load, which is not affected by the baseload.

#### **4.1.3. Ludvika electricity network**

The electricity network in Ludvika is modelled in the PowerFactory tool and includes 5315 m of power lines. Group 1 of the loads are situated at the bottom part of Figure 4 and the BESS is situated inside the green box. Group 2 of Ludvika loads are located in the top right corner and the blue square in the left corner is where the hydropower plant is located. The substations are anonymised and replaced with letters as names.

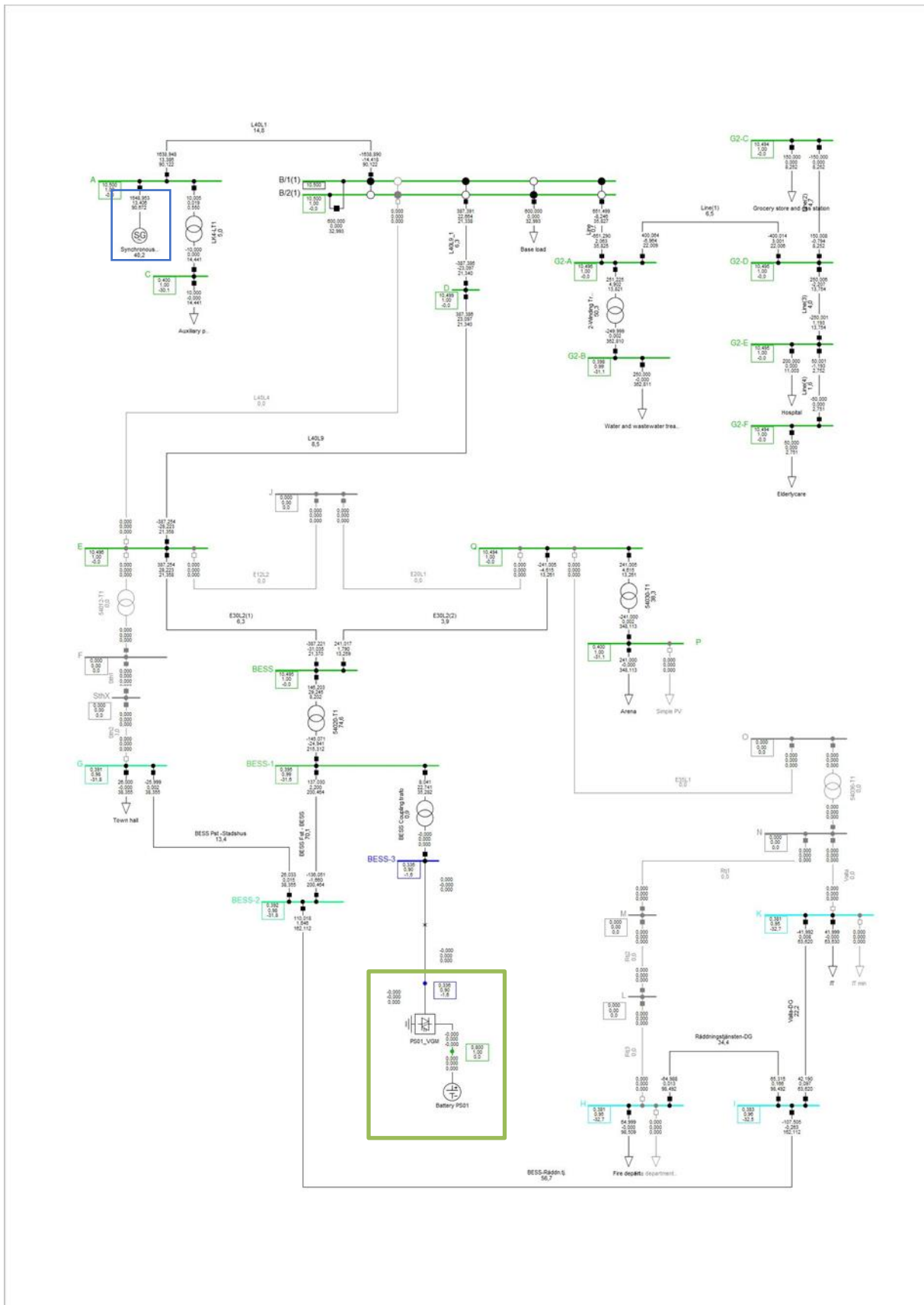

Figure 4 Line diagram in PowerFactory of Ludvika electricity network

Group 1 of the loads in Ludvika includes the town hall, IT-office, fire department and the arena. The first three of these have prior to this been considered as prioritised loads for the operation of the Ludvika community in island mode. The arena will work as a gathering point and provides a warm place for the residents and will be connected after starting the hydropower. The second group of loads, group 2, are hypothetical loads which can be connected in island operation. It is the water and wastewater treatment plant, the hospital, elderly care and the grocery store and gas station.

*Table 1 Ludvika max loads*

<b>Ludvika max loads</b>	
<b>Group 1</b>	
<b>Town hall</b>	26 kW
<b>IT-office</b>	42 kW
<b>Fire department</b>	65 kW
<b>Arena</b>	241 kW
<b>Group 2</b>	
<b>Water and wastewater treatment plant</b>	250 kW
<b>Hospital</b>	200 kW
<b>Elderly care</b>	50 kW
<b>Grocery store and gas station</b>	150 kW

#### **4.1.4. Ludvika data**

The generator in Ludvika has a power capacity of 4100 kVA and a power factor of 0.9. Total inertia includes both the flywheel and the generator and equals 18190 kgm<sup>2</sup>.

*Table 2 Ludvika generator data*

<b>Ludvika Generator data</b>		
<b>Power</b>	4 100	kVA
<b>Voltage</b>	10 500	V
<b>Power factor</b>	0,9	
<b>Current</b>	225	A
<b>Frequency</b>	50	Hz
<b>Speed</b>	273	1/min
<b>Total inertia</b>	18 190	kgm <sup>2</sup>

The full opening of the wicket gates is 430 mm at 100%. The opening and closing time for the wicket gate is 8 s, which after calculation equals 12.5 %/s. At 100% open, the runner blades have an opening of 96.9 mm. The total time for opening and closing is 20 s and thereby gives an opening and closing time of 5 %/s.

Table 3 Ludvika turbine data

Ludvika Turbine data		
<b>Wicket gate speed opening</b>	12.5	%/s
<b>Wicket gate speed closing</b>	12.5	%/s
<b>Runner blade speed opening</b>	5.0	%/s
<b>Runner blade speed closing</b>	5.0	%/s

The PID-parameters for the Ludvika power plant can be seen in Appendix B. The parameters are given but needed adaption.

#### 4.1.5. Curve fitting

The efficiency for the turbine is dependent on the opening for the wicket gate and the runner blades. Index tests which show the correlation between these variables have been conducted at the Ludvika power plant. The data has been treated in the curve fitting tool in MATLAB to attain equation 1 and the parameters in Table 4. The correlation between the input data and the equation is presented in Table 5. An R-square value of 0.98 and root mean square error (RMSE) of 0.23 indicates that the equation is a good fit for the input data.

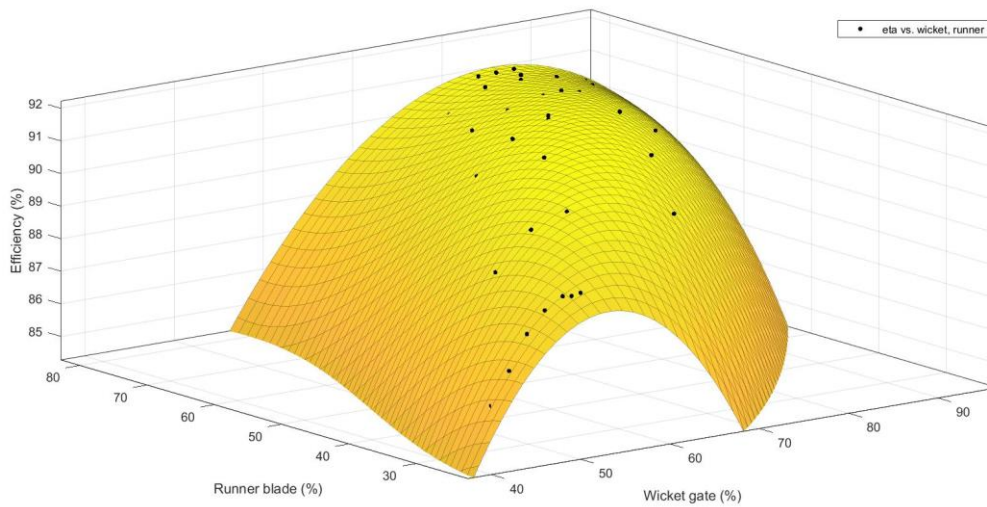

Figure 5 Curvefitting efficiency Ludvika

$$\eta(x, y) = p00 + p10 * x + p01 * y + p20 * x^2 + p11 * x * y + p02 * y^2 + p21 * x^2 * y + p12 * x * y^2 + p03 * y^3 \quad (1)$$

Table 4 Coefficients efficiency curve

Coefficients (with 95% confidence bounds)		
<b>p00</b>	46.24	(39.68, 52.81)
<b>p10</b>	1.778	(1.427, 2.128)

<b>p01</b>	-0.4033 (-0.6086, -0.198)
<b>p20</b>	-0.02344 (-0.02878, -0.0181)
<b>p11</b>	0.01802 (0.01139, 0.02466)
<b>p02</b>	-0.008569 (-0.01307, -0.004065)
<b>p21</b>	0.0001909 (8.554e-05, 0.0002963)
<b>p12</b>	-0.0002858 (-0.0004359, -0.0001357)
<b>p03</b>	0.000142 (7.851e-05, 0.0002054)

Table 5 Goodness of fit

Goodness of fit	
<b>SSE</b>	2.165
<b>R-square</b>	0.9793
<b>Adjusted R-square</b>	0.9752
<b>RMSE</b>	0.2326

The mass flow is also dependent on the opening for the wicket gate and the runner blades which in turn also requires a curve fitting. Equation 2 and the coefficients in Table 6 gives the mass flow. The R-square is 1 and the RMSE is 0.03.

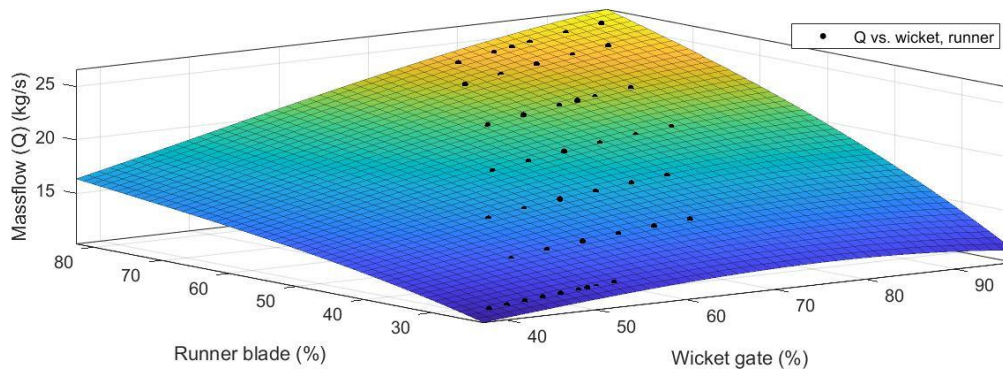

Figure 6 Curvefitting mass flow Ludvika

$$Q(x, y) = p00 + p10 * x + p01 * y + p20 * x^2 + p11 * x * y + p02 * y^2 + p30 * x^3 + p21 * x^2 * y + p12 * x * y^2 + p03 * y^3 \quad (2)$$

Table 6 Coefficients curve fitting mass flow

Coefficients (with 95% confidence bounds)	
<b>p00</b>	5.359 (3.253, 7.465)
<b>p10</b>	-0.01326 (-0.1896, 0.1631)
<b>p01</b>	0.1494 (0.0335, 0.2652)
<b>p20</b>	0.001218 (-0.003723, 0.006158)
<b>p11</b>	0.002239 (-0.004231, 0.008708)
<b>p02</b>	-0.001782 (-0.003972, 0.000408)
<b>p30</b>	-1.489e-05 (-6.023e-05, 3.044e-05)

<b>p21</b>	1.292e-05 (-7.665e-05, 0.0001025)
<b>p12</b>	-1.365e-05 (-7.479e-05, 4.749e-05)
<b>p03</b>	9.711e-06 (-5.731e-06, 2.515e-05)

Table 7 Goodness of fit

Goodness of fit	
<b>SSE</b>	0.04759
<b>R-square</b>	1
<b>Adjusted R-square</b>	0.9999
<b>RMSE</b>	0.03493

The combination curve gives the best combination for the opening for the wicket gate and the runner blades at the highest efficiency. The values are in percent with runner blades on the y-axis and the wicket gate on the x-axis. The curve in Figure 7 is given by equation 3 and the coefficients in Table 8.

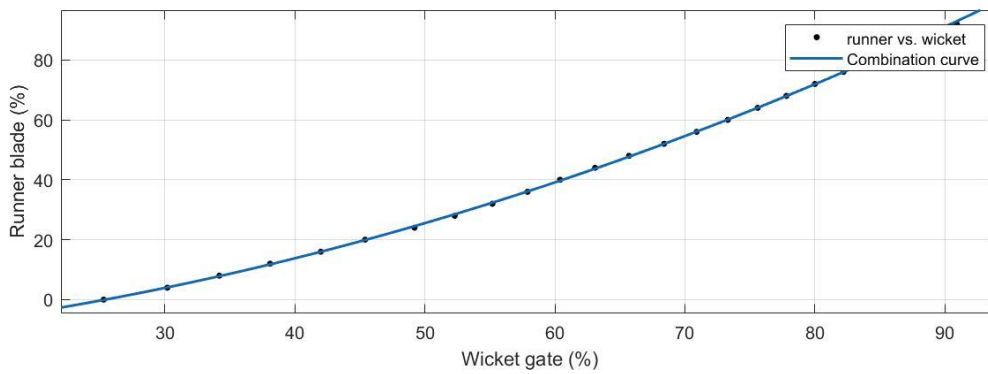

Figure 7 Combination curve

$$f(x) = p1 * x^2 + p2 * x + p3 \quad (3)$$

Table 8 Coefficients curve fitting combination curve

Coefficients (with 95% confidence bounds)	
<b>p1</b>	0.0093 (0.008874, 0.009727)
<b>p2</b>	0.3369 (0.2856, 0.3882)
<b>p3</b>	-14.57 (-16.01, -13.13)

Table 9 Goodness of fit combination curve

Goodness of fit	
<b>SSE</b>	2.456
<b>R-square</b>	0.9999
<b>Adjusted R-square</b>	0.9999
<b>RMSE</b>	0.342

## **4.2. Ålem**

The electricity network in Ålem is owned by Ålem Energi which are responsible for 39200 km of lines for 3285 costumers. 2017 they distributed 46.17 GWh of electricity through low voltage cables of 12 and 24 kV distribution lines and 107 distribution stations. (Ålem Energi, n.d.)

### **4.2.1 Microgrid formation**

There is no specification of how the formation of the MG will take place in Ålem. It is however decided which loads that should be connected and provided with electricity. There are three loads included in the MG network and two of these should be provided with electricity, Skälleryd and Skäppentorp. It is based on the assumption that the third load, the furniture factory, is not considered essential for society.

### **4.2.2 Simulation**

The current microgrid in Mönsterås does not have frequency control and is therefore not prepared for operation in island mode. A previous study at SWECO (Fredriksson, 2019) has investigated how the MG can be operated when adding frequency control to the hydropower in island mode.

The study evaluates four different scenarios:

- Wicket gate without BESS
- Wicket gate with BESS
- Runner blade without BESS
- Runner blade with BESS

As the current hydropower plant in Ålem does not have frequency control, two different methods are considered, frequency control be means of wicket gate and runner blade. Both methods are considered with and without the BESS.

For this study, it is assumed that the BESS is fully charged at the start of the simulation. No loads should be connected, however, due to problems with the combination curve the furniture factory is set as a baseload. When simulating, the program is not able to find a valid combination when the power is low. Because of this, the system does not represent the real scenario in full, it is however, still possible to see the behaviour of the system. The order for connection of loads is decided based on the size of the loads, connecting the smallest load first.

### **4.2.3 Ålem electricity network**

The MG in Ålem consists of 1945 m of power lines. The scheme of the electricity network that are built in PowerFactory is illustrated in Figure 8. Cable lengths and details and location in the network is based on data from Ålem Energi. Distribution transformers are not considered

in the scheme as data for these have not been provided in full. The blue box at the top of the figure contains the hydropower plant and the green box at the bottom of the figure holds the BESS. The BESS is placed in Skälleryd according to the scheme, which is an assumption and not based on real information as it is not given.

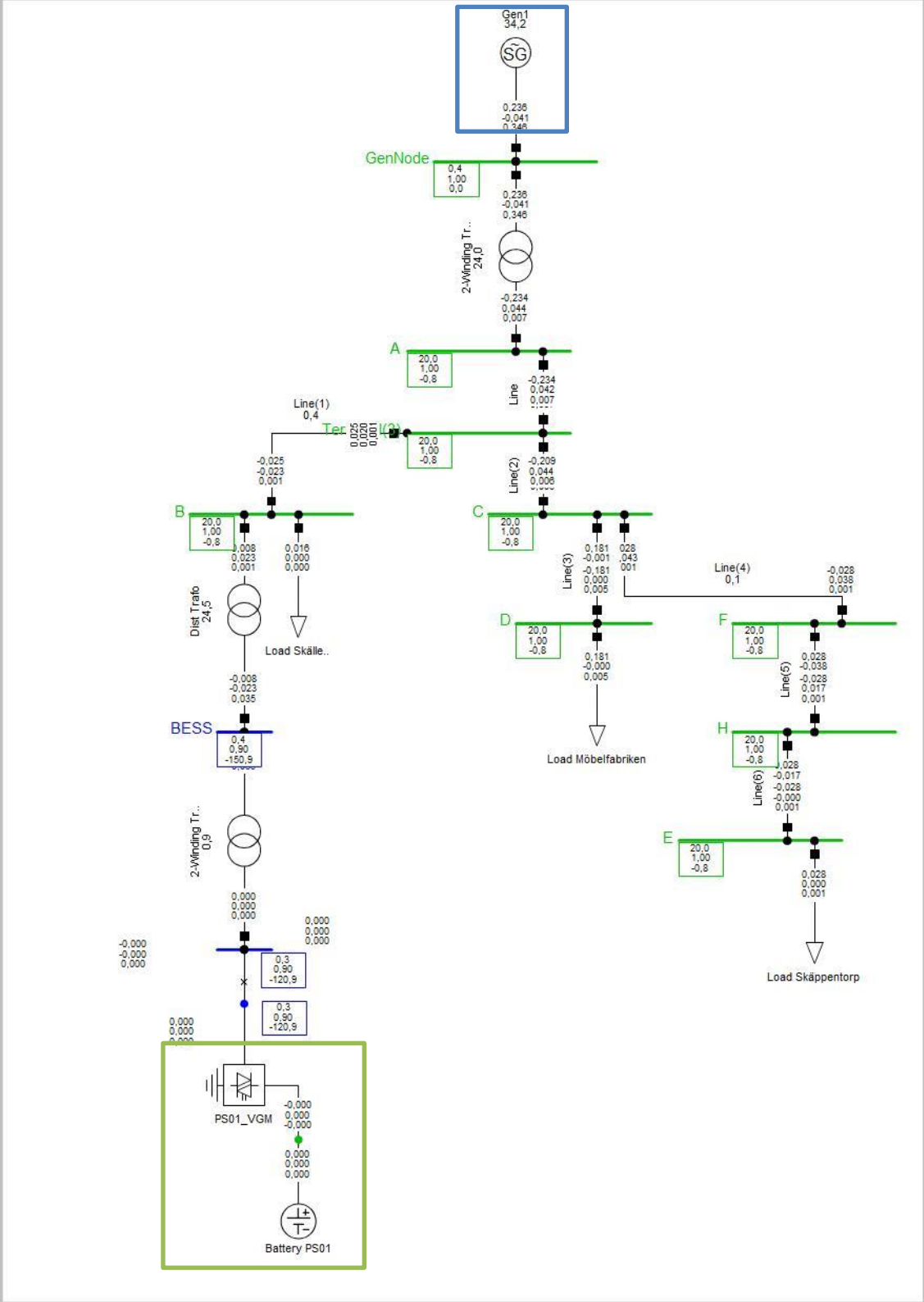

Figure 8 Line diagram in PowerFactory of Ålem electricity network

The max loads were calculated with the Velander formula in previous studies. Real data for the loads is not given with respect to the network owners.

Table 10 Ålem max loads

Ålem max loads	
<b>Skälleryd</b>	16.1 kW
<b>Skäppentorp</b>	28.2 kW
<b>Furniture factory</b>	181 kW

#### 4.2.4 Ålem data

The generator in Ålem has a power capacity of 700 kVA and a power factor of 0.9. Total inertia is the inertia for the generator and the runner as Ålem does not have a flywheel as the one in Ludvika does.

Table 11 Ålem generator data

Ålem Generator data		
<b>Power</b>	700	kVA
<b>Voltage</b>	400	V
<b>Power factor</b>	0.9	
<b>Current</b>	1 010	A
<b>Frequency</b>	50	Hz
<b>Speed</b>	250	1/min
<b>Total inertia</b>	960	kgm <sup>2</sup>

The time it takes for the wicket gate to go from fully closed to fully open is measured to 45 s and the closing time is 5 seconds slower at 50 s. The simulation requires a speed for the opening and closing time. As the maximum wicket gate opening is not known this is attained from the Simulink model from the hydropower model. The model contains a counterweight unit and a counterweight regulator which represents the regulation of the wicket gates. The opening and closing time for the runner blades is 35° per 45 s which gives a speed of 0.7778 °/s.

Table 12 Ålem turbine data

Ålem Turbine data		
<b>Wicket gate speed opening</b>	2.6	mm/s
<b>Wicket gate speed closing</b>	1.3	mm/s
<b>Runner blade speed opening</b>	0.7778	°/s
<b>Runner blade speed closing</b>	0.7778	°/s

#### 4.2.5 Curve fitting

Curve fitting of the mass flow, efficiency and the combination curve have been conducted by the previous study. Equation 3 gives the efficiency with coefficients in Table 13. The mass

flow is given by equation 4 and the coefficients in Table 14. Lastly, equation 5 gives the combination curve and the runner blade opening.

$$\eta(x,y) = p00 + p10.*x + p01.*y + p20.*x.^2 + p11.*x.*y + p02.*y.^2 + p30.*x.^3 + p21.*x.^2.*y + p12.*x.*y.^2 + p03.*y.^3 \quad (3)$$

Table 13 Coefficients curve fitting efficiency

Coefficients	
<b>p00</b>	0.7505
<b>p10</b>	0.004089
<b>p01</b>	-0.05208
<b>p20</b>	-2.201e-05
<b>p11</b>	0.0008096
<b>p02</b>	-0.001948
<b>p30</b>	-8.915e-08
<b>p21</b>	-7.833e-07
<b>p12</b>	-1.541e-06
<b>p03</b>	2.102e-05

$$Q(f,x) = p00 + p10.*x + p01.*y + p20.*x.^2 + p11.*x.*y + p02.*y.^2 \quad (4)$$

Table 14 Coefficients curve fitting mass flow

Coefficients	
<b>p00</b>	0.6031
<b>p10</b>	0.0227
<b>p01</b>	0.1346
<b>p20</b>	-3.968e-05
<b>p11</b>	0.001015
<b>p02</b>	-0.001584

$$Runner = 0.0012 * x^2 - 0.0739 * x - 0.1642 \quad (5)$$

### 4.3. The BESS

The model is based on data from an existing BESS and the model in PowerFactory is attained from the manufacturer. The BESS includes a lithium-ion battery with a capacity of 400 kWh and an inverter with a rated power of 95 kVA for Ålem and 90 kVA for Ludvika. The same model is applied for both the Ludvika case and the Ålem case.

Table 15 BESS parameters

BESS	
<b>Rated power Ålem</b>	95 kVA
<b>Rated power Ludvika</b>	90 kVA
<b>Capacity</b>	400 kWh

There are a lot of different parameters that can be changed in the model for the BESS. However, the time is limited, and the focus will, therefore, be to adjust the frequency droop parameter, fdroop. The default value for the fdroop is 0.04. Other parameters will be kept at default values.

#### 4.4. Verification of the model

The hydropower plant model is based on an existing model designed in the MATLAB tool Simulink. Verification of the hydropower plant designed in PowerFactory was conducted to conclude the quality of the model. Figure 9 illustrates the result of the verification test, where the green line is the reference from the Simulink model and the red is the frequency curve for the PowerFactory simulation. A switch event with load connection occurs after 1500 s and triggers the frequency deviation which is zoomed in in Figure 10. The two curves closely align which indicates that the PowerFactory model corresponds to the Simulink model. The Simulink model has an oscillating frequency at the start of the simulation before the frequency settles at 50 Hz. As this is not accurate for a real power plant model, the initializing of the PowerFactory model is constructed so that the frequency is stable at 50 Hz. Consequently, improving the performance of the original model.

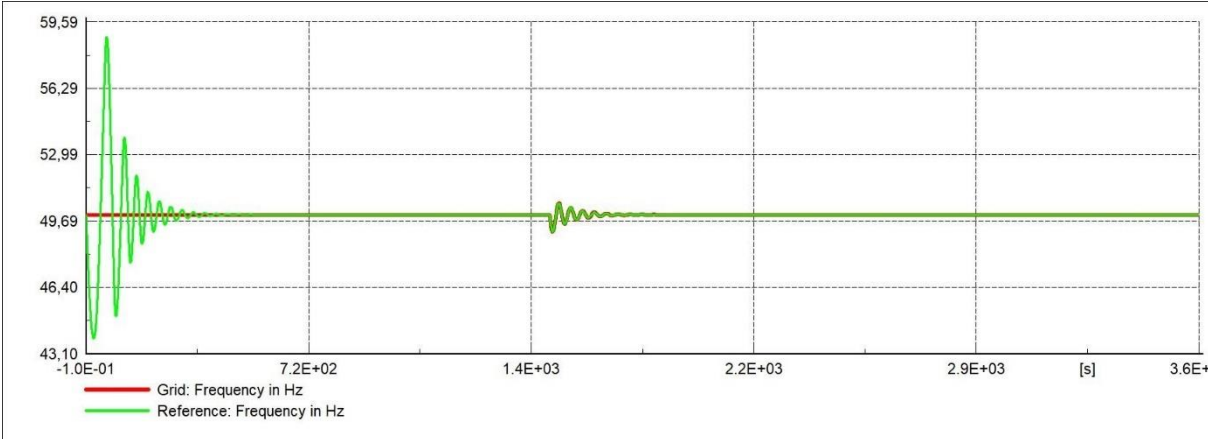

Figure 9 Verification of model

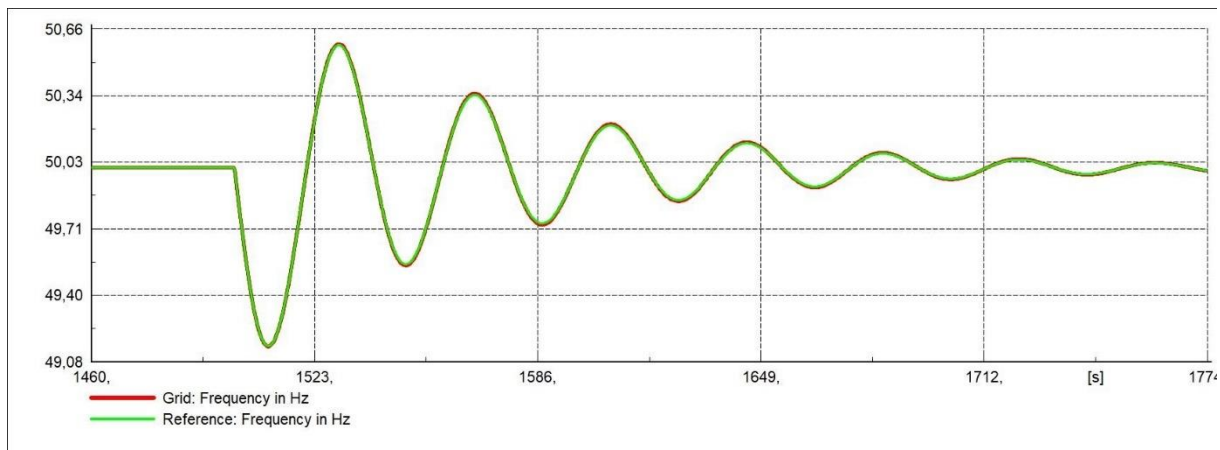

Figure 10 Verification of model zoomed

## 5 RESULTS

The results from the simulations are presented in this section. To begin with, the Ålem scenario with frequency control by means of wicket gate is presented without the BESS and with BESS. Followed by the simulations with frequency control by runner blade, without and with BESS. As the Ludvika scenario contains frequency control by means of wicket gate, only two scenarios are presented, with and without BESS.

### 5.1 Ålem

The current hydropower plant in Ålem does not have a control system for frequency control, which is required for island operation. Two different methods for frequency control are therefore tested; frequency control by wicket gate regulation and by runner blade regulation.

The aim was to start the simulation with no load and thereafter connect the loads at different times to see the frequency deviation and how the system reacts. However, this is not possible because there is no valid combination from the combination curve for runner simulation at this point. The combination curve depends on the wicket gate opening and the angle of the runner blades. Therefore, one load is connected at the start of the simulation, the furniture factory. After 50 s Skälleryd is connected and after 100 s Skäppentorp is connected.

The simulation scenarios are evaluated and compared to each other, the load connection is therefore not changed between the two cases. The adaption of parameters is adjusted to fit the operation scenarios without the BESS connected. This means that they are not adapted according to the BESS scenario.

### 5.1.1. Wicket gate simulation

Frequency control by wicket gate regulation is applied in the first simulation. Given that there is no existing frequency control, the parameters for the PID controller requires adaption. As the control for the wicket gate is slow the parameters must be tuned in to attain a stable system. The attained PID-parameters can be seen in Appendix B.

Figure 11 and Figure 12 illustrates where the connection of loads triggers a deviation of frequency and voltage when connecting loads. Figure 11 illustrates the frequency in Hz with the green curve being without the BESS and the grey curve being with the BESS. The first load connection triggers a smaller deviation in frequency compared to the second load connection. This is because the first load is smaller than the second load, 16.1 kW and 28.2 respectively. When the first load is connected the frequency reaches below 46 Hz. The second load connection triggers a frequency deviation of 9 Hz, reaching a frequency of 41 Hz. The simulation time is 300 s.

When simulating the Ålem MG with the BESS connected, the parameters are the same as the scenario without the BESS. Simulation of the scenario with the default values for the BESS gives a frequency deviation higher than the approved deviation. By changing the fdroop from 0.04 to 0.02 the frequency does not go below 49 Hz. It is within acceptable range with a minimum of 49.19 Hz. After the first load connection the frequency reaches a minimum of 49.62 Hz. The regulation is too slow to succeed on returning the frequency to 50 Hz before the second load is connected at 100 s, which is also the case after the load connection.

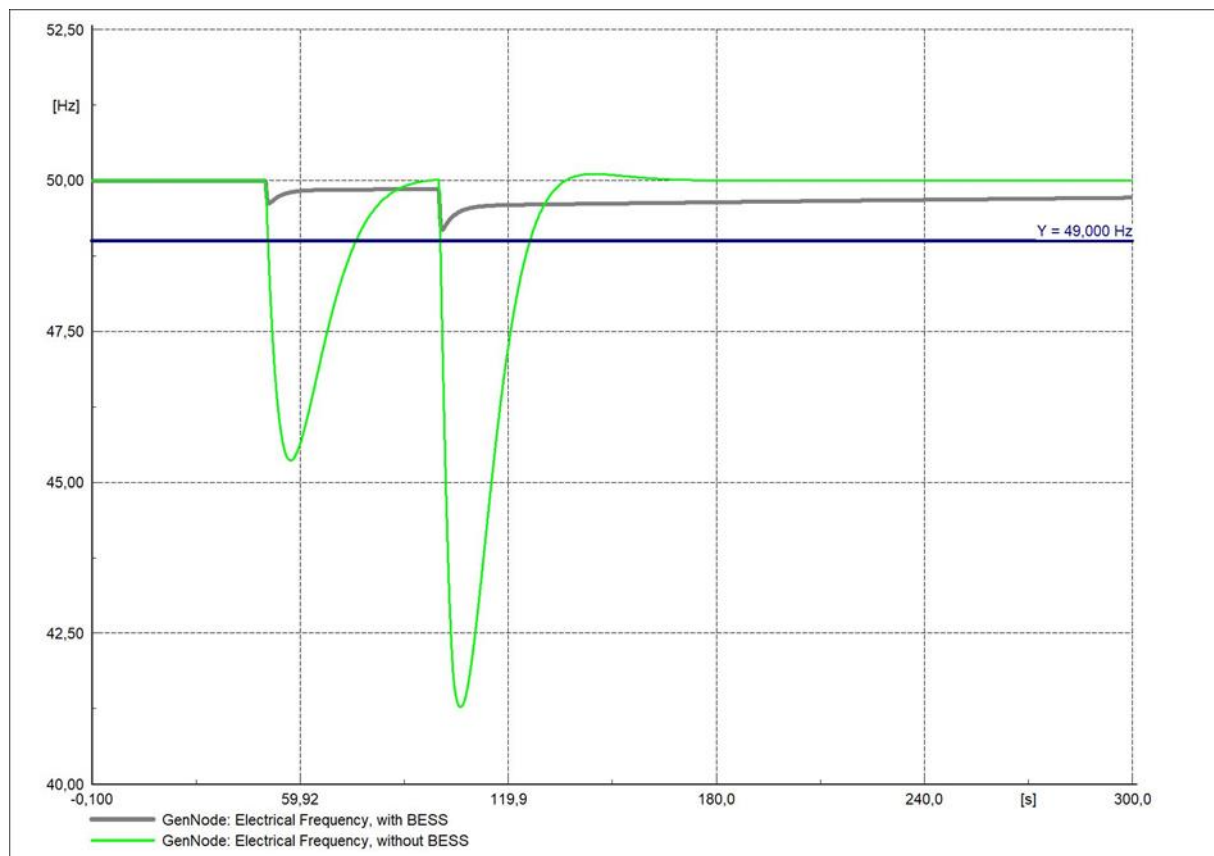

Figure 11 Ålem – Wicket gate; Frequency

In Figure 12 the blue curve illustrates the voltage with the BESS and the red without the BESS in per unit. The deviation of voltage is smaller than  $\pm 0,005$  p.u. for the first deviation and less than  $\pm 0,007$  p.u. for the second. Having the BESS connected helps reduce both the frequency and the voltage deviation.

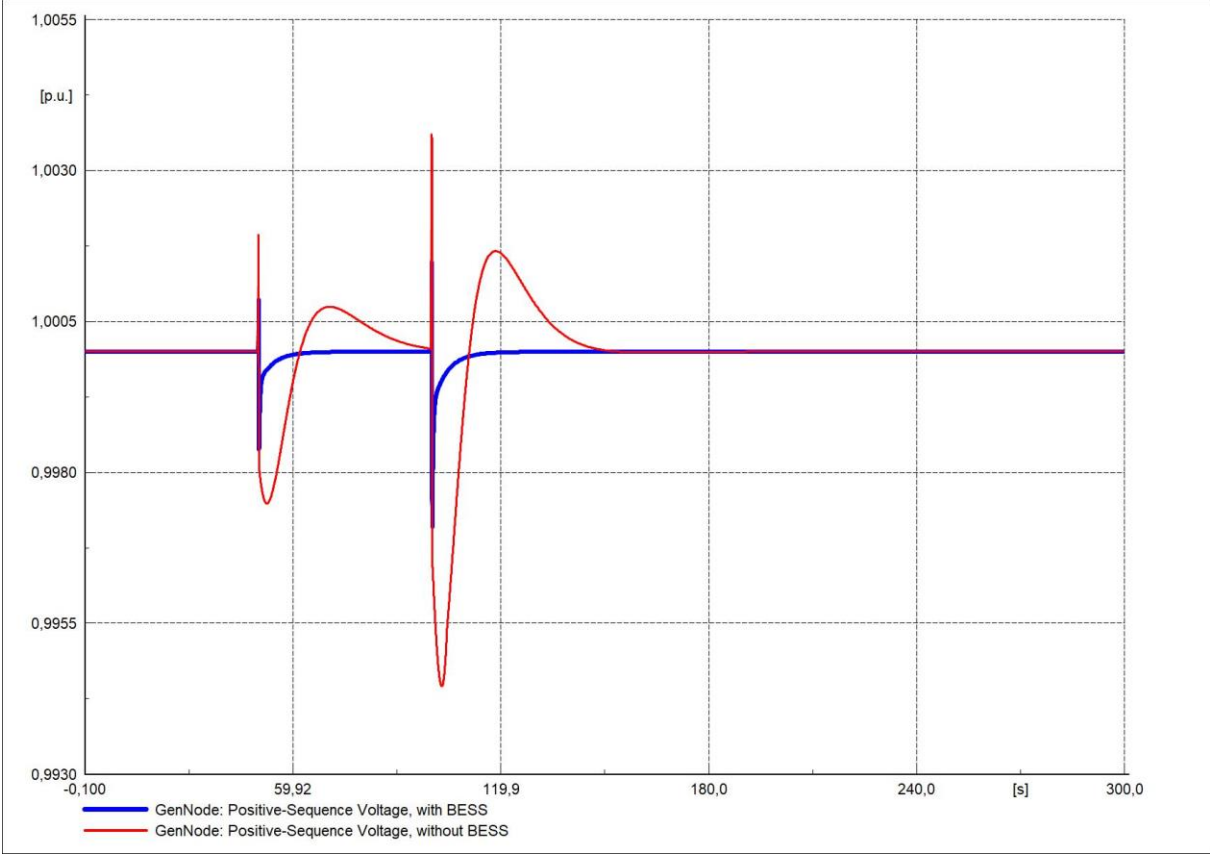

Figure 12 Ålem – Wicket gate; Voltage

The power from the turbine is regulated by the opening for the wicket gate and the angle of the runner, which is illustrated in Figure 13. As the power demand increase when loads are connected, the wicket gate and runner blade opening is regulated. It increases at time 50 s when Skälleryd is connected and again at time 100 s when Skäppentorp is connected. The green and red curve are the runner blade angle which is presented on the left axes in degrees and the blue and grey curve is the wicket gate opening in mm which is presented on the right axes. As the BESS provides power to the system, the need for regulation of wicket gate and runner is reduced. This does also cause the turbine power to be smaller compared to without the BESS. The missing power is provided by the BESS.

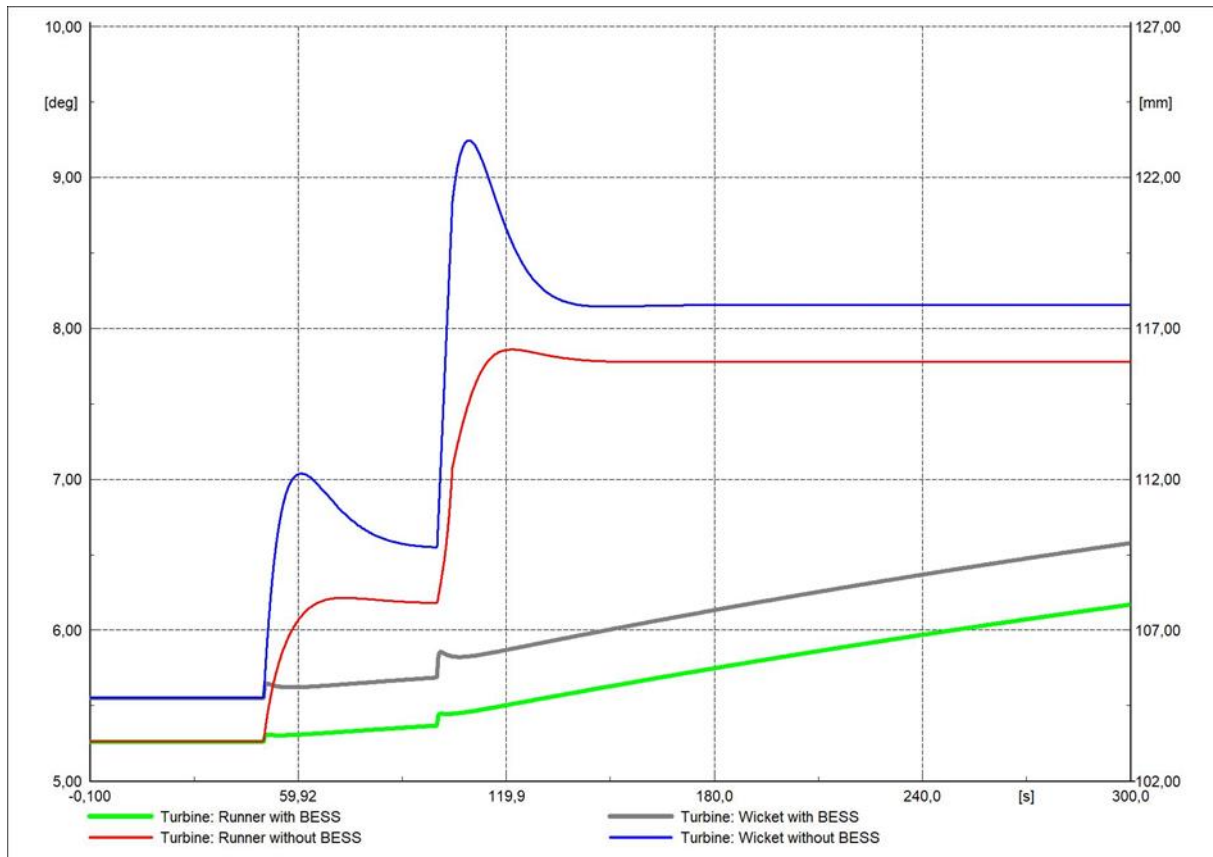

Figure 13 Ålem - Wicket gate; Regulation of runner blade and wicket gate

How much active power the BESS provides is given by the red curve in Figure 14. Connecting the Skälleryd load requires 15 kW and connection of the Skäppentorp load requires a total of 41 kW at time 100 s. As the active power from the BESS decreases, the wicket gates and the runner blades are increased to provide more active power from the turbine.

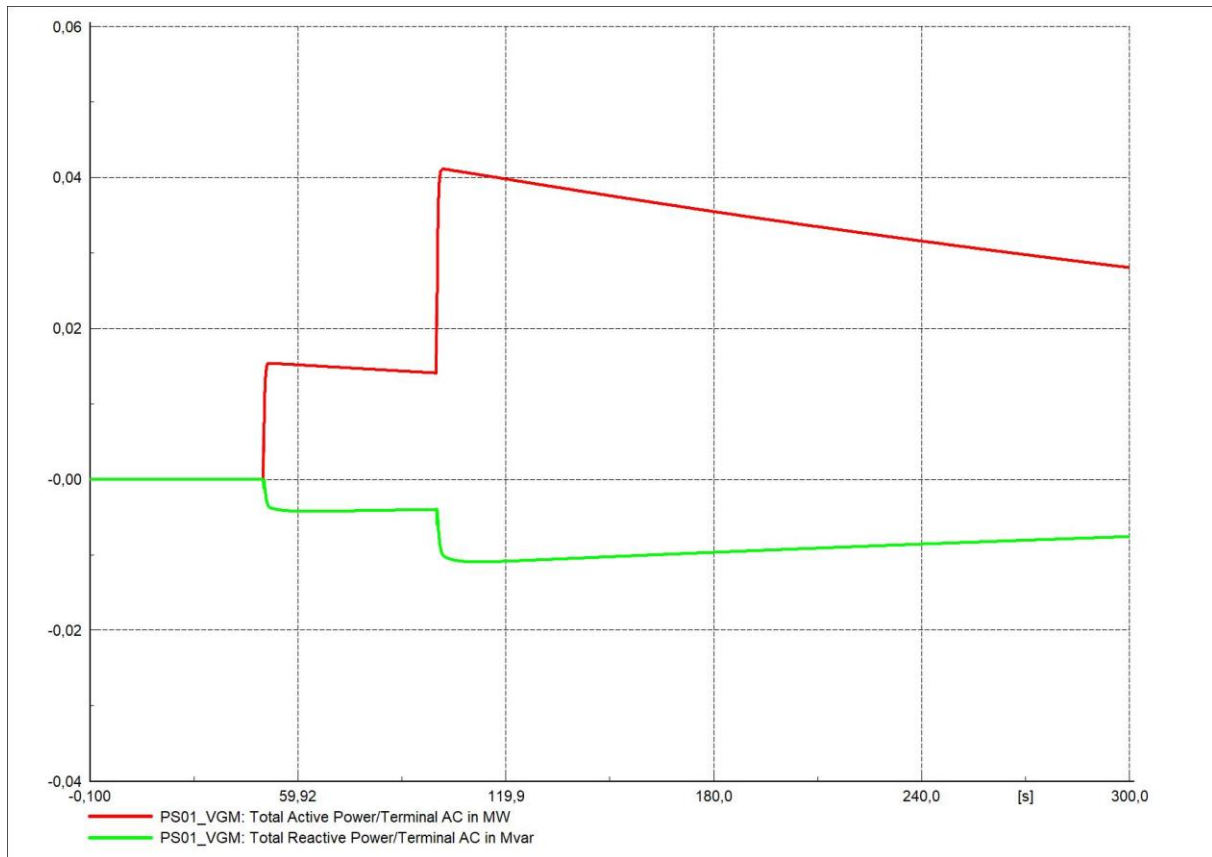

Figure 14 Ålem - Wicket gate; BESS power

### 5.1.2 Runner simulation

When simulating the scenario with frequency control by means of runner blade without BESS, a large dip in frequency occurs. As seen in Figure 15, connection of the largest load, Skäppentorp, leads to a frequency near 45 Hz and an overshoot of close to 1 Hz. Simulation of the model with the default values for the BESS resulted in a frequency at 49.11 Hz. By changing the fdroop value for the virtual generator from 0.04 to 0.02 the maximum frequency deviation reaches 49.3 Hz. The grey line in Figure 15 illustrates that the frequency deviation is lower than without the BESS which is the green line. With the BESS, there is no overshoot and the frequency take longer time before it returns to 50 Hz. Between the first and the second load connection the frequency does not return to set point when the BESS is included.

Both the frequency deviation and the voltage deviation are reduced by including the BESS in the system. In Figure 16, the red curve is the voltage without the BESS and the blue curve is with the BESS in p.u.. The voltage deviation does not exceed 0.005 p.u.

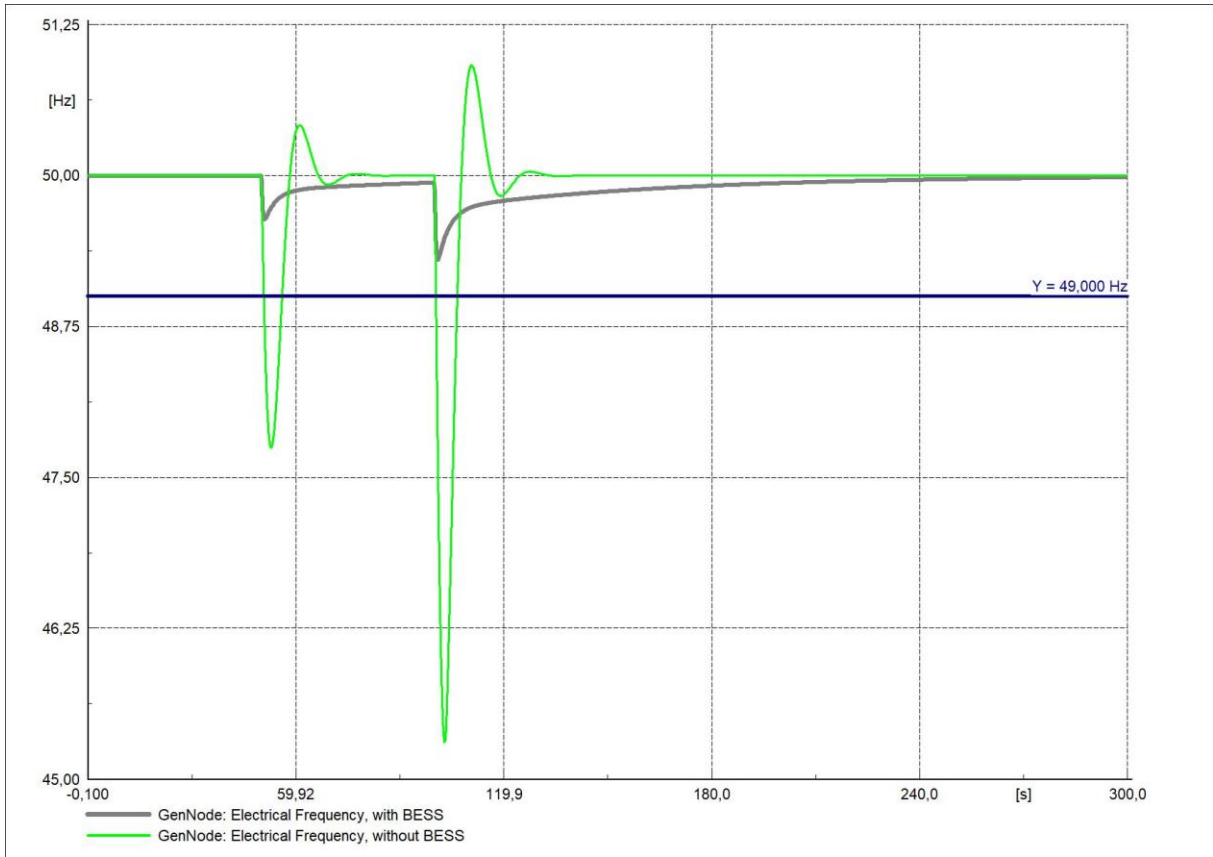

Figure 15 Ålem - Runner blade; Frequency

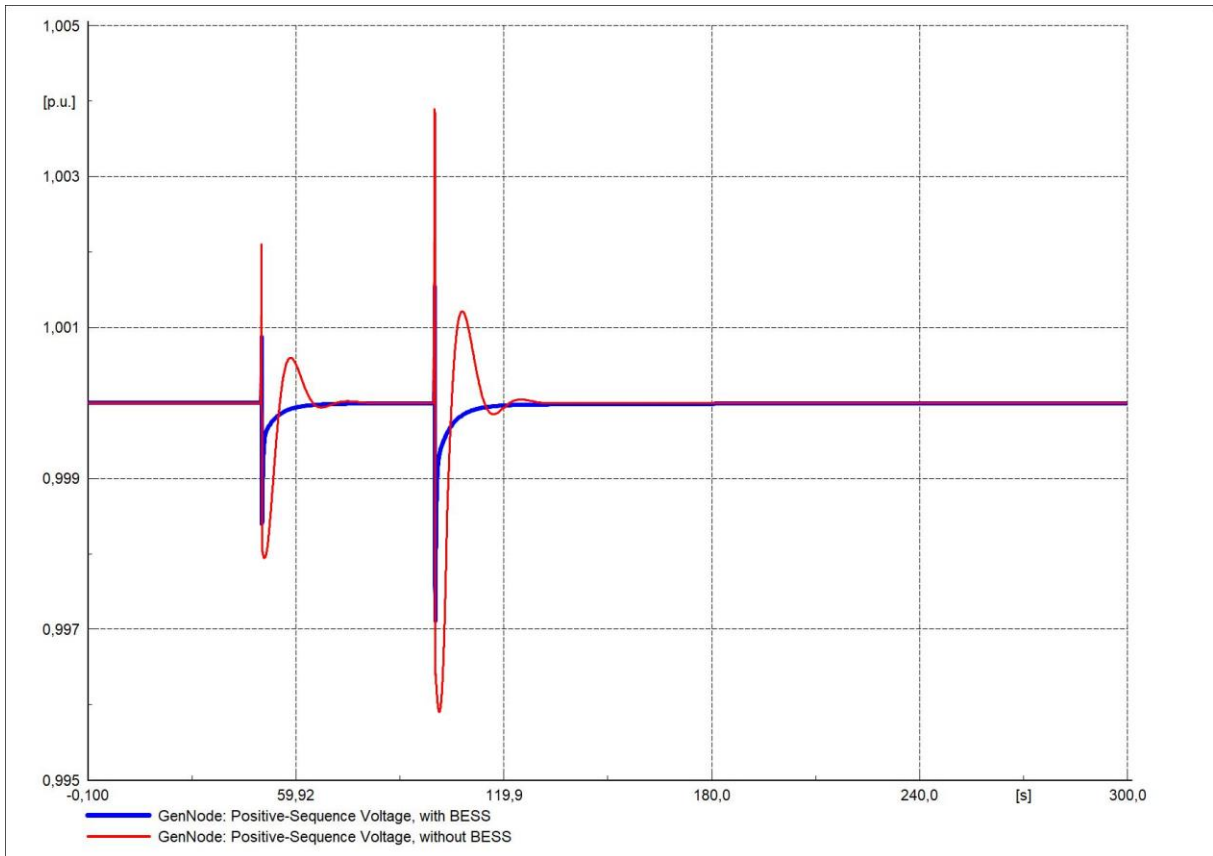

Figure 16 Ålem - Runner blade; Voltage

As the frequency decreases, the runner blade opening increases to stabilize the deviation and return it back to the set point at 50 Hz. Figure 17 **Fel! Hittar inte referenskälla.** shows how the runner blade opening in degrees varies for with BESS and without BESS. Comparing this result, including the BESS, with the result without the BESS shows that the regulation of the runner blades is a lot smaller. The reason for this can be seen in Figure 18 where the red line is the total active power in MW from the BESS.

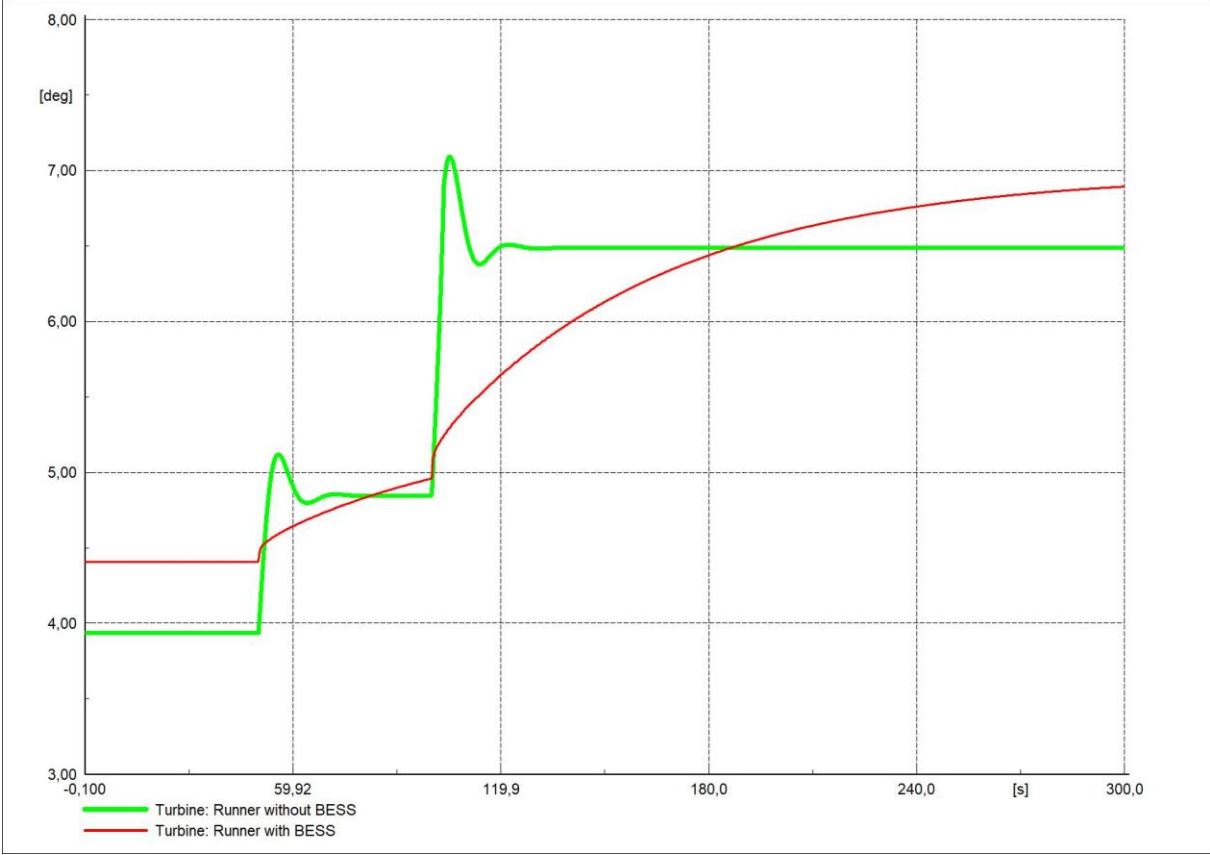

Figure 17 Ålem - Runner blade; Regulation

The total active and reactive power in MW and Mvar, respectively, are illustrated in Figure 18. The active power provided by the BESS reduces the regulation of runner blade in Figure 17.

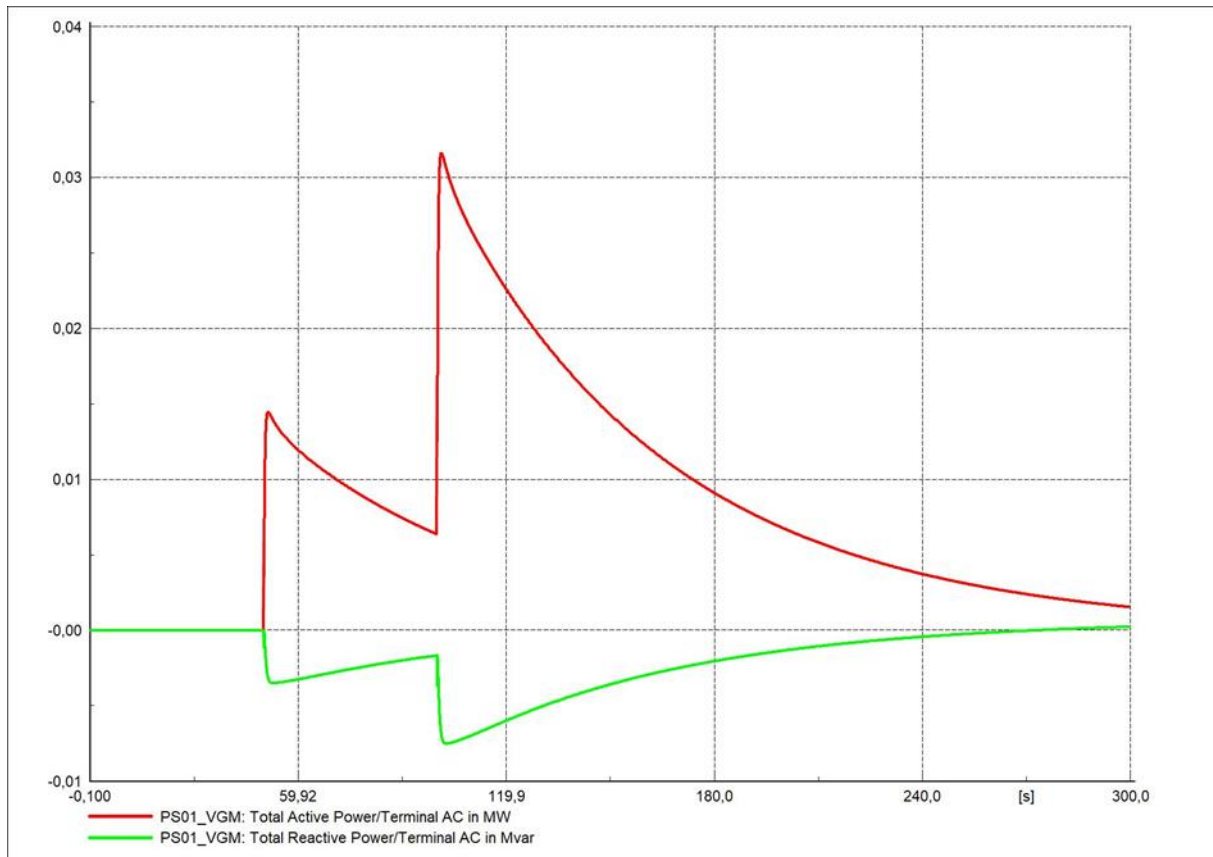

Figure 18 Ålem - Runner blade; BESS power

### 5.1.3. All scenarios

In order to easily compare the two different methods to one another they are all included in Figure 19. The two red curves are the runner blades with and without the BESS and the green curves are the wicket gate with and without the BESS. The two blue lines are set at 49 Hz and 51 Hz which is the range at which the frequency should not exceed. When the frequency is regulated with means of runner blade, the deviation is smaller both with and without the BESS. The difference in the dip is not that large when comparing the two cases that includes the BESS, the return time until the frequency has reached 50 Hz is however a bit faster when the frequency is regulated with means of runner blade.

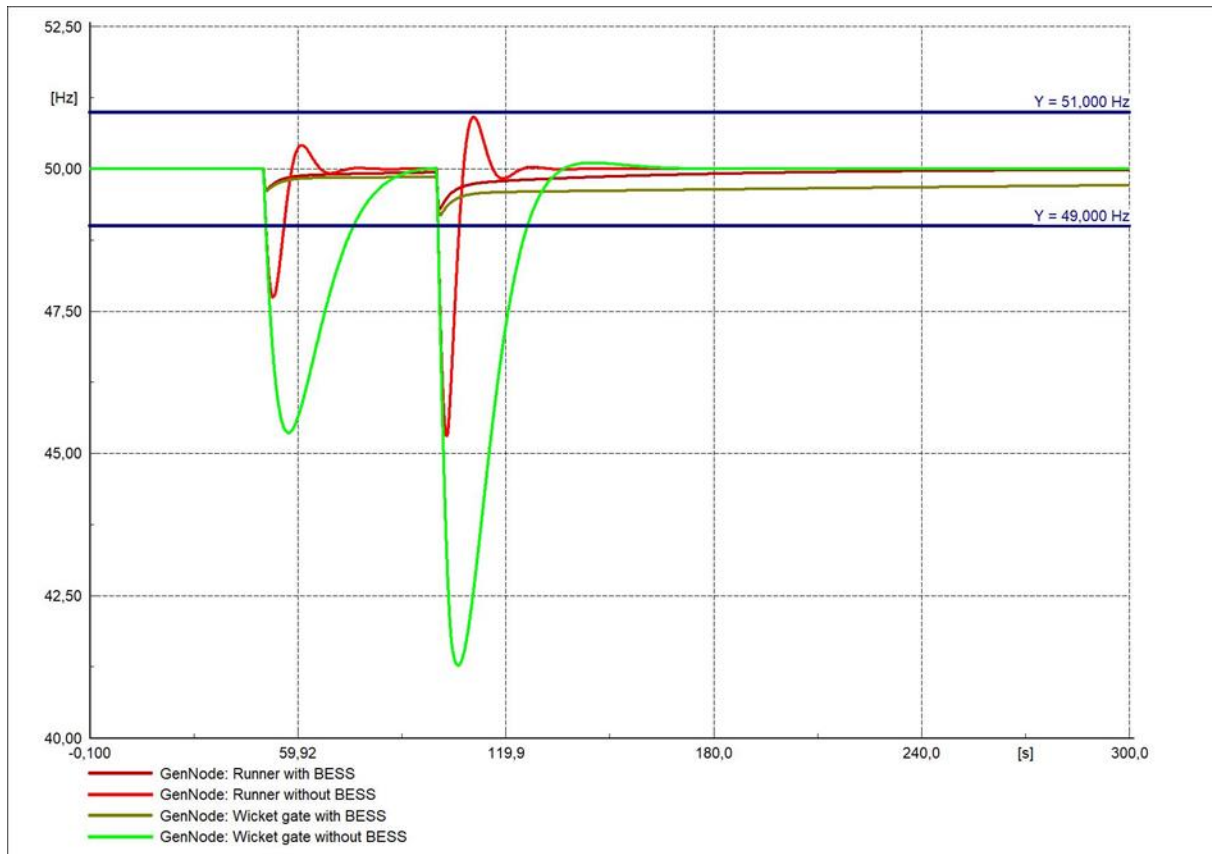

Figure 19 Ålem; all scenarios

## 5.2. Ludvika

The frequency is controlled by means of wicket gate in Ludvika. A base load of 600 kW is placed on the B substation which can be seen in Figure 4. The load connections are ordered after size, connecting the smallest load first and the largest load last. The simulations are executed for 1000 s.

The first load of 50 kW is connected after 30 s, causing a frequency deviation of approximately 0.4 Hz. The blue line is fixed at 49 Hz to illustrate the limit at which the frequency should not exceed. It is thereby only the first load connection that does not exceed the limit both with and without BESS. Giving the lowest frequency of just above 48 Hz when connecting the third load without BESS. As for the overshoot, it is approximately 0.6 Hz, thereby within the  $\pm 1$  Hz range.

When adding the BESS to the MG in Ludvika the frequency deviation is reduced. The green line in Figure 20 is the frequency without the BESS in Hz and the red line is the frequency with BESS. The first load connection of 50 kW is within the  $\pm 1$  Hz limitation. The second load of 150 kW is however not within acceptable range, yet, it is just slightly below 49 Hz. The maximum deviation of frequency is near 1.5 Hz and occurs for the two last load connections.

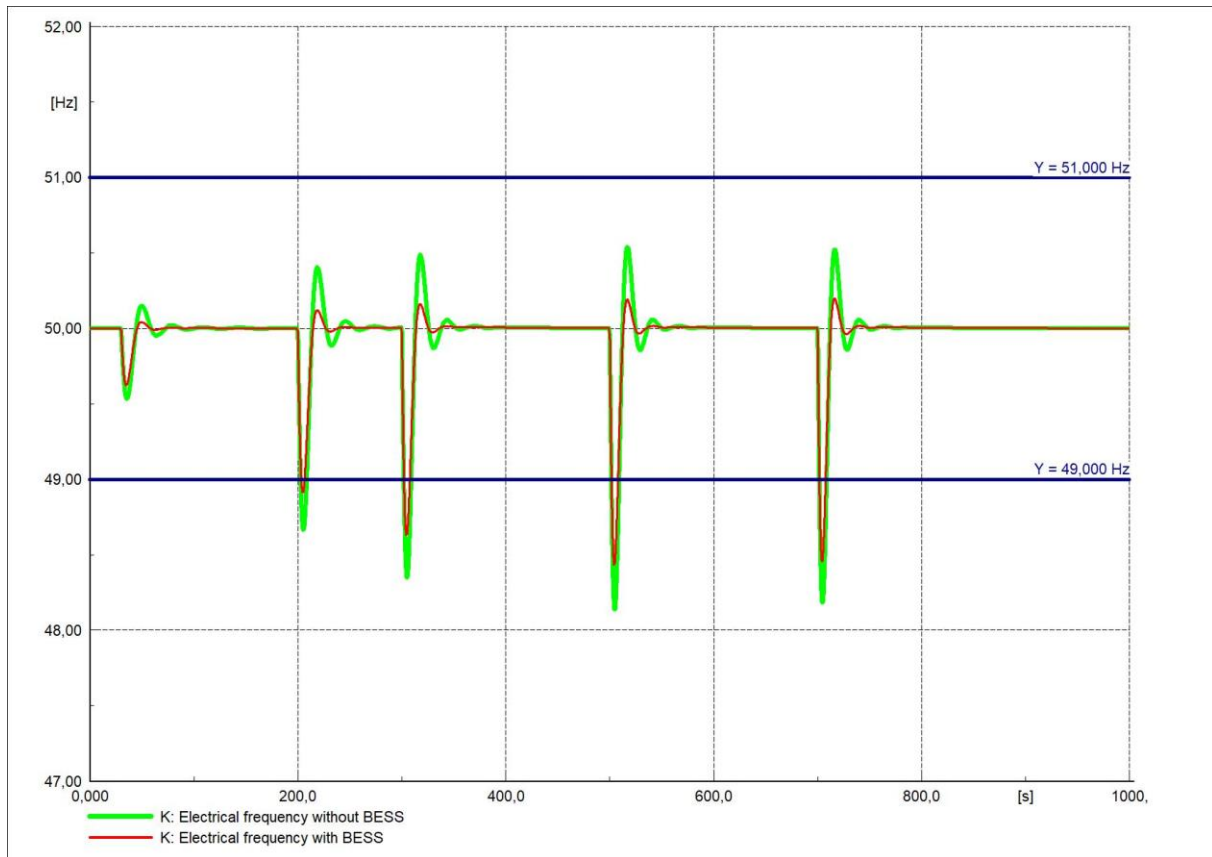

*Figure 20 Ludvika; Frequency*

The voltage should not deviate more than  $\pm 10\%$ . As the voltage is presented in p.u. in Figure 21, it cannot deviate more than  $\pm 0.1$ , attaining the limits of 1.1 and 0.9 p.u.. The voltage deviation differs depending on where the calculated point is situated in the grid. Figure 21 shows how the voltage varies for one substation in the MG and that the deviation is reduced with the BESS included. The substation that is situated the furthest away from the generator is slightly lower in voltage compared to the other substations. However, it is not in any risk of being below 0.9 p.u..

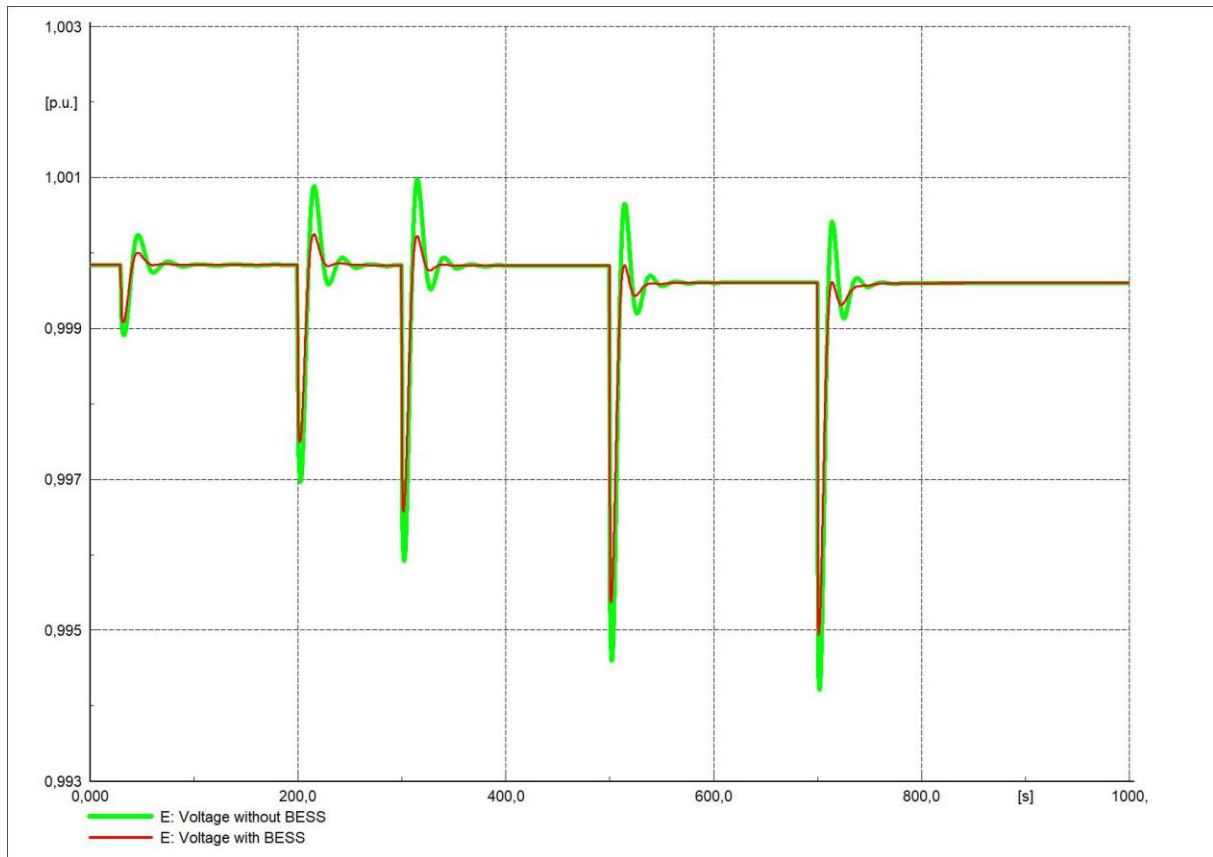

*Figure 21 Ludvika; Voltage*

The wicket gate and runner blade regulation time are presented in %. In Figure 22, these are illustrated in comparison to one another. The green and red line is the runner blade opening, whereas the blue and gray line is the wicket gate opening. Both curves follow the same pattern and as can be seen, both regulations operate fast. When including the BESS, the regulation at the maximum points are reduced as the BESS provides active power.

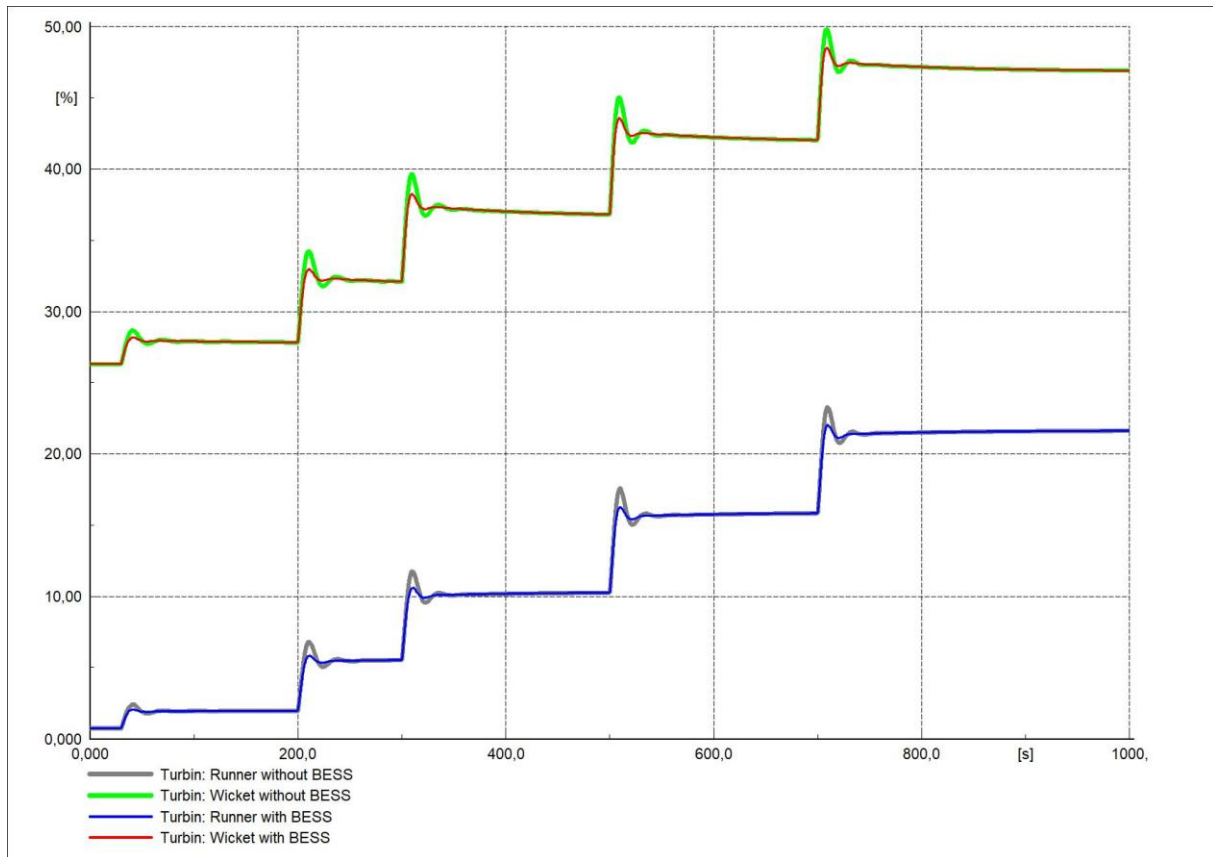

*Figure 22 Ludvika; Regulation of runner blade and wicket gate*

When the regulation of wicket gate and runner blade is reduced, the BESS provides active and reactive power accordingly. Figure 23 illustrates how much reactive power in kVA and active power in kW that is applied. The maximum active power is 48 kW, which is attained for the second last load connection.

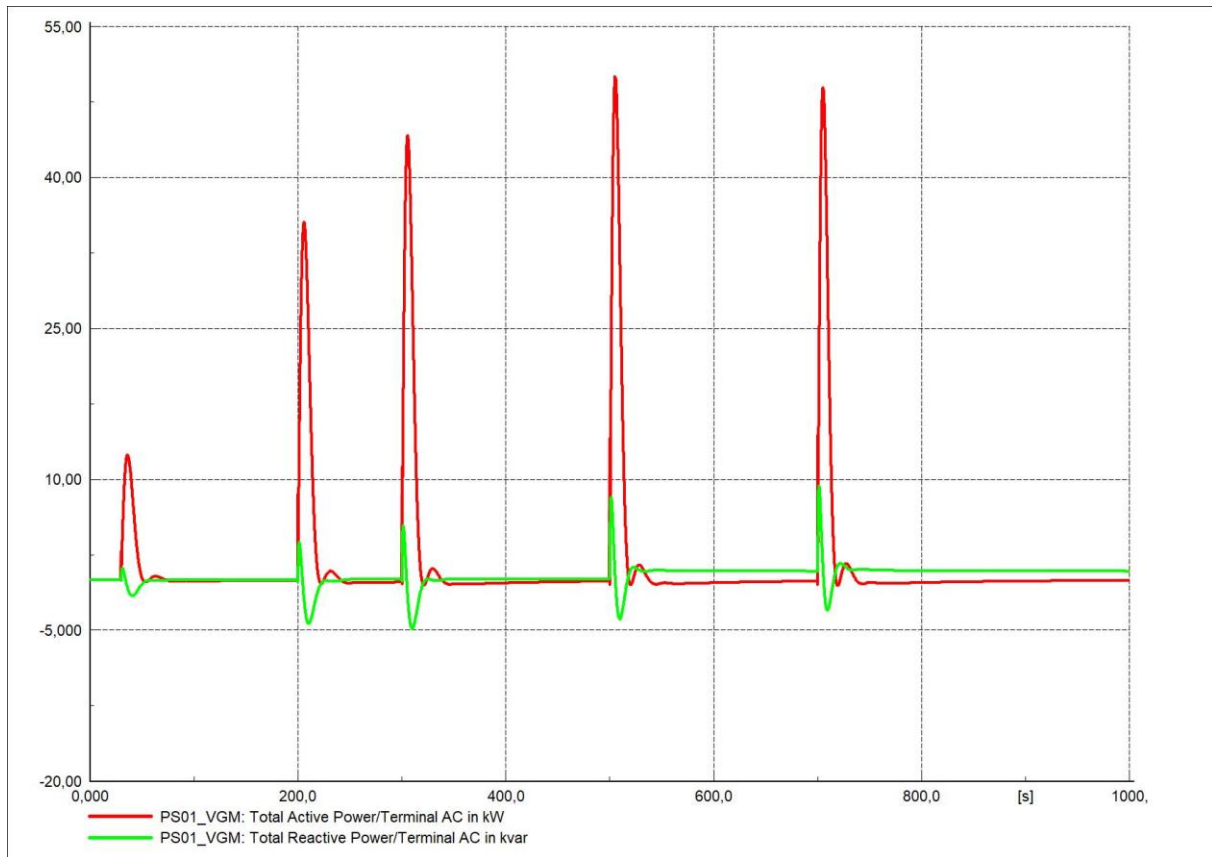

Figure 23 Ludvika; BESS power

### 5.3. Disconnection of loads

The process of disconnection of loads are evaluated to see how the system is affected by such events. The simulations were conducted in the same way as when connecting loads, with the same parameters and the loads disconnection order ranging from smallest to largest. When the loads are disconnected instead of connected, the BESS needs to absorb the active power from the loads.

The result, which can be found in Appendix D, showed a similar behaviour regarding the deviation of voltage and frequency. The deviation does not exceed the allowances of  $\pm 1$  Hz and  $\pm 10\%$  with BESS for both scenarios in Ålem. As for the Ludvika scenario including the BESS, the frequency deviation exceeds the range of  $\pm 1$  Hz. In contrast to the simulation of connection of loads, the second load disconnection of 150 kW does not exceed the frequency range. Another difference is that the runner blade opening is negative when disconnecting the last load of 250 kW. As mentioned earlier, this is not reasonable and might occur because of the combination curve. This is, however, not evaluated in more detail.

## 6 DISCUSSION

To answer the research questions, the following part is evaluated and discussed; construction of the models, simulations and results and finally economic and social aspects.

### 6.1. Model construction

By comparing the model built in PowerFactory to the reference model in Simulink the performance of the model was quality assured. It could even be improved and thereby attaining a better initialisation condition. A problem with the model was to simulate the start of the operation. The initial aim was that the Ålem model should not have any loads connected at start-up. It turned out to be impossible to simulate the model without a power demand. As for Ludvika, there should be some loads connected at simulation start, but the same problem occurred for the Ludvika simulation as well, the power demand was too low. Consequently, base loads were introduced so that the initial power demand would be higher. When analysing the reason for this problem, it originated from the index curves and the combination curve of the turbine models. When simulating without the base loads, the runner blade opening after initiation was negative, which is not reasonable. If seeing to the combination curve for Ludvika, the runner blade opening begins at zero while the wicket gate opening is around 26 %. The output of this combination results in too high power in relation to the desired power demand. Thus, the wicket gate opening is reduced, resulting in a negative opening for the runner blade. Another reason is due to the curve fitting, which is based on measured index points from the Ludvika power plant. The index curve begins with an attained power output of 1.5 MW and the power output from the simulation before adding the base load is 0.146 MW. This results in some uncertainties and that the model simulates values which lie outside of the input data and cannot be seen as reliable. At the start of an island mode operation, it might be necessary to tune in the model before the right combination curve has been reached.

When applying regulation by runner blade, the wicket gate opening is fixed at a selected value. Choosing a too high runner blade opening makes it impossible to attain low power output. A value that is too low limits the possible power output. When the desired power output is known it is possible to choose a wicket gate opening that gives the desired output. Before the simulation, the wicket gate opening was decided by calculating the power output in Excel. By testing different wicket gate openings, the power output was plotted to choose a reasonable wicket gate opening that is not too high and not too low.

Furthermore, the model is supposed to represent how turbines and generators work. However, it is a simplification and does not contain each mechanical component and does not consider water flow to the turbines. Consequently, there is room for improving the model.

## 6.2. Simulation and result

For this study, the frequency is set to not exceed  $\pm 1$  Hz from the setpoint which is 50 Hz. The simulated result shows that the frequency deviation for the Ålem case can be kept within the given range when a BESS is included in the MG. It is regardless of which type of frequency control that is utilized for the hydropower. However, the result shows that by applying frequency control by means of runner blade, the frequency deviation can be reduced slightly, and it returns to setpoint faster compared to frequency control by means of wicket gate. Wicket gate regulation is dependent on the combination curve, thereby giving a higher efficiency compared to runner blade regulation. This is because the opening of the runner blade is decided based on the wicket gate opening to give the best efficiency. However, the main objective of this study is to optimize the control of frequency. The efficiency for the hydropower plant is therefore not analysed more in-depth.

The frequency was not kept within the  $\pm 1$  Hz limit for none of the Ludvika simulations nor the Ålem cases without a BESS. The power plant in Ludvika has a faster regulation of wicket gates and runner blades compared to the Ålem hydropower. Despite this, the frequency control in Ludvika is not able to keep the frequency within the given bounds. The results show that the control of the frequency is fast as the frequency returns to setpoint rapidly. However, it does not help the peak point at where the frequency deviate.

The allowance for frequency deviation is set to  $\pm 1$  Hz as this is defined by a previous study at SWECO. Compared to the allowed deviation defined by SVK at  $\pm 0.1$  Hz for normal network condition the allowance is large. Despite this, it might be possible to increase the allowed frequency deviation to  $\pm 2$  Hz. This would result in the simulated result for Ludvika being within an acceptable range. However, it would need to be analysed further to prevent any faults in the MG that could be caused by a too large deviation in frequency. Moreover, adjusting any relays that are set to release at a deviation in frequency.

The primary conditions for the simulations of the two MGs, the one in Ålem and the one in Ludvika, are not the same. Both the size of the generator and the loads differ a lot. Ludvika has a generator power of 4100 kVA, whereas the generator power in Ålem is 700 kVA. The size of the battery is adjusted according to the Ludvika MG, indicating that it might be oversized in the Ålem MG. The large difference in the generators when having the same size for the battery can be a reason for the different results. Another reason might be the large difference in load connections. The loads that are connected in Ålem is a lot smaller compared to the ones in Ludvika. The largest load that is connected in Ålem is 28.2 kW, whereas the smallest load that is connected in Ludvika is 50 kW. The second load that is connected in Ludvika is 150 kW. Seeing to the result, the generator can regulate the frequency for a load connection of 50 kW, the load connection of 150 kW is on the contrary too large for the generator to regulate and keep the frequency within the  $\pm 1$  Hz deviation. By dividing the loads and thereby reducing the loads which are connected at one time it would be possible to maintain the frequency within given bounds.

During the simulation, an adaption of the hydropower plant control parameters was made to obtain a reasonable behaviour of the frequency control. The parameters for the PID-controllers were adapted to fit the system without the BESS included. When including the

BESS, the parameters were kept the same so that the results could be comparable. As Ålem does not have control of frequency there is no data for the PID-controller. These values had to be estimated, the aim was to attain the fastest possible regulation without jeopardising the stability of the system. The result of the Ålem simulation showed that the return time before the frequency reached setpoint was long and that the time could be reduced by increasing the  $K_i$  parameter for the PID-controller governing the frequency. The frequency droop was reduced when simulating the result for the runner blade regulation. Consequently, reducing the frequency peak deviation and increasing the rate of return before the frequency reaches set point. Despite the reduced frequency droop, the runner blade regulation had a higher rate of return compared to the wicket gate regulation.

Different frequency droops for the BESS was tested in the Ludvika simulation, it showed a small improvement in frequency deviation. However, the lower value did not manage to reduce the frequency deviation as much as required. Therefore, the default values for the BESS was kept. The powerplant in Ludvika is prepared for operation in island mode as it contains control of frequency through wicket gate. Parameters for the PID-controller was thereby attained from the operator, though it was known that the parameters for the frequency regulator for island operation were not tuned in as the island operation has never been tested. However, it was not possible to run the simulation without adjusting the parameters of the PID-controller for the wicket gate. The PID-parameters utilized for the simulation are presented in Appendix B.

As for the voltage, it is controlled by the hydropower as there is no direct control of voltage by the BESS. It is still monitored to ensure the stability of the MGs. As the allowed deviation of voltage is 10% both MGs are within the acceptable range and are not near the limit. The result from the Ludvika simulation showed that one location in the electricity network was lower than the other measured nodes. The fact that it is located furthest away from the generator is a probable reason for the deviation. However, it reaches 0.95 p.u. which is well within the limit of 0.9 p.u..

### **6.3. Control strategy**

Both the Ålem MG and the Ludvika MG applies master-slave control strategy. Due to the difference in capacity, the hydropower is set as the reference machine in the MG. It is set to have constant voltage control and the BESS takes on PQ control, thereby keeping the reactive and active power constant. Furthermore, the operation follows the hierarchy control strategy. First, the voltage is regulated, secondly, droop control is applied to fix the mismatch of frequency.

## 6.4. Social and economic aspects

In this study, social and economic aspects have not been analysed. Before starting the projecting of a BESS included in a MG operated in island mode these must be considered more in-depth.

The possibility to operate a MG in island mode can provide independency for municipalities, and the ability to deliver electricity at all times. Even though the national grid is stable, and it is unusual with major events, unforeseen events can occur. Islanded operation would not be an often-occurring event. However, if and when a large fault in the national grid occurs, the ability to be able to provide electricity to the residents would be invaluable. Thus, it is still a large investment and it is, therefore, a good idea to make sure that the BESS can be utilized for other applications. There is no such plan in place in Ålem, which, therefore, needs to be defined. For example, it can support the daily operation by providing ancillary services to the national grid. It can also work as a storage system so that energy produced by for example PV panels can be stored and used when needed. It is known that the BESS in Ludvika works as an uninterrupted power supply (UPS) and can provide power at shorter power interruptions in the grid. Diesel generators are commonly used as UPS today, which is the case in Ludvika. By replacing diesel generators with BESS, emission of CO<sub>2</sub> can be reduced.

Cost for batteries is expected to decrease rapidly, up to 80% by 2050, making them low-cost alternatives for energy storage. Reduction in cost consequently elevates the accessibility globally. A challenge that can be taken into consideration and analysed more in-depth as it can impact the development, is the relatively low electricity price in Sweden. It can prohibit investments in new technology within the field of electric power and network. Further evaluations regarding the economy of a BESS can be conducted after this study and should define the application for the BESS as this affects the LCOS.

## 7 CONCLUSIONS

The BESS provides stability to the MG by reducing the frequency deviation at load changes. By optimizing the parameters for the PID-controller according to the island mode, the best possible regulation can be attained. Adaption of the frequency droop parameter for the BESS can improve the control of frequency by decreasing the peak deviation or reducing the return time. The droop parameter is an index on how much active power the BESS should provide. Setting the droop too low would result in the BESS running low on power and the generator decreasing in speed, leading to high return time for the frequency to setpoint. If the frequency droop would be too high, the BESS would provide too little active power which could lead to a frequency deviation exceeding the given bounds. A hydropower plant that has slow control of frequency by wicket gate and runner blade can attain faster regulation with a BESS. The voltage control is improved by the BESS, leading to reduced variation in voltage at load changes.

Due to the large difference in capacity between the generator and BESS, the hydropower is set as a reference machine by constant voltage control. Thus, the system applies the Master-slave control strategy, the hydropower is the master unit, while the BESS is a slave unit. The BESS takes on PQ control and regulates the reactive and active power, hence, regulating the frequency by droop control.

The BESS needs to be sized according to the loads that are connected and the generator capacity. A larger BESS can provide more power but will be more expensive. Accordingly, cost can be optimized.

Predictions on price development for BESS show a decreasing trend. Reduced cost will consequently enable utilization of BESS globally. Application of MG operated in island mode provides self-sufficiency for municipalities. By enabling the possibility to operate an isolated MG, electricity can be delivered at all times. Thus, securing the supply of freshwater, heat and other viable functions in society. As BESS does not emit any greenhouse gases, they indirectly reduce emission of CO<sub>2</sub>. Both because they replace diesel generators and as they can store energy produced by RES.

## **8 SUGGESTIONS FOR FURTHER WORK**

With further studies, it is possible to attain an even more representative model of the hydropower plant. That is, a model that characterises the mechanical behaviour of a hydropower.

Moreover, additional analysis of load connection can be conducted for Ludvika to evaluate the possibility to attain a frequency deviation within the  $\pm 1$  Hz limit. The possibilities to divide larger loads can be investigated as well. Additional tuning of the PID-parameters could be conducted to optimize the operation of the MGs in island mode. There are many parameters for the BESS that can be adjusted and possibly attain improved control of frequency and voltage.

Preferably, a live test of the island mode operation would be conducted in Ludvika. If so, the parameters for the PID-controllers could be attained. This test should also include the start-up conditions so that lower values for the index curve could be attained.

Lastly, an extensive economic evaluation could give a good forecast on economic viability for a BESS. An economic evaluation should include sizing of the system and define what applications it can be utilized for.

## REFERENCES

- Aghamohammadi, M. R., & Abdolahinia, H. (2014). A new approach for optimal sizing of battery energy storage system for primary frequency control of islanded Microgrid. *International Journal of Electrical Power & Energy Systems*, *54*, 325–333.  
<https://doi.org/10.1016/j.ijepes.2013.07.005>
- Ålem Energi. (n.d.). Elnät—Ålem Energi. Retrieved 26 May 2020, from <https://www.alemenergi.se/Din-lokala-ellevererantoer/Elnaet>
- Bergström, O., & Ayaad, A.-E. (2011). *Utvärdering av vattenkraft: Turbin med variabelt varvtal*. 59.
- Breeze, P. (2018). *Power System Energy Storage Technologies*. Retrieved from <http://ebookcentral.proquest.com/lib/malardalen-ebooks/detail.action?docID=5399303>
- British Electricity International. (1991). Turbines, Generators and Associated Plant (Third Edition). In *Turbines, Generators and Associated Plant (Third Edition)* (pp. 422–445). <https://doi.org/10.1016/B978-0-08-040513-1.50013-0>
- Cagnano, A., De Tuglie, E., & Mancarella, P. (2020). Microgrids: Overview and guidelines for practical implementations and operation. *Applied Energy*, *258*, 114039.  
<https://doi.org/10.1016/j.apenergy.2019.114039>
- Ciez, R. E., & Steingart, D. (2020). Asymptotic Cost Analysis of Intercalation Lithium-Ion Systems for Multi-hour Duration Energy Storage. *Joule*, *4*(3), 597–614.  
<https://doi.org/10.1016/j.joule.2020.01.007>
- Cole, W. J., & Frazier, A. (2019). *Cost Projections for Utility-Scale Battery Storage* (No. NREL/TP-6A20-73222, 1529218; p. NREL/TP-6A20-73222, 1529218).  
<https://doi.org/10.2172/1529218>
- DIgSILENT. (n.d.-a). Company—DIgSILENT. Retrieved 5 February 2020, from <https://www.digsilent.de/en/company.html>
- DIgSILENT. (n.d.-b). PowerFactory—DIgSILENT. Retrieved 5 February 2020, from <https://www.digsilent.de/en/powerfactory.html>

- Energimyndigheten. (2020). Effektbrist. Retrieved 4 February 2020, from <https://www.energimyndigheten.se/trygg-energiforsorjning/el/effektbrist/styrel/effektbrist/>
- Engineers, W. svg; U. S. A. C. of. (2011). *English: Hydraulic turbine and electrical generator, cutaway view*. Retrieved from [https://commons.wikimedia.org/wiki/File:Water\\_turbine\\_\(en\).svg](https://commons.wikimedia.org/wiki/File:Water_turbine_(en).svg)
- Forsling, G., & Rasouli, A. (2017). *Prioriterad kraftmatning i Ludvika*. SWECO ENERGY.
- Forum för smarta elnät. (n.d.). Elsystemet förnyas. Retrieved 14 February 2020, from <http://swedishsmartgrid.se/varfor-smarta-elnet/elssystemet-fornyas/>
- Fredriksson, J. (2019). *Anpassning av småskaliga vattenkraftverk för ö-drift av lokalt elnät*. Retrieved from <http://urn.kb.se/resolve?urn=urn:nbn:se:uu:diva-388143>
- Ganji, M., & Shahidehpour, M. (2018). 5—Development of a residential microgrid using home energy management systems. In L. A. Lamont & A. Sayigh (Eds.), *Application of Smart Grid Technologies* (pp. 173–192). <https://doi.org/10.1016/B978-0-12-803128-5.00005-2>
- Gao, D. W. (2015). *Energy Storage for Sustainable Microgrid*. Retrieved from <http://ebookcentral.proquest.com/lib/malardalen-ebooks/detail.action?docID=2110664>
- Gustafsson, M. (2013). *Improved Governing of Kaplan Turbine Hydropower Plants Operating Island Grids*. 57.
- Hajiakbari Fini, M., & Hamedani Golshan, M. E. (2018). Determining optimal virtual inertia and frequency control parameters to preserve the frequency stability in islanded microgrids with high penetration of renewables. *Electric Power Systems Research*, 154, 13–22. <https://doi.org/10.1016/j.epsr.2017.08.007>
- Jones, L. E. (2014). *Renewable Energy Integration: Practical Management of Variability, Uncertainty, and Flexibility in Power Grids*. Retrieved from <http://ebookcentral.proquest.com/lib/malardalen-ebooks/detail.action?docID=1711470>

- Khodadoost Arani, A. A., B. Gharehpetian, G., & Abedi, M. (2019). Review on Energy Storage Systems Control Methods in Microgrids. *International Journal of Electrical Power & Energy Systems*, 107, 745–757. <https://doi.org/10.1016/j.ijepes.2018.12.040>
- MSB. (2019a). Samhällets ansvar vid strömavbrott. Retrieved 28 January 2020, from <https://www.krisinformation.se/detta-kan-handa/stromavbrott-ny/samhallets-ansvar-vid-stromavbrott>
- MSB. (2019b). Strömavbrott. Retrieved 27 January 2020, from <https://www.krisinformation.se/detta-kan-handa/stromavbrott-ny>
- Nordling, A. (2016). *Sveriges framtida elnät* (No. ISBN: 978-91-7082-911-6; p. 56). IVA.
- Olivares, D. E., Mehrizi-Sani, A., Etemadi, A. H., Cañizares, C. A., Iravani, R., Kazerani, M., ... Hatziargyriou, N. D. (2014). Trends in Microgrid Control. *IEEE Transactions on Smart Grid*, 5(4), 1905–1919. <https://doi.org/10.1109/TSG.2013.2295514>
- Samanta, S., Mishra, J. P., & Roy, B. K. (2019). Implementation of a virtual inertia control for inertia enhancement of a DC microgrid under both grid connected and isolated operation. *Computers & Electrical Engineering*, 76, 283–298. <https://doi.org/10.1016/j.compeleceng.2019.04.006>
- Schmidt, O., Melchior, S., Hawkes, A., & Staffell, I. (2019). Projecting the Future Levelized Cost of Electricity Storage Technologies. *Joule*, 3(1), 81–100. <https://doi.org/10.1016/j.joule.2018.12.008>
- Speychal, M. (2019). *STABILITETSTUDIE AVSEENDE FREKVENNS- OCH SPÄNNINGSSTABILITET FÖR EN ÖDRIFTSITUATION MED ENERGILAGER* (No. R19-01-SESPEY). SWECO ENERGY.
- SVK. (2019). Drift och elmarknad. Retrieved 4 February 2020, from <https://www.svk.se/drift-av-stamnatet/drift-och-elmarknad/>
- SVK. (2020). Kontrollrummet. Retrieved 4 February 2020, from <https://www.svk.se/drift-av-stamnatet/kontrollrummet/>
- Tesarova, M., & Nohac, K. (2014). Voltage and frequency stability analysis of an island-mode LV distribution network. *Proceedings of the 2014 15th International Scientific*

*Conference on Electric Power Engineering (EPE)*, 137–142.

<https://doi.org/10.1109/EPE.2014.6839460>

Urquizo, A. (2011). *English: PID controller overview*. Retrieved from

[https://commons.wikimedia.org/wiki/File:PID\\_en.svg](https://commons.wikimedia.org/wiki/File:PID_en.svg)

Vahidi, B., Jazebi, S., & Naghizadeh, R. A. (2012). Modeling Hydro Power Plants and Tuning Hydro Governors as an Educational Guideline. Retrieved 9 June 2020, from

ResearchGate website:

[https://www.researchgate.net/publication/235675537\\_Modeling\\_Hydro\\_Power\\_Plants\\_and\\_Tuning\\_Hydro\\_Governors\\_as\\_an\\_Educational\\_Guideline](https://www.researchgate.net/publication/235675537_Modeling_Hydro_Power_Plants_and_Tuning_Hydro_Governors_as_an_Educational_Guideline)

VB Energi. (n.d.). VB Elnät. Retrieved 23 April 2020, from VB Energi website:

<https://www.vbenergi.se/om-oss/foretagsstruktur/vb-elnat/>

Zachariasson, H. (2019, October 25). Samarbete ska trygga elbehov. *SVT Nyheter*. Retrieved from <https://www.svt.se/nyheter/lokalt/stockholm/samarbete-ska-trygga-elbehov>

# APPENDIX A: MODEL

This section includes schemes over some of the models in PowerFactory.

## TURBINE

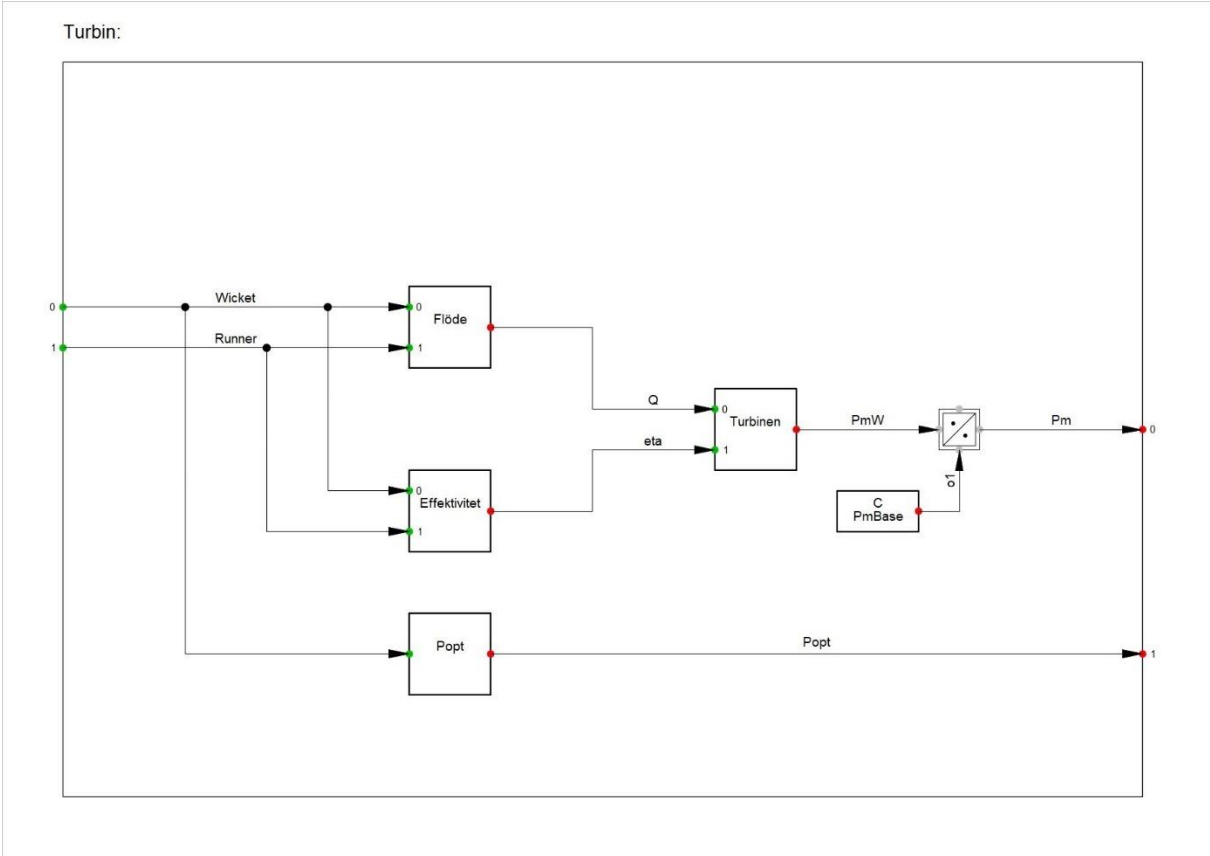

## GENERATOR

Frame-Ledskenereglering-Generator:

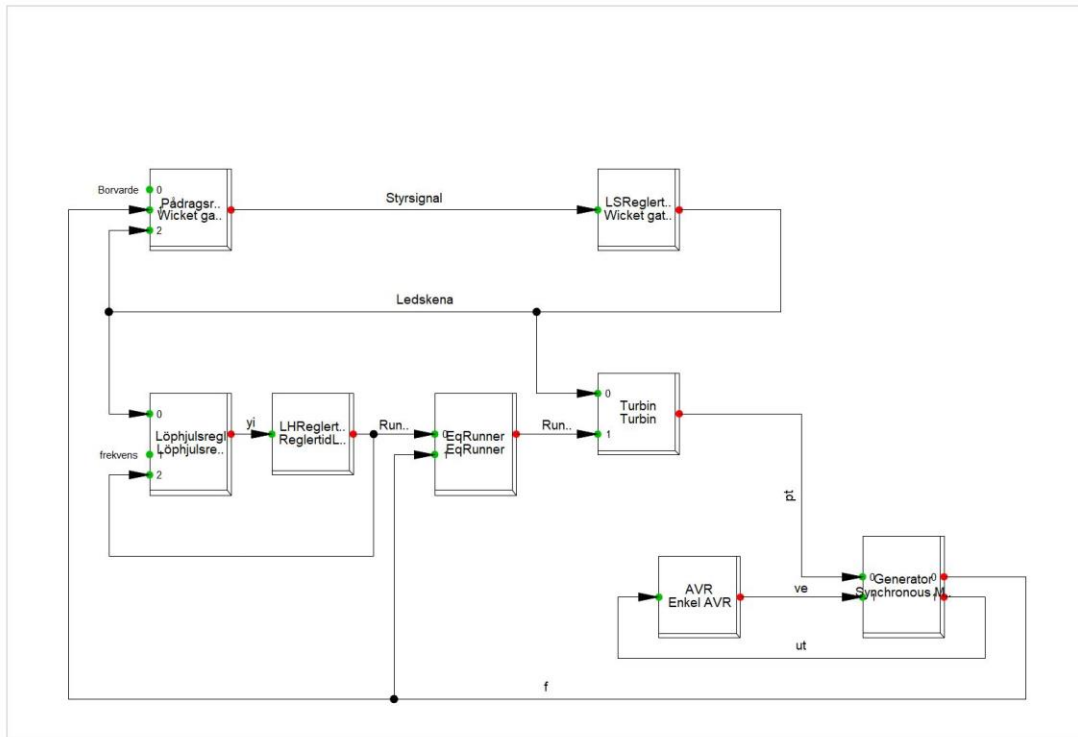

## COMBINATION – RUNNER BLADE AND WICKET GATE

LøphjulsreglKomb\_PID:

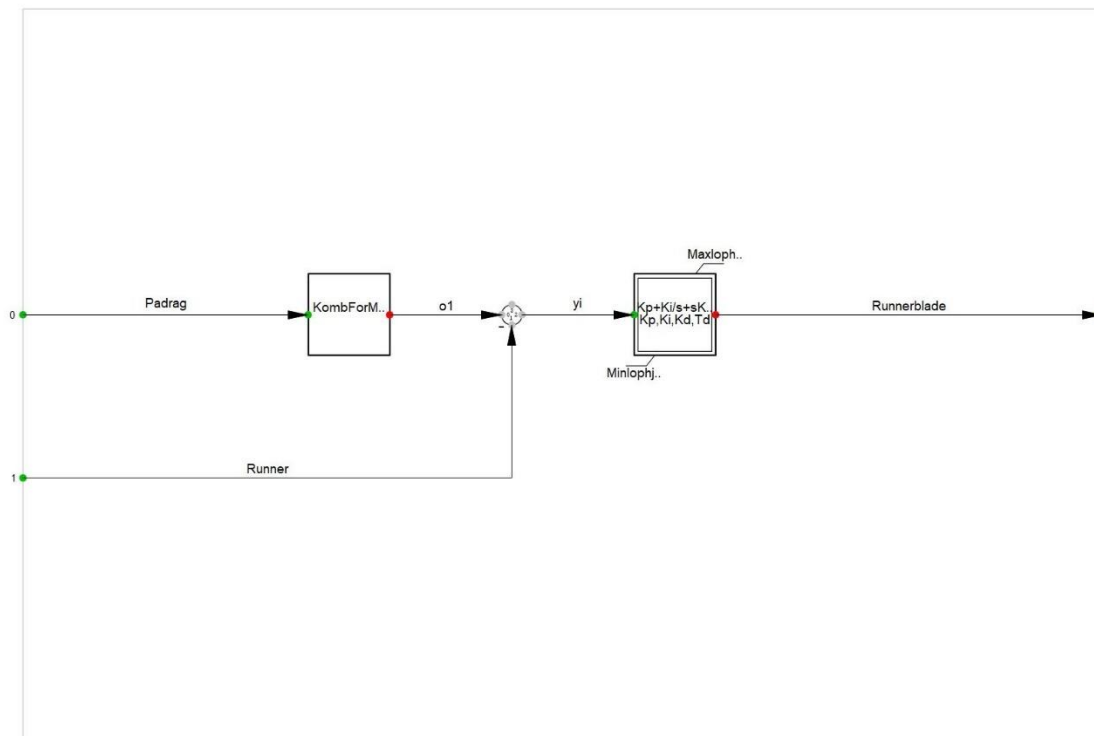

# COMBINATION – RUNNER BLADE

LöphjulsreglKomb:

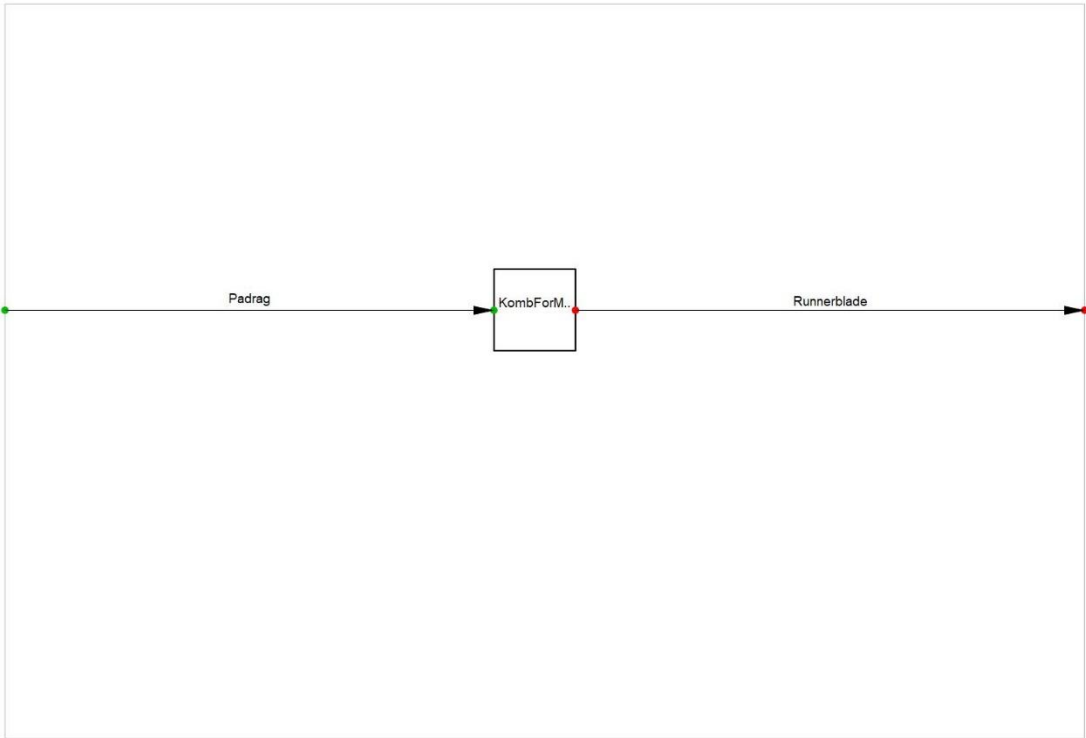

# LUDVIKA: FREQUENCY CONTROL – WICKET GATE

Ledskenereglering+freglering:

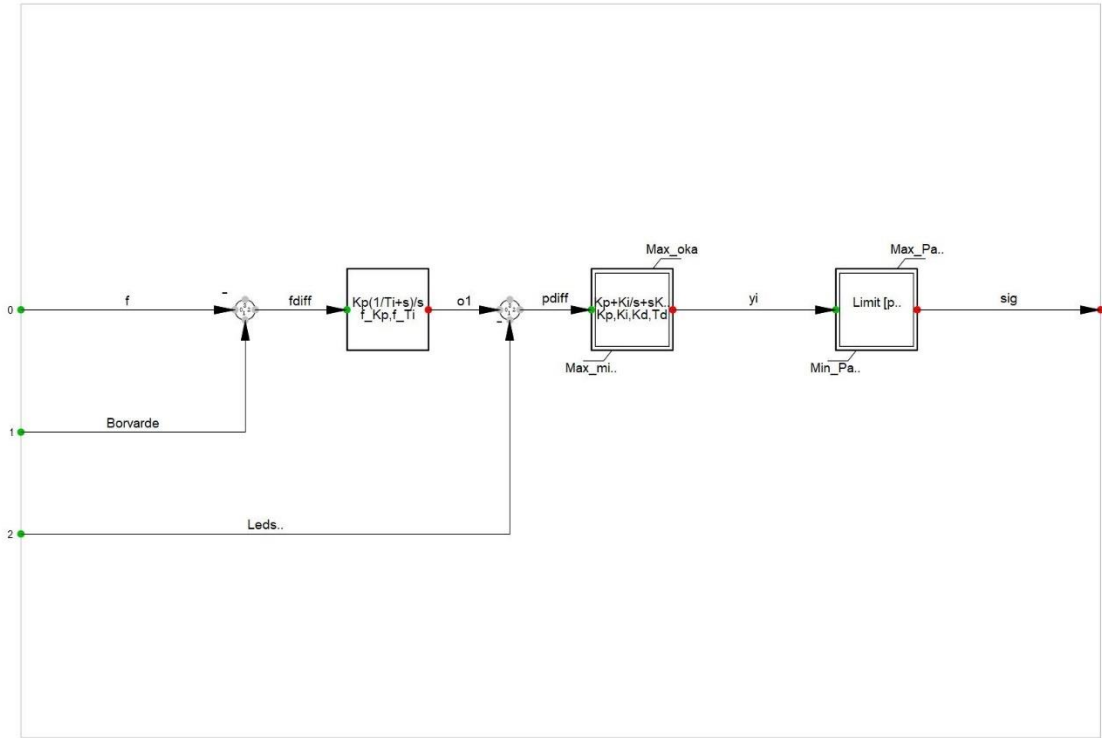

## ÅLEM: FREQUENCY CONTROL – WICKET GATE

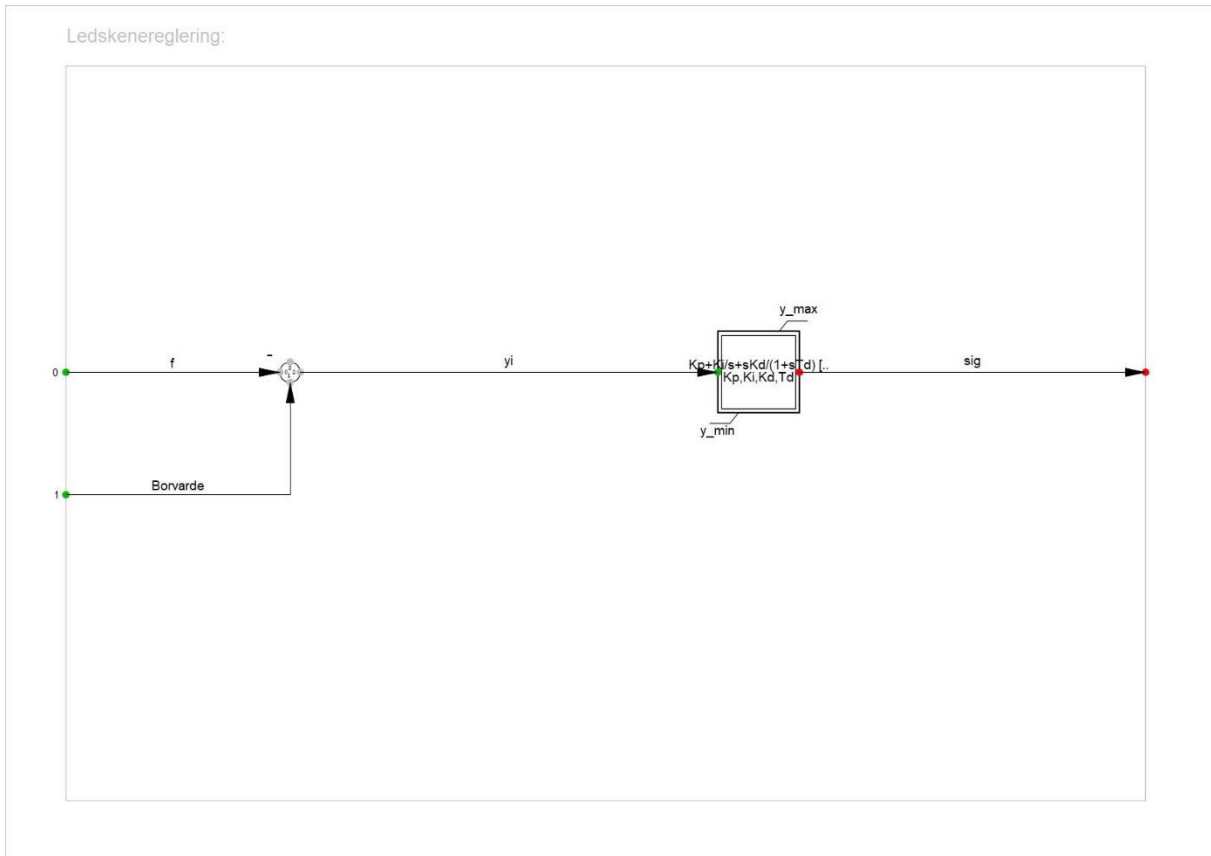

## ÅLEM: FREQUENCY CONTROL – RUNNER BLADE

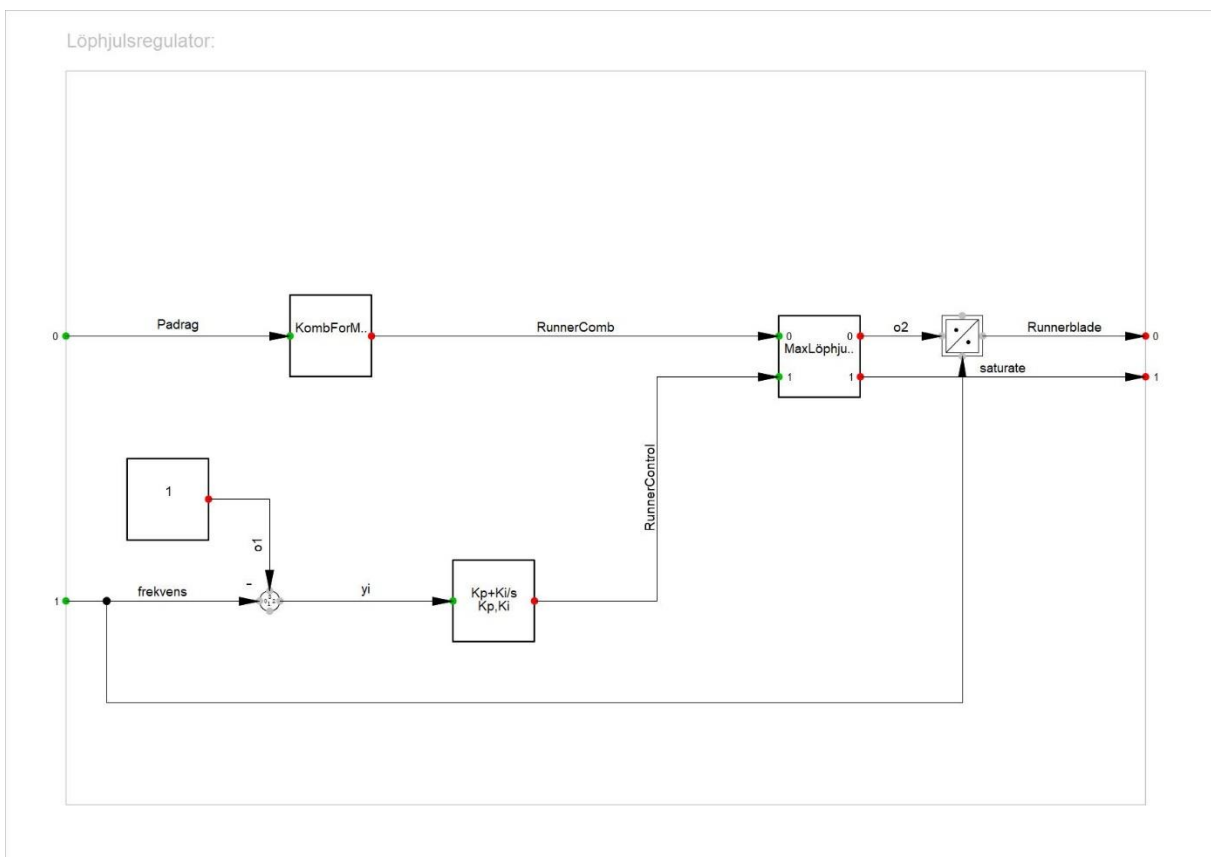

## APPENDIX B: PID-parameters

The first column in the table shows the given parameters for the PID-parameters for the Ludvika system. Some of these parameters needed to be adjusted to attain a stable system, the parameters utilized in the simulation is seen in the second column.

<b>Ludvika PID-parameters</b>			
<b>Given</b>		<b>Simulated</b>	
<b>Wicket gate regulation</b>			
<b>Kp</b>	5	<b>Kp</b>	1
<b>Ti</b>	20 s	<b>Ki</b>	15
<b>Td</b>	5 s	<b>Kd</b>	0.1
<b>Kd</b>	Not given	<b>Td</b>	5
<b>Max decrease signal</b>	-90%	<b>Max decrease signal</b>	-90%
<b>Min increase signal</b>	90%	<b>Min increase signal</b>	90%
<b>Runner blade regulation</b>			
<b>Kp</b>	5	<b>Kp</b>	5
<b>Ti</b>	20 s	<b>Ki</b>	0.05
<b>Td</b>	0 s	<b>Kd</b>	0
<b>Kd</b>	Not given	<b>Td</b>	1
<b>Max runner blade limitation</b>	-1%	<b>Max runner blade limitation</b>	-1%
<b>Min runner blade limitation</b>	98%	<b>Min runner blade limitation</b>	98%
<b>Island mode</b>			
<b>Kp</b>	80	<b>Kp</b>	2
<b>Ki</b>	3	<b>Ki</b>	25

The PID-parameters for Ålem is not known and therefore, only the PID-parameters from the simulation are presented.

<b>Ålem PID-parameters</b>	
<b>Wicket gate regulation</b>	
<b>Kp</b>	60
<b>Ki</b>	3
<b>Kd</b>	0
<b>Td</b>	1
<b>Max decrease signal</b>	0
<b>Min increase signal</b>	250
<b>Runner blade regulation</b>	
<b>Kp</b>	10
<b>Ki</b>	5

## APPENDIX C: Generator data

Generator parameters for time constants and reactances for Ålem are presented in the table. As it is unclear if the parameters used in the Ludvika simulation are allowed to be shared, these are not included in the paper.

---

<b>Ålem Generator parameters</b>	
<b>Stator parameters</b>	
<b>rstr</b>	0.017 p.u.
<b>xl</b>	0.04 p.u.
<b>Synchronous reactances</b>	
<b>xd</b>	1.561 p.u.
<b>xq</b>	1.408 p.u.
<b>Transient reactances</b>	
<b>xd'</b>	0.27 p.u.
<b>Subtransient reactances</b>	
<b>xd''</b>	0.213 p.u.
<b>xq''</b>	0.487 p.u.
<b>Transient time constants</b>	
<b>Td'</b>	0.137 s
<b>Subtransient time constants</b>	
<b>Td''</b>	0.025 s
<b>Tq''</b>	0.011 s

---

# APPENDIX D: Result – Disconnection of loads

This section presents the result for the simulation were leads were disconnected. The same types of diagrams are presented here as in the result section.

## ÅLEM RUNNER BLADE

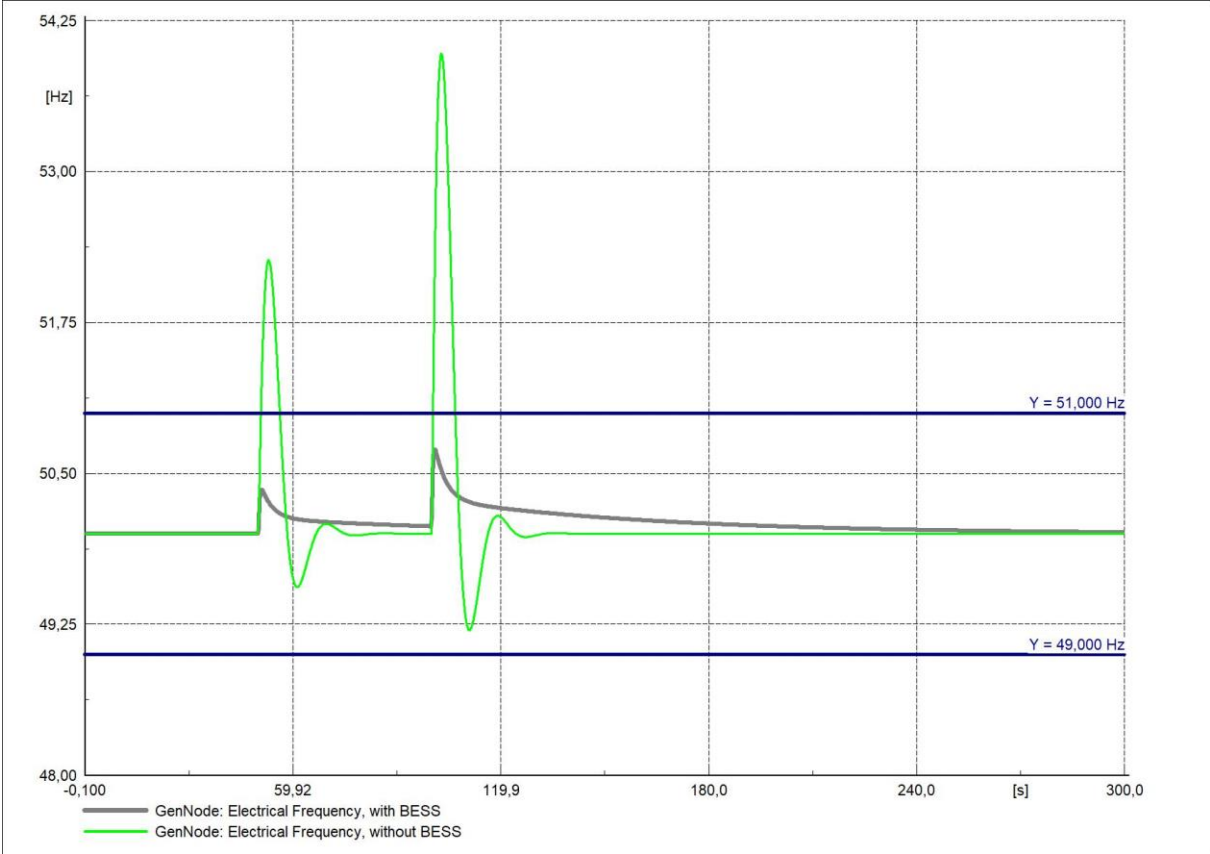

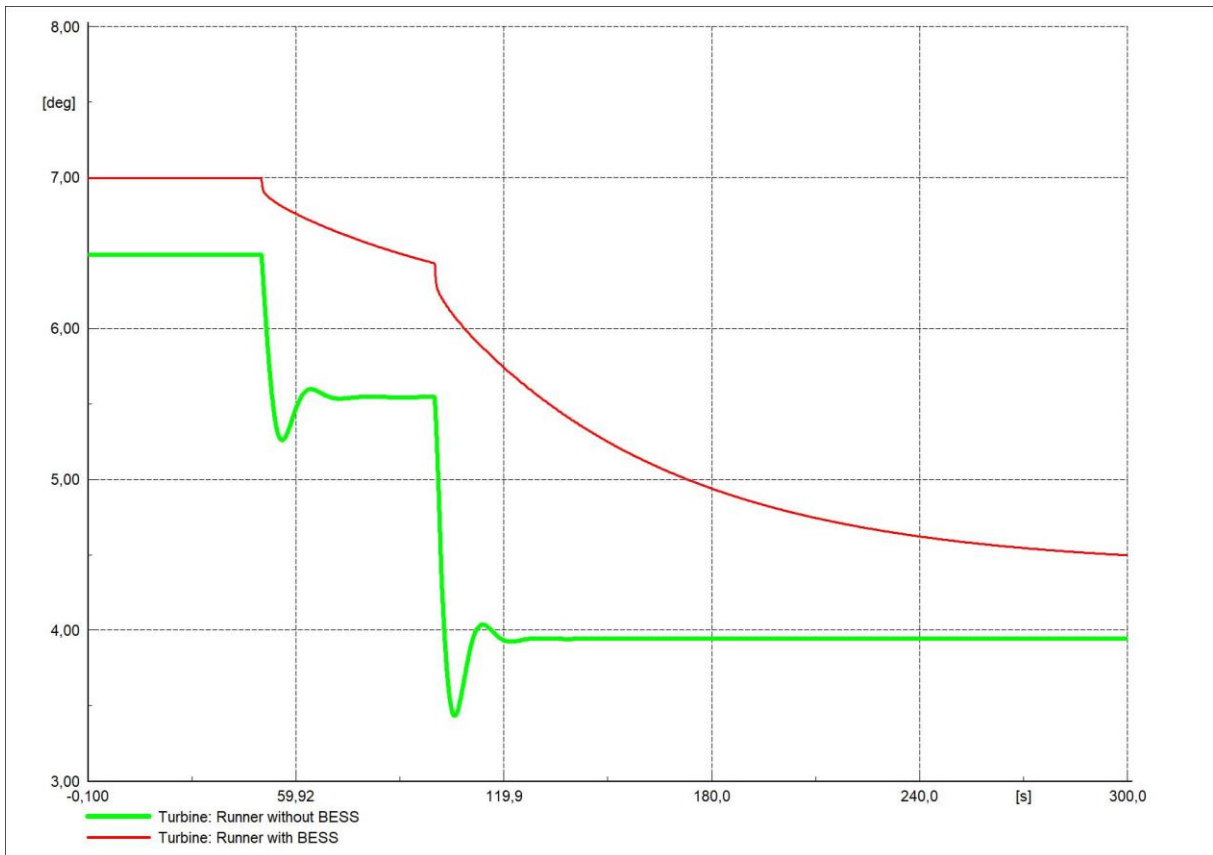
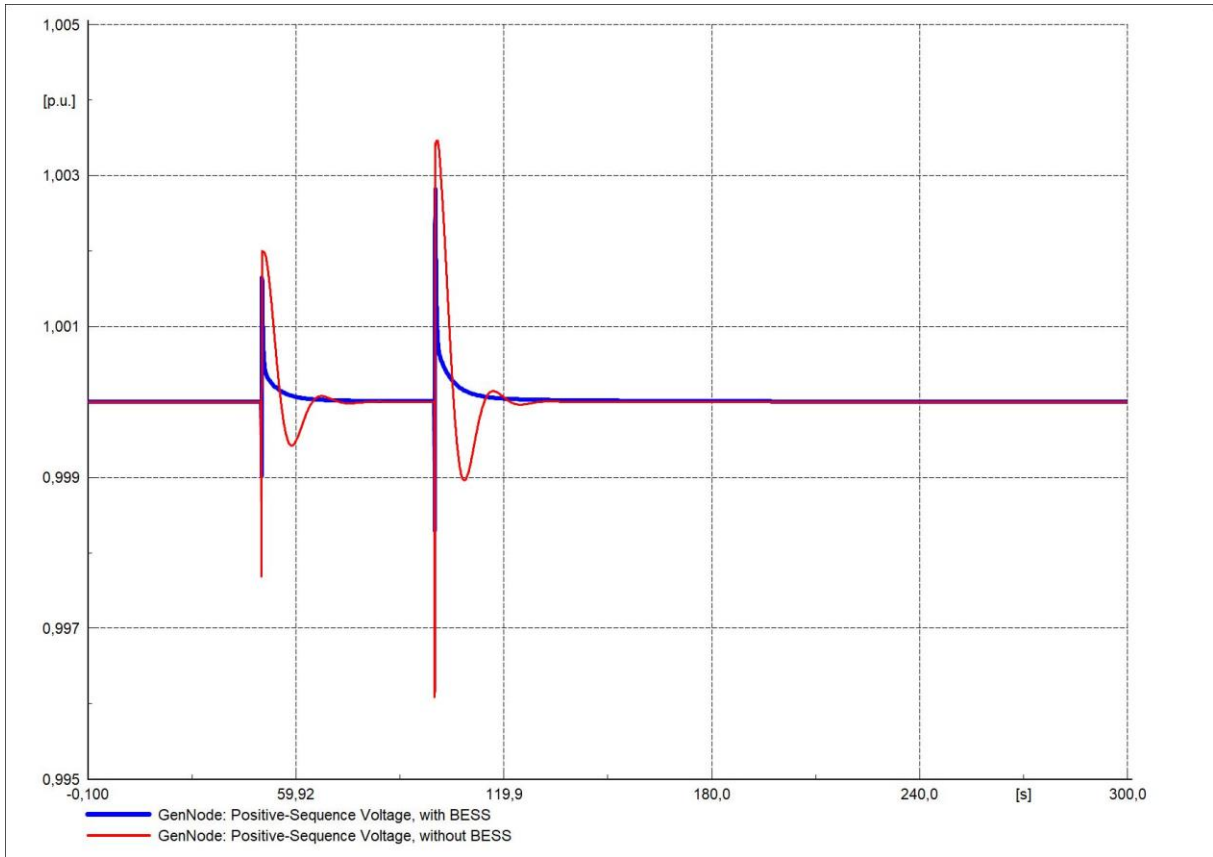

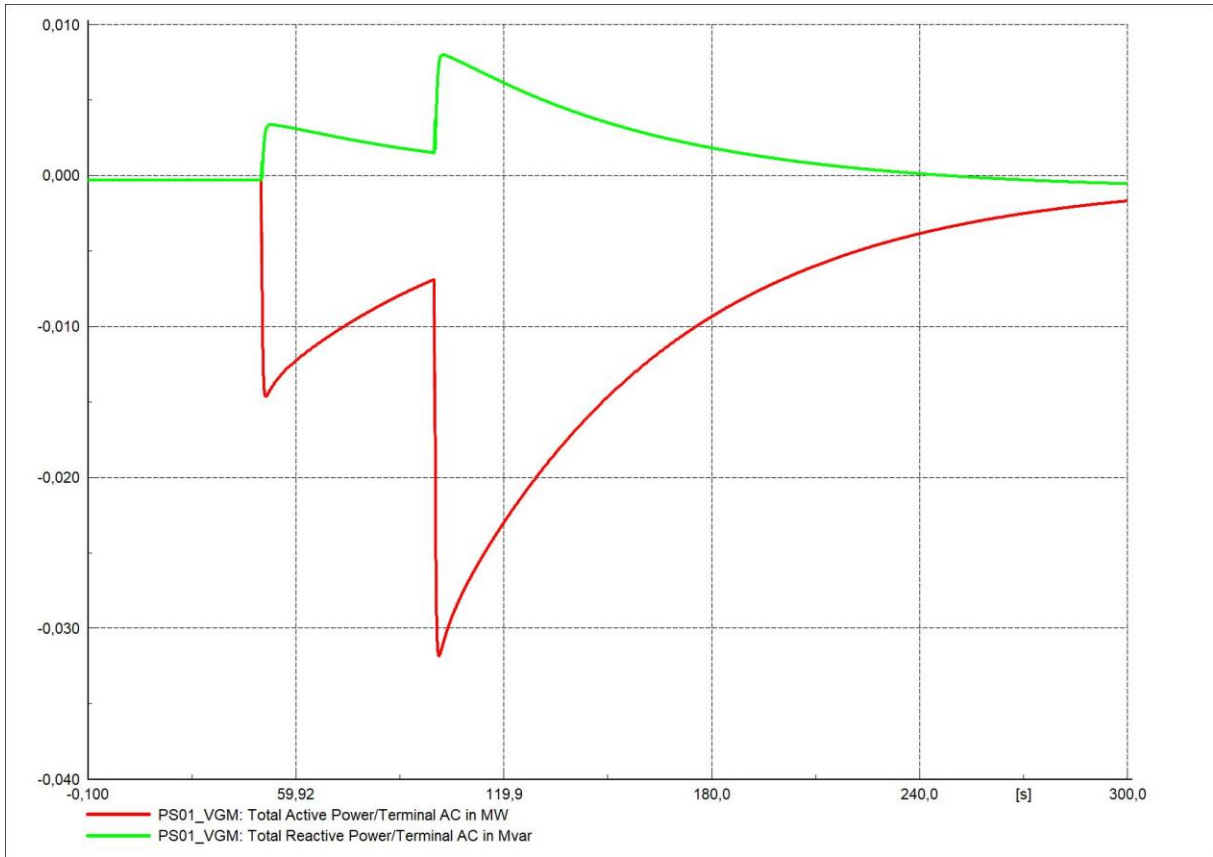

## ÅLEM WICKET GATE

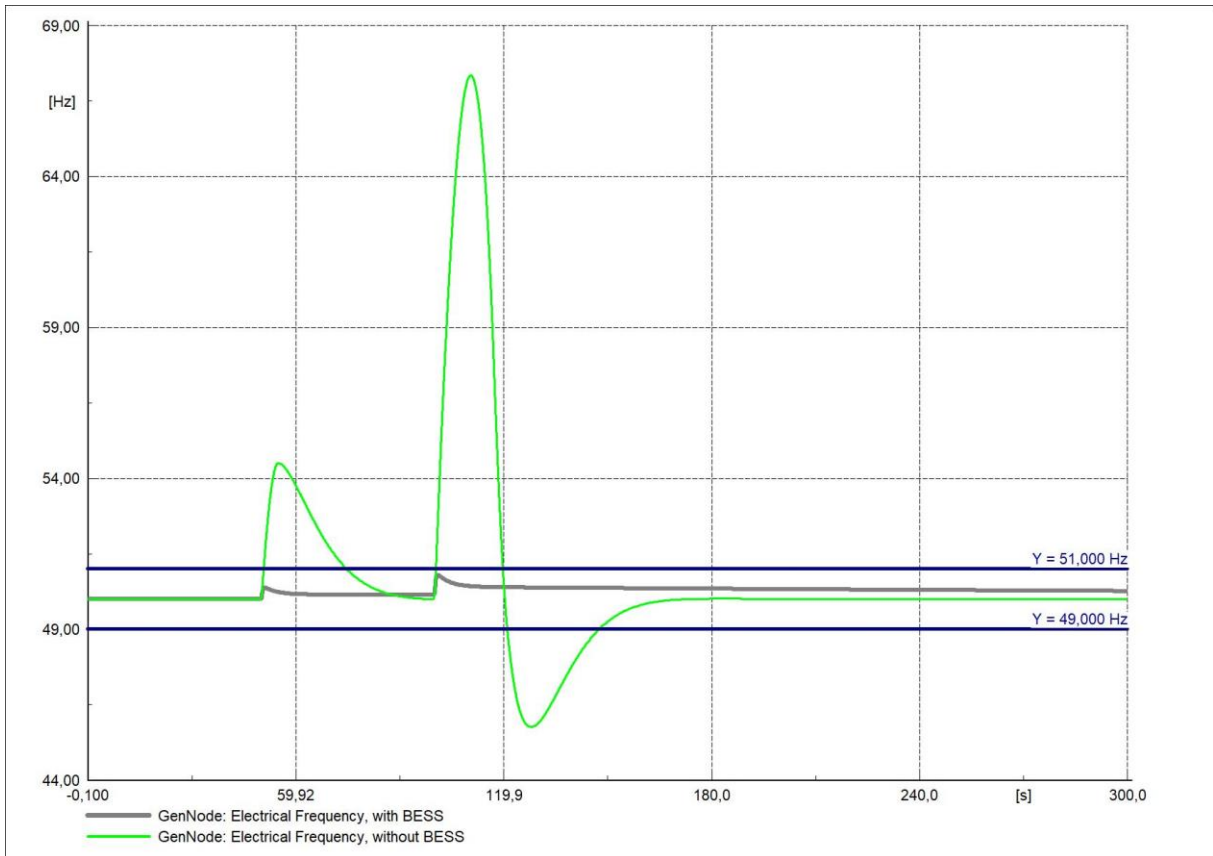

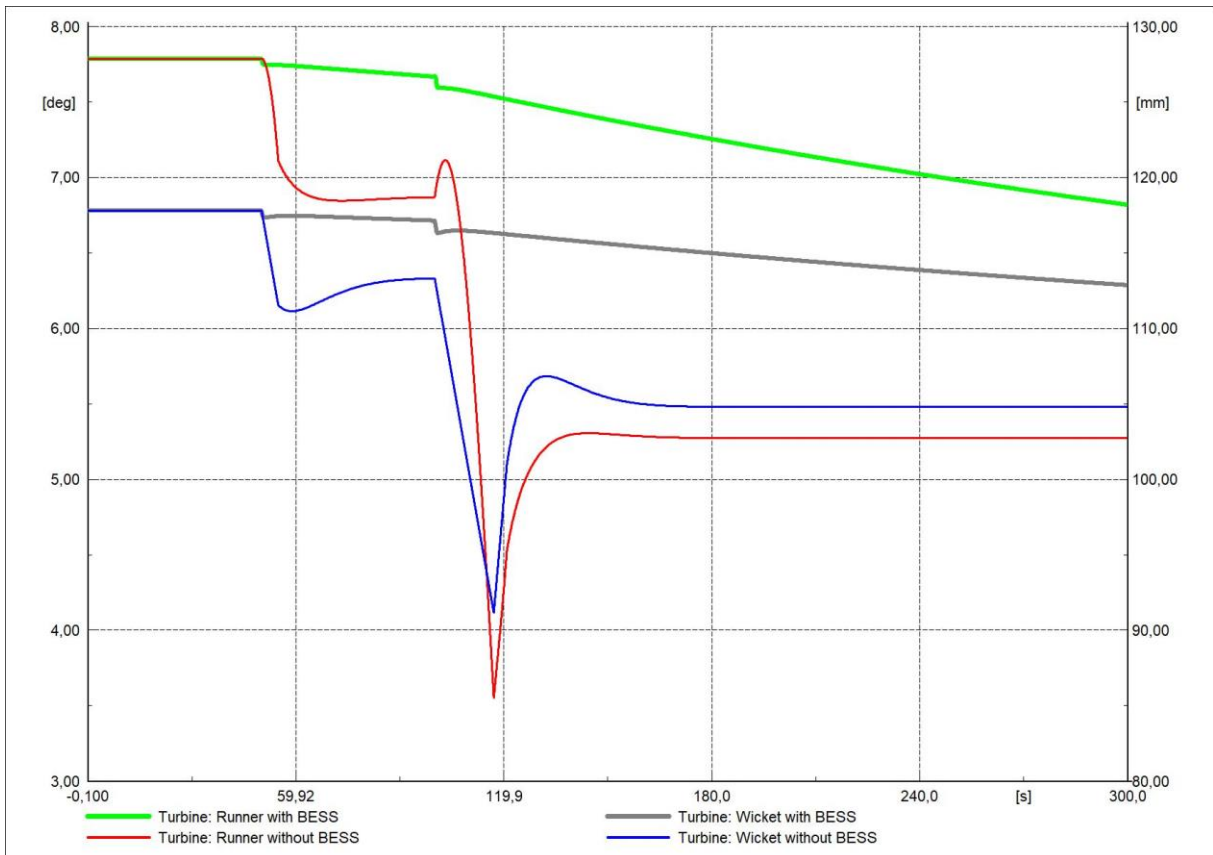
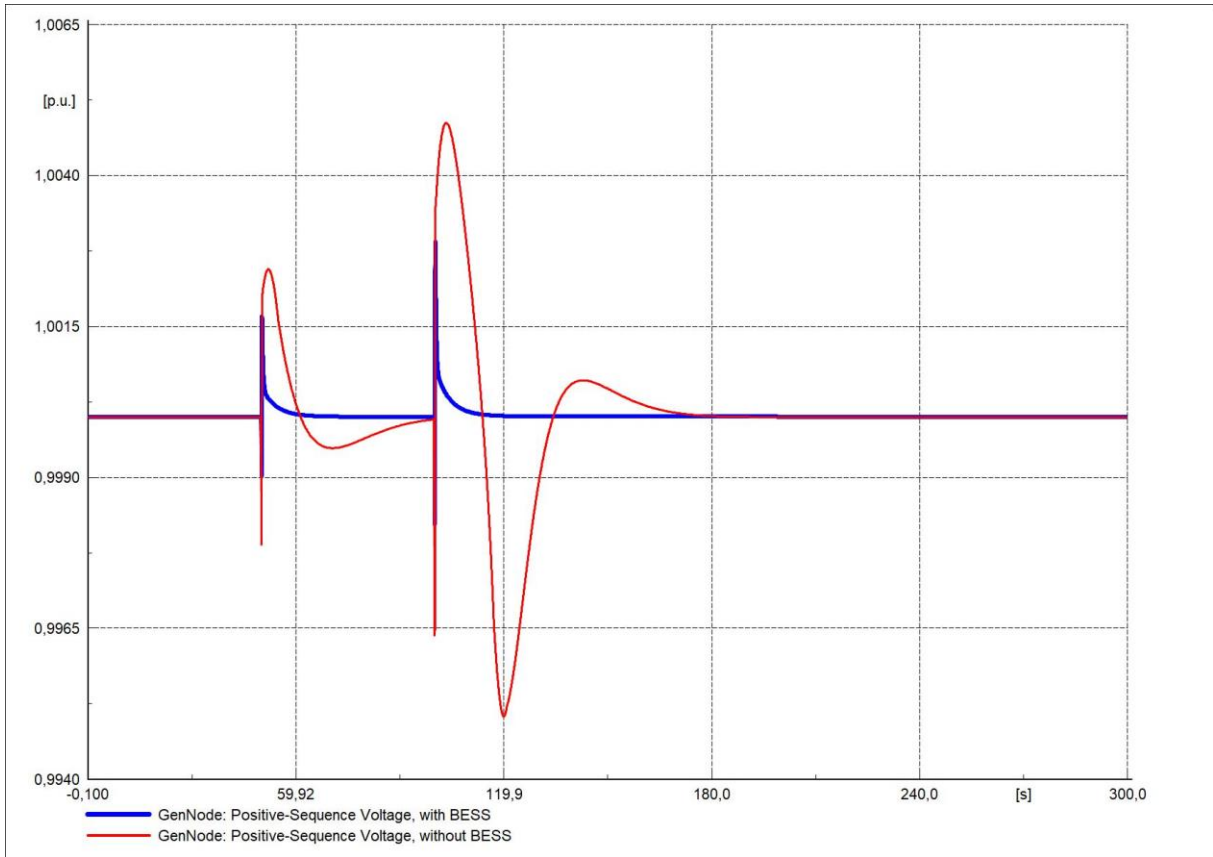

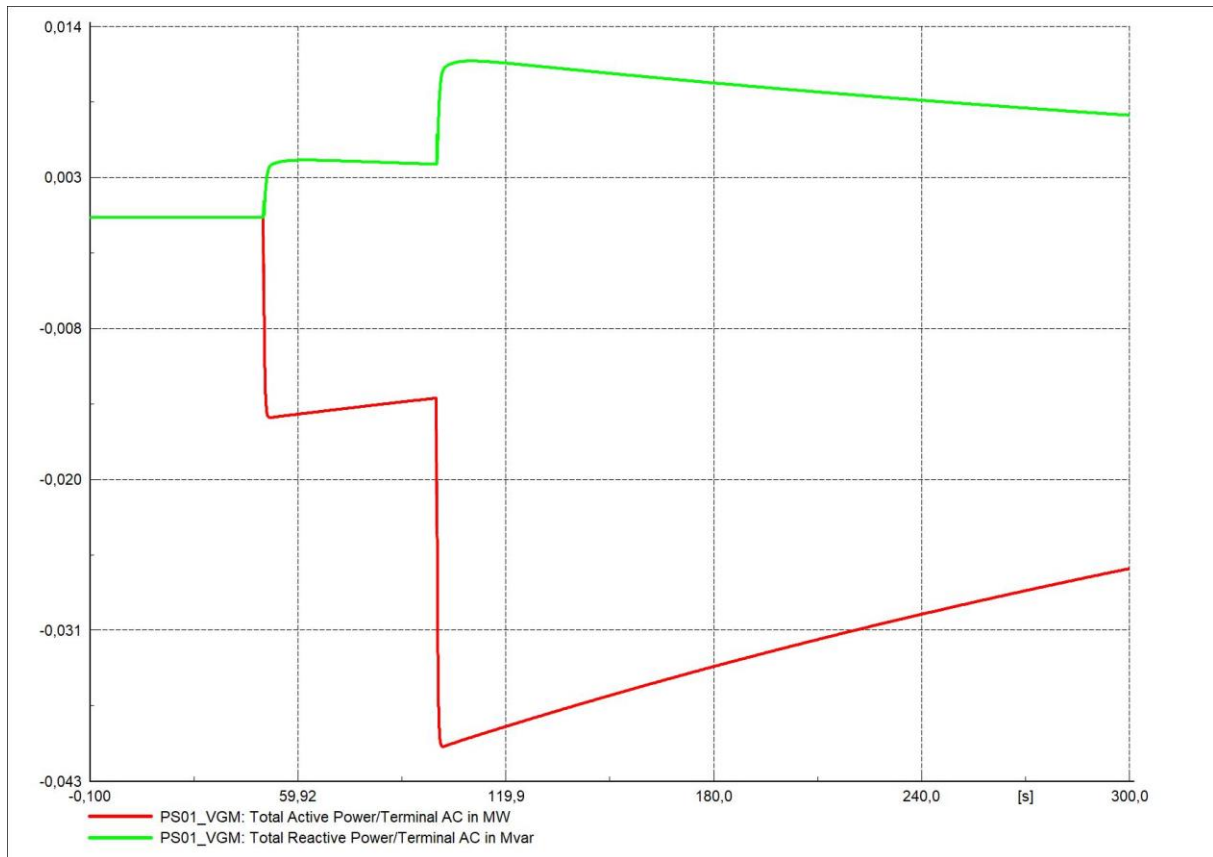

## ÅLEM ALL SCENARIOS

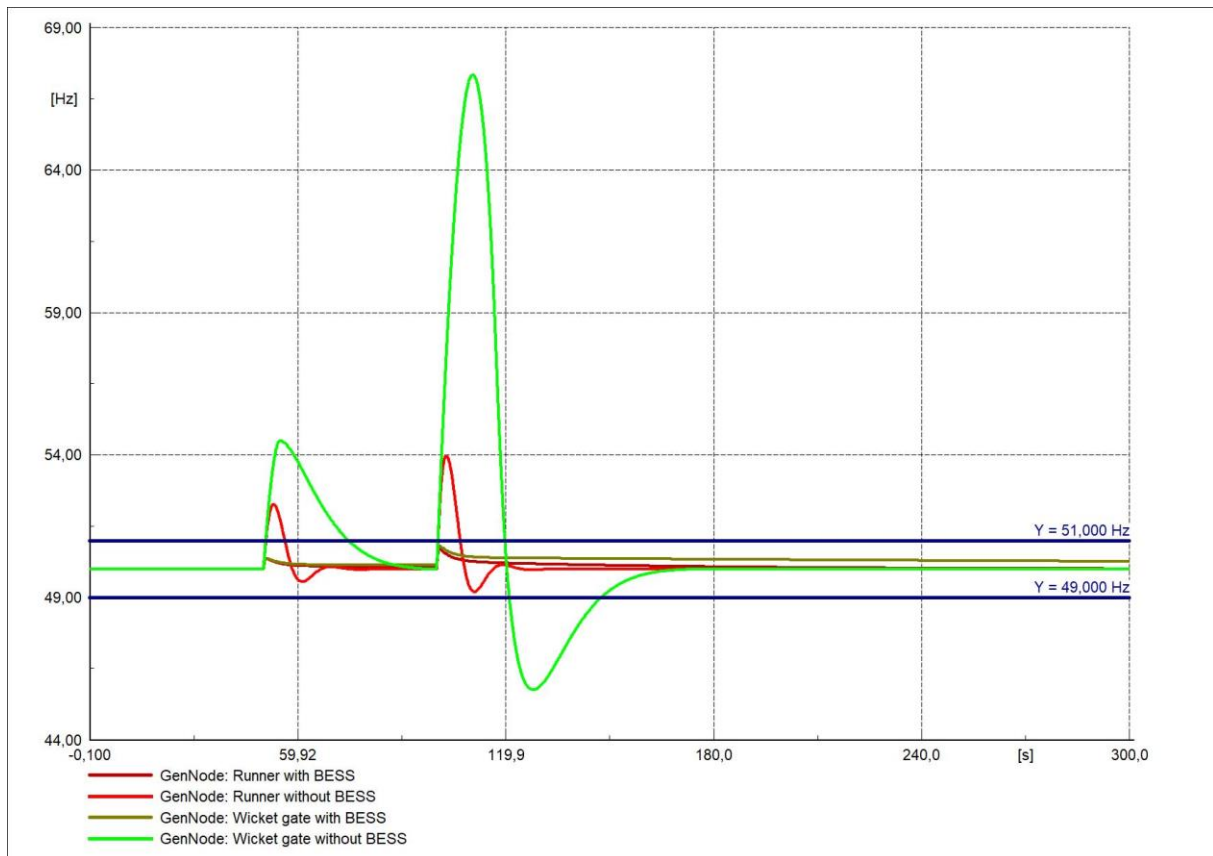

# LUDVIKA

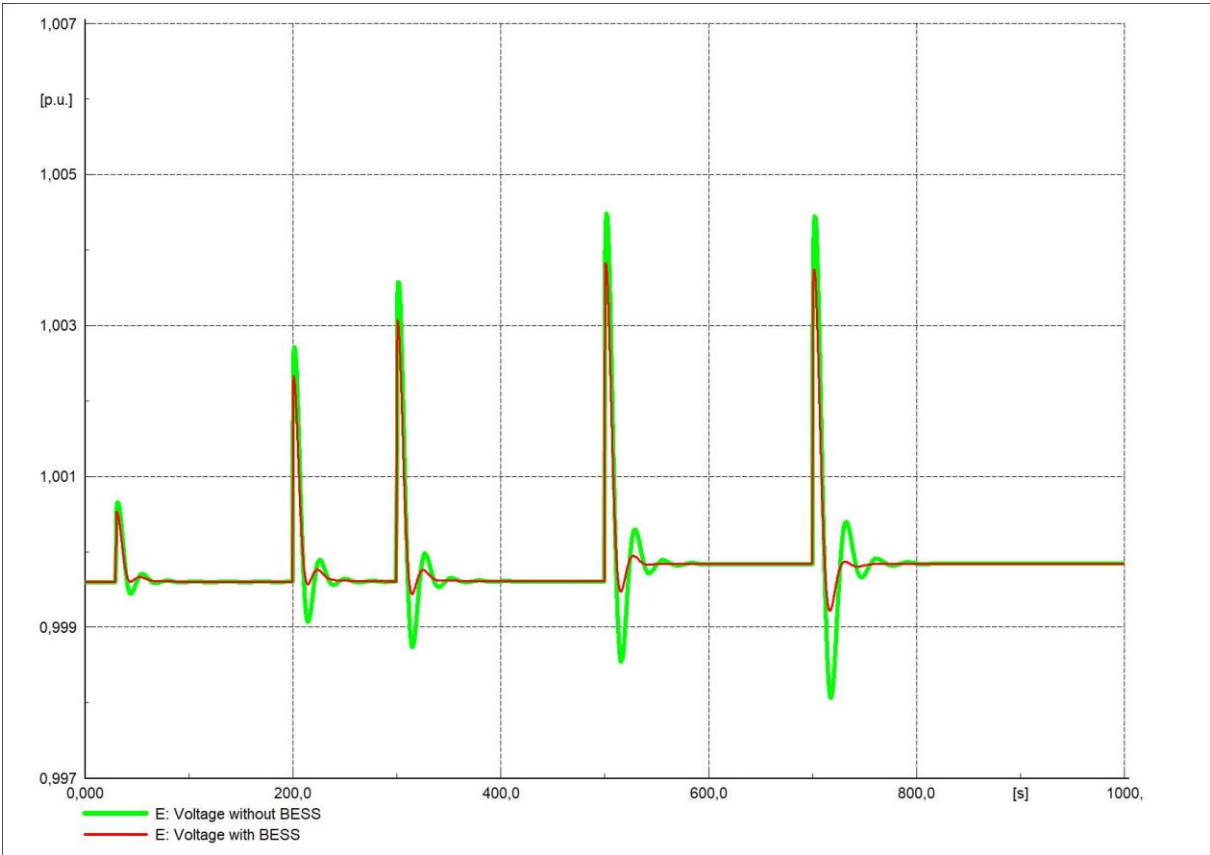
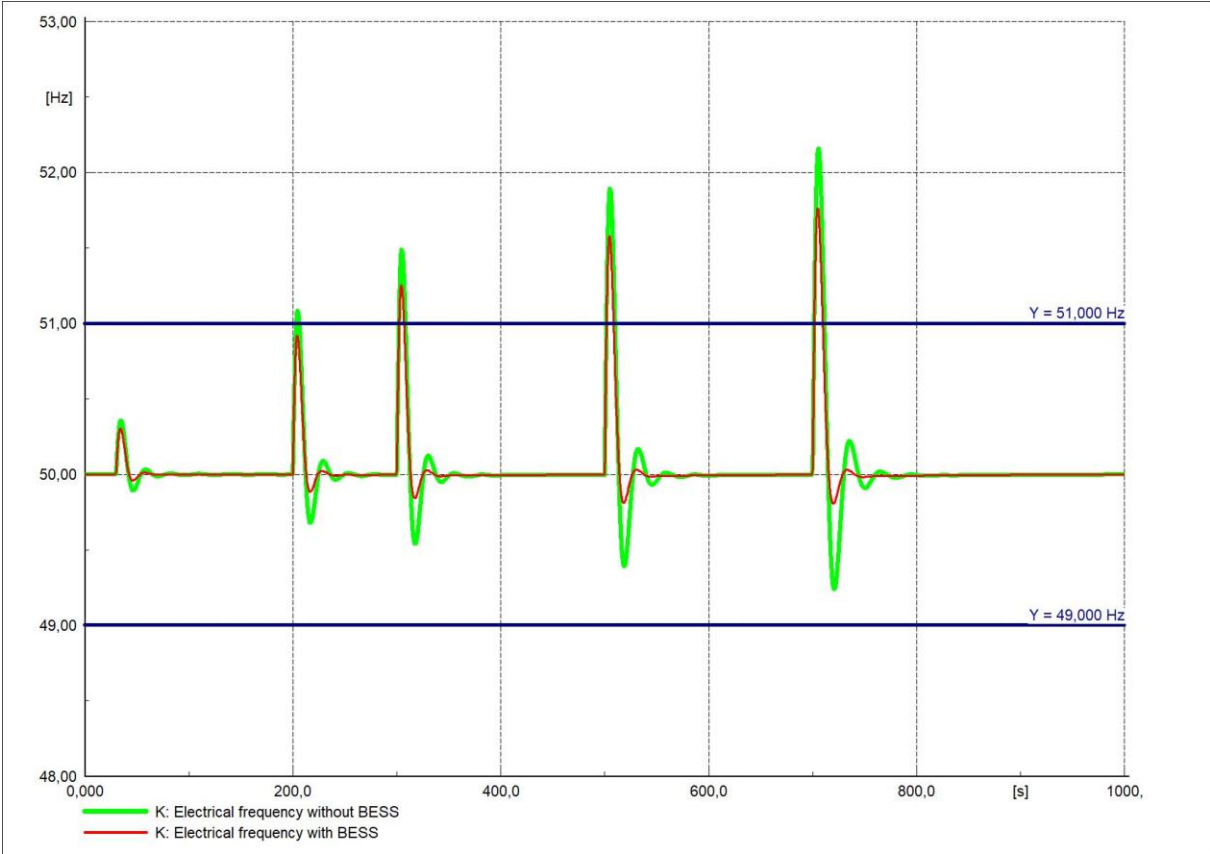

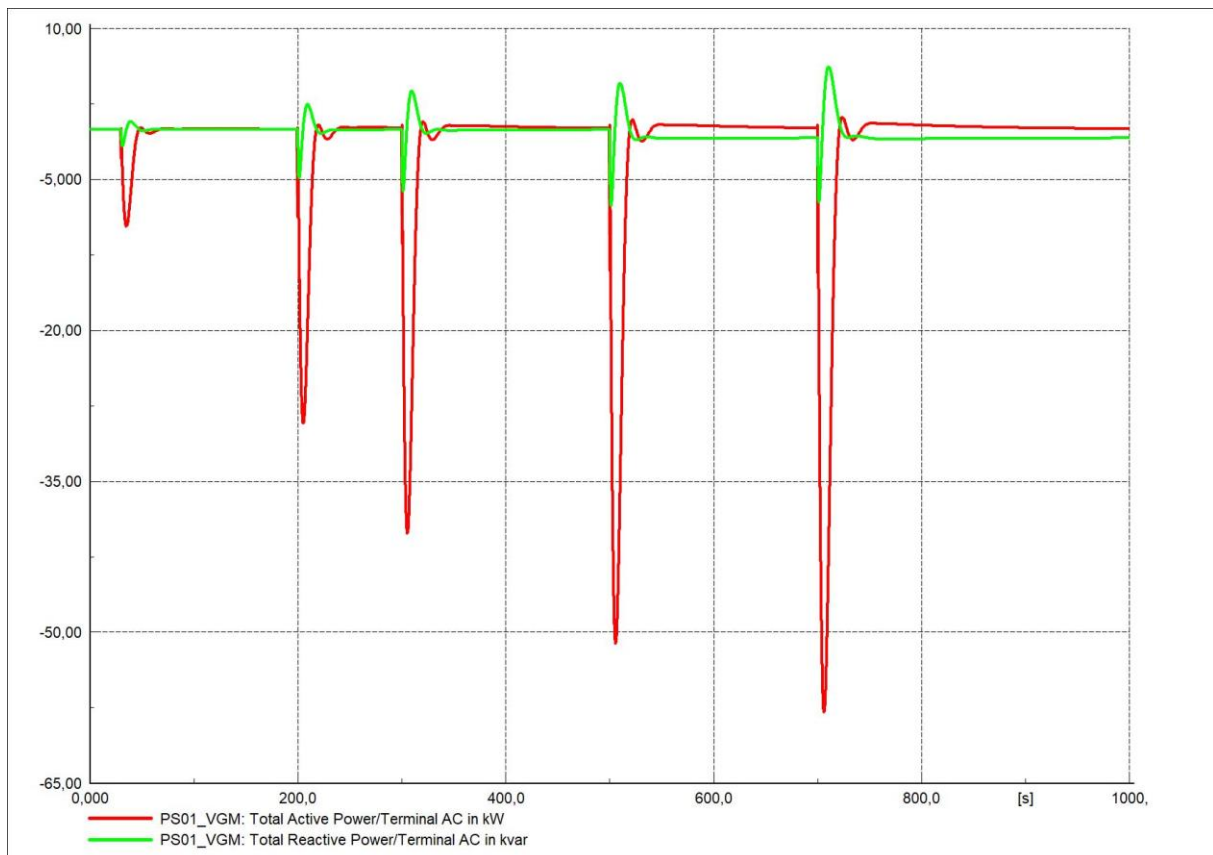
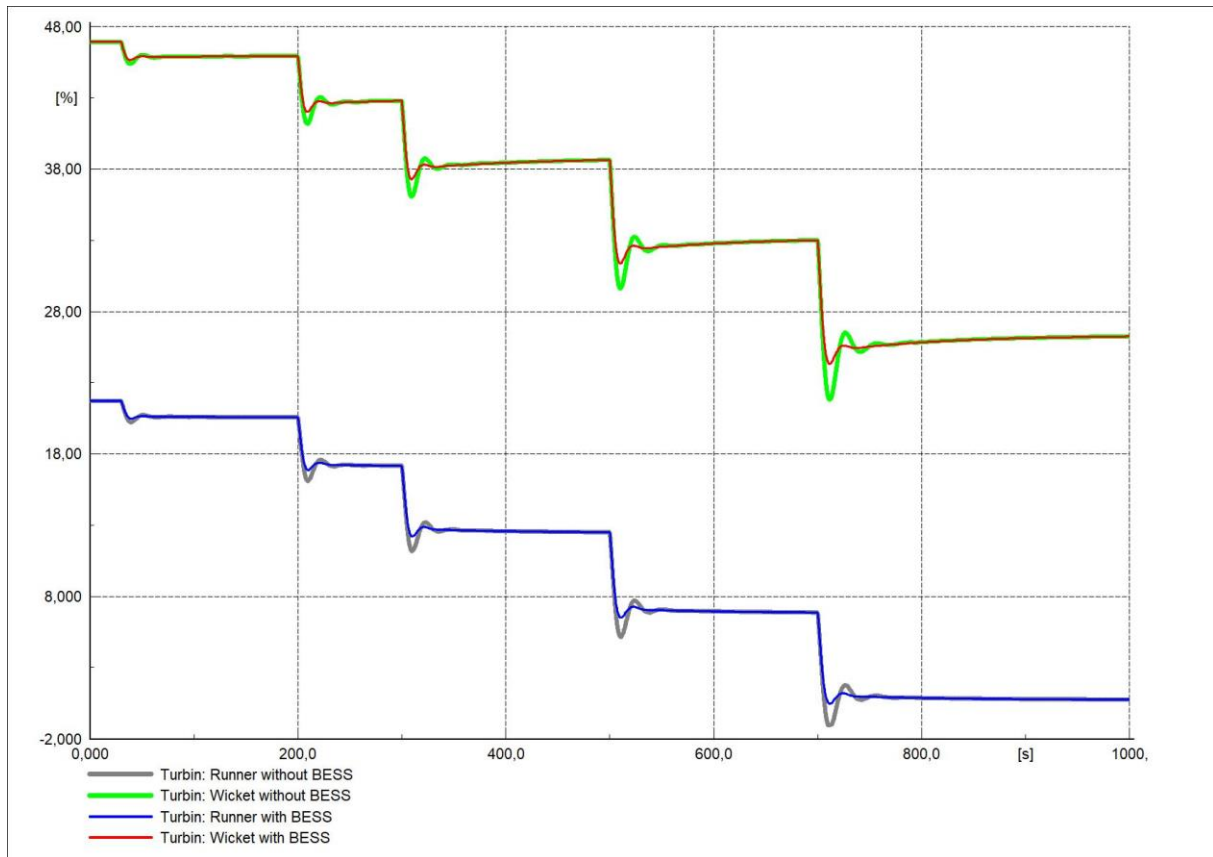





**MÄLARDALEN UNIVERSITY**  
**SWEDEN**