

Particle emissions from residential wood and biodiesel combustion

Robin Nyström



Doctoral Thesis
Thermochemical Energy Conversion Laboratory
Department of Applied Physics and Electronics
Umeå University, 2016

This work is protected by the Swedish Copyright Legislation (Act 1960:729)

ISBN: 978-91-7601-605-3

Cover illustration by Robin Nyström

Digital version available from <http://umu.diva-portal.org/>

Printed by: UmU Print Service, Umeå University, December 2016

Umeå, Sweden, 2016

Table of Contents

Abstract	iii
List of publications included	vi
Author's contribution to the papers	vii
List of other publications not included in thesis	viii
1. Introduction	1
Air pollution	1
Combustion principles	3
Biomass combustion and wood fuels	5
Diesel and liquid biofuels	7
Emission regulations	8
Aim and Objectives	9
2. Particle formation and characteristics	12
Biomass particle formation	15
Diesel particle formation	17
The effect of dilution on particle formation	18
3. Composition of combustion particles	20
Carbonaceous particle emissions	22
Inorganic particle emissions	27
4. Materials and methods	29
Wood stove setup and fuels	29
Diesel engine setup and fuels	30
Wood smoke chamber set-up	30
Sampling, instrumentation and on-line analysis	31
Chemical (off-line) characterization of PM	39

5. Results and discussion	42
Paper I	42
Paper II	44
Paper III	47
Paper IV	50
Paper V	52
Paper VI	54
Paper VII	56
6. Final remarks and conclusions	58
7. Future perspectives	62
Acknowledgment	63
References	64

Abstract

Emissions from anthropogenic combustion sources, such as vehicles and biomass combustion, contribute significantly to ambient particulate matter (PM) both on a local and global scale. Exposure to ambient PM and air pollution in general is linked to a variety of different health effects and it has been estimated that as many as 2.1 million premature deaths each year, due to cardiopulmonary disease and lung cancer, are caused by the changes in anthropogenic air pollution since pre-industrial times. There is today still a lack of information regarding the emissions of different specific particulate emission components, e.g. soot, polycyclic aromatic hydrocarbons (PAHs), oxy-PAHs combined with details about the behaviour of different fuels under varying combustion conditions. The overall objective of this work was to provide new knowledge regarding physical and chemical properties of PM from solid and liquid biofuels, which are important for the viewpoint of human health and atmospheric pollution. This was achieved by experimental studies of the combustion of biomass using a residential wood stove and by introducing biodiesel to an off-road engine, thereby investigating two major emission sources for PM and gaseous emissions.

From the two papers regarding biodiesel included in this thesis, it can be concluded that the introduction of the biodiesel, and potentially other renewable fuels, can in a considerable way change the exhaust particle emissions. This could have implications for the assessment of exhaust from engines running on biodiesel fuels, especially when introducing biodiesel in existing and older engines.

The results from the wood combustion research performed showed some important considerations regarding both specific particle properties and the influences of different burning conditions and fuels. One major finding, based on several of the included studies, was that a proper operation of a wood stove is of major importance to avoid unfavourable burning condition and elevated emissions of soot and organic particles, regardless of the wood species used. Some specific occasions during the burning phases in batch wise wood combustion were also identified as important for the overall emissions. The results from this research has given new specific insights into the emissions from wood stoves and should be of relevance for both technological development of residential appliances, emission testing/certification, information to users and legislation.

Abbreviations

AMS	Aerosol mass spectrometry
B100	100% biodiesel
B30	30% biodiesel blend
BD	Biodiesel
CO	Carbon monoxide
CO ₂	Carbon dioxide
CPC	Condensation particle counter
DGI	Dekati gravimetric impactor
DMS	Differential mobility spectrometer
DR	Dilution ratio
EC	Elemental carbon
GC-MS	Gas chromatography–mass spectrometry
NO	Nitrogen monoxide
NO ₂	Nitrogen dioxide
NO _x	Nitrogen oxides
OA	Organic aerosols
OC	Organic carbon
Oxy-PAH	Oxygenated polycyclic aromatic hydrocarbons
PAH	Polycyclic aromatic hydrocarbons
PIC	Product of incomplete combustion
PM ₁₀	Particulate matter below 10 μm
PM _{2.5}	Particulate matter below 2.5 μm
PM _{tot}	Total particulate matter

PN	Particle number
POA	Primary organic aerosol
RME	Rapeseed oil methyl ester
SD	Standard petro diesel
SMPS	Scanning mobility particle sizer
SOA	Secondary organic aerosol
TC	Total carbon
THC	Total hydrocarbons
ToF	Time of flight

List of publications included

This thesis includes the following papers, in the text referred to by their Roman numerals I-VII:

- I. **Nyström R**, Sadiktsis I, Ahmed I, Westerholm R, Koegler J, Blomberg A, Sandström T, Boman C. *Physical and chemical properties of RME biodiesel exhaust particles without engine modifications*. Fuel, 2016. 186:261-269.
- II. **Nyström R**, Pagels J, Blomberg A, Sandström T, Boman C. *Effects of dilution conditions on particle formation and size distribution in engine exhaust emissions when introducing biodiesel in comparison to standard petro diesel*. Manuscript.
- III. **Nyström R**, Blomberg A, Pagels J, Sandström T, Boman C. *Evaluation of a novel chamber set-up for human exposures of biomass combustion aerosols*. Submitted to Inhalation Toxicology, November 2016.
- IV. **Nyström R**, Lindgren R, Avagyan R, Westerholm R, Lundstedt S, Boman C. *Influence of wood type and combustion conditions on particle emission characteristics in a common Nordic wood stove*. Submitted to Energy & Fuels, October 2016.
- V. Avagyan R, **Nyström R**, Boman C, Westerholm R. *Particulate hydroxy-PAH emissions from a residential wood log stove using different fuels and burning conditions*. Atmospheric Environment, 2016. 140:1-9.
- VI. Eriksson AC, Nordin EZ, **Nyström R**, Pettersson E, Swietlicki E, Bergvall C, Westerholm R, Boman C, Pagels JH. *Particulate PAH emissions from residential biomass combustion: Time-resolved analysis with aerosol mass spectrometry*. Environmental Science & Technology, 2014. 48(12): 7143-7150.
- VII. Nordin EZ, Uski O, **Nyström R**, Jalava P, Eriksson AC, Genberg J, Roldin P, Bergvall C, Westerholm R, Jokiniemi J, Pagels JH, Boman C, Hirvonen MR. *Influence of ozone initiated processing on the toxicity of aerosol particles from small scale wood combustion*. Atmospheric Environment, 2015. 102:282-9.

Author's contribution to the papers

- I. I participated in planning of the study and carried out a major part of the experimental work, including combustion experiments and all particle sampling. I analysed most of the experimental data, did most of the calculations. I wrote the major part of the paper.
- II. I was largely involved in planning of the study and carried out the experimental work. I evaluated the experimental data, made the calculations. I wrote the major part of the paper.
- III. I was largely involved in the planning of the measurements and carried out the experimental work. I evaluated the data and wrote the major part of the paper.
- IV. I participated in planning of the work, including design of the experimental matrix. I played a major role during the combustion experiments and carried out all particle sampling. I evaluated the experimental data and wrote the major part of the paper.
- V. I participated in planning of the work, including design of the experimental matrix. I played a major role during the combustion experiments and carried out all particle sampling. I was involved in the evaluation of experimental data and performed the emission calculations. I wrote parts of the paper.
- VI. I participated in planning of the study and carried out a major part of the combustion experiments as well as parts of the particle sampling. I was involved in calculations and evaluation of the experimental data. I contributed to writing parts of the paper.
- VII. I participated in the planning of the study and carried out the combustion experiments as well as parts of the particle sampling. I was involved in the evaluation of the experimental data and in writing parts of the paper.

List of other publications not included in thesis

Peer reviewed papers

- VIII. Martinsson J, Eriksson AC, Nielsen IE, Malmberg VB, Ahlberg E, Andersen C, Lindgren R, **Nyström R**, Nordin EZ, Brune WH, Svenningsson B, Swietlicki E, Boman C and Pagels JH. *Impacts of Combustion Conditions and Photochemical Processing on the Light Absorption of Biomass Combustion Aerosol*. Environmental Science & Technology. 2015.
- IX. Muala A, Nicklasson H, Boman, C, Swietlicki E, **Nyström R**, Pettersson E, Bosson J.A, Rissler J, Blomberg A, Sandström T and Löndahl J. *Respiratory Tract Deposition of Inhaled Wood Smoke Particles in Healthy Volunteers*. Journal of aerosol medicine and pulmonary drug delivery. 2015;28(4):237-46.
- X. Avagyan R, **Nyström R**, Boman C, Westerholm R. *Determination of hydroxylated polycyclic aromatic hydrocarbons by HPLC-photoionization tandem mass spectrometry in wood smoke particles and soil samples*. Analytical and Bioanalytical Chemistry. 2015;407(16):4523-34.
- XI. Muala A, Rankin G, Sehlstedt M, Unosson J, Bosson JA, Behndig A, Pourazar J, **Nyström R**, Pettersson E, Bergvall C, Westerholm R, Jalava PI, Happonen MS, Uski O, Hirvonen, MR, Kelly FJ, Mudway IS, Blomberg A, Boman C and Sandström T. *Acute exposure to wood smoke from incomplete combustion - indications of cytotoxicity*. Particle and Fibre Toxicology. 2015;12.
- XII. Hunter AL, Unosson J, Bosson JA, Langrish JP, Pourazar J, Raftis JB, Miller MR, Lucking, AJ, Boman, C, **Nyström R**, Donaldson K, Flapan, AD, Shah, ASv, Pung, L, Sadiktsis I, Masala S, Westerholm R, Sandstrom T, Blomberg A, Newby DE and Mills NL. *Effect of wood smoke exposure on vascular function and thrombus formation in healthy fire fighters*. Particle and Fibre toxicology. 2014; 11:62.

- XIII. Unosson J, Blomberg A, Sandström T, Muala A, Boman C, **Nyström R**, Westerholm R, Mills NL, Newby DE, Langrish JP and Bosson JA. *Exposure to wood smoke increases arterial stiffness and decreases heart rate variability in humans*. Particle and Fibre Toxicology. 2013;10.
- XIV. Muala A, Nicklasson H, Boman C, **Nyström R**, Swietlicki E, Bosson-Damewood J, Blomberg A, Sandström T and Löndahl J. *Respiratory tract deposition of inhaled wood smoke particle in healthy volunteers and patients with chronic obstructive pulmonary disease*. European Respiratory Journal. 2013;42.
- XV. Rankin G, Sehlstedt M, Pourazar J, Muala A, **Nyström R**, Boman C, Blomberg A and Sandström T. *Emissions from incomplete wood combustion cause an immune response in endobronchial biopsies*. European Respiratory Journal. 2013;42.

Reports

Jokiniemi, J., Tissari, J. et al., *BIOHEALTH – Health effects of particulate emissions from small scale biomass combustion*, ERA-NET Bioenergy Program. 6th Joint Call on Clean Biomass Combustion Final Report, 2013

Boman C, **Nyström R**, Wiinikka H, Grönberg C, Öhrman O, Pettersson E, Sandström T, Blomberg A, Mudway IS, Westerholm R, Pagels J, Swietlicki E, Genberg J. *Inverkan av förbränningsteknik och bränsle på hälsofarligheten av partikelemissioner från småskalig biobränsleeldning*. Swedish Energy Agency, Report P30824-1, and also as Umeå University, ISSN 1653-0551, ETPC Report 11-06, 2011

Boman C, **Nyström R**, Sandström T, Blomberg A, Wiinikka H, Grönberg C, Öhrman O, Bäfver L, Rönnbäck M, Ryde D, Johansson M, Pagels J, Nordin E, Rissler J, Swietlicki E, Eriksson A, Genberg J, Pettersson E, Larsson L, Strand M. *Emissioner från småskalig värmeförsörjning med biobränslen - Ett samordnat projekt som berör hälsopåverkande partikel- och tungmetallutsläpp från traditionella och alternativa biobränslen*. Swedish Energy Agency, Report P30824-1 and also as Umeå University, ISSN 1653-0551, ETPC Report 11-05, 2011.

Leffler J, Öhman R, Wiinikka H, Pagels J, Eriksson A, Nordin E, Rissler J, Boman C, **Nyström R**, Pettersson E. *Inverkan på teknik och handhavande på emissionsprestanda för moderna vedeldade lokaleldstäder*. ETC Report 2010-20, July 2010.

Pagels J, Eriksson A, Nordin E, Rissler J, Boman C, **Nyström R**, Pettersson E, Wiinikka H. *Applicering av aerosol masspektrometri för tidsupplöst stoftprovtagning från vedeldade lokaleldstäder*. Swedish Energy Agency, Report July 2010.

Boman C, **Nyström R**, Boström D. *Förbränningsstudier i en småskalig pelletsbrännare med förbränning av pellets från Storuman (BioStor)*. Industrial commission from Skellefteå Kraft, June 2010.

1. Introduction

Air pollution

The air we breathe contains many different components in gaseous, liquid and solid form, to a large extent invisible to the naked eye. The solid and liquid components are defined as particulate matter (PM), associated with different physical and chemical properties that may affect both human health and the atmosphere. When these solid or liquid particles are emitted and suspended in a gas (such as air), they can also be referred to as aerosols.

Exposure to ambient PM and air pollution in general is linked to a variety of different health effects such as increased risk of cardiovascular diseases, airway inflammation and the severity of asthma [1, 2]. It has been estimated that as many as 2.1 million premature deaths each year, due to cardiopulmonary disease and lung cancer, are caused by the changes in anthropogenic air pollution since pre-industrial times [3]. To gain a deeper understanding of the underlying mechanisms and also to assess the effects of different sources, it is important to consider the different properties of PM of different origin. It has been shown that the physical and chemical properties of PM such as mass, size, surface area, chemical composition and oxidative capacity influence the toxicity of the particles [4]. Particles generated by human activity, i.e. anthropogenic PM, are often smaller than the particles that human protective systems are effective against. For this reason, they have a greater chance of causing health effects.

Furthermore, PM has the ability to affect the atmosphere by its ability to scatter and absorb solar and terrestrial radiation. It is also involved in the formation of clouds and precipitation, as cloud condensation and ice nuclei. In addition, particles affect the abundance and distribution of atmospheric trace gases by heterogeneous chemical reactions and other multiphase processes. Thus, PM can have both a cooling and warming effect on the atmosphere, depending on its properties, and therefore plays a central role for the global climate [5]. Some specific PM components such as “black carbon”, i.e. the sooty fraction of PM, have recently gained considerable interest due to its role for the climate system [6].

Anthropogenic air pollution is not a new phenomenon; already during the Roman times the philosopher Seneca wrote one of the earliest accounts of

health and air pollution. In his *Moral Letters to Lucillus* he describes how his mental vigour and health improves when he leaves the “ruinous mess of steam and soot” in Rome [7]. During the 13th century, coal started to replace the domestic burning of wood, which in turn led to even more severe air pollution problems which in the end resulted in a difficult to uphold ban on coal burning in medieval England [8]. Early in the 20th century, episodes of extreme air pollution in the Meuse Valley, (Belgium, 1930), Donora (United States, 1948) and Pozo Rico (Mexico, 1950), and the Great London Smog (United Kingdom, 1952) added new insights on how air pollution and acute exposure affected mortality. During this time, the “London smog” became a well-known threat to human health. Reassessments of the Great London smog estimate that as many as 12,000 excess death were caused by this occurrence where unfavourable metrological conditions caused the city to be embedded in acidic pollution [9]. This is considered as a landmark in air pollution history, and it caused several regulations to be set, with the aim of limiting the number of extreme air pollution events.

Up until the 1990s it was still a question of whether particulate matter increased total mortality or whether it just shortened the lifespan of already “weakened” sick individuals. With the “six cities study”, where 8,111 adults living in six major US cities were followed for 14 to 16 years, it was found that the mortality was significant higher in the most polluted cities in comparison to the lesser polluted areas when taking in factors like age, sex, smoking, body mass index and low education [10]. Based on this extensive and pioneering data, it could also be confirmed that the PM emitted from vehicles and combustion sources had the strongest link to mortality [11].

Accordingly, it has been shown that exposure to a higher concentration of PM air pollution is more harmful than exposure to lower concentrations, but it would seem that there is no lower threshold where exposure does not cause adverse health effects [12]. A recent study, considered as a guideline, has shown that the increased risk of natural cause mortality is raised for every 5 $\mu\text{g}/\text{m}^3$ increase of PM smaller than 2.5 μm . This effect is valid even when the concentrations are below the current EU guidelines of an annual mean of < 25 $\mu\text{g}/\text{m}^3$ [13].

Major sources of ambient particulate air pollution are the emissions generated by combustion engines in vehicles [14] and traditional

residential biomass combustion. An increasing interest in the role of residential wood burning in this context has been seen, and it has been estimated that biomass combustion (especially during the winter season) can in many countries be a significant contributor to the total PM [15, 16]. In rural parts of Europe as much as 70% of all organic PM in the ambient air during wintertime has been proposed to originate from residential wood combustion [17]. Since the use of domestic wood burning in Europe is expected to increase even further, at the same time as other important sources are reducing their emissions (e.g. the traffic sector), this sector is estimated by 2020 to become the dominant source of fine (below 2.5 μm) primary particulate air pollution in Europe [18].

Combustion principles

During combustion, which is an exothermic process, energy is released by oxidizing a combustible fuel containing carbon and hydrogen to mainly form carbon dioxide (CO_2) and water (H_2O). The chemically bound energy released during this process is what the human species and our ancestors have utilized for heat and light for as long as a million years [19]. The actual combustion process for a solid fuel like biomass is very complex and involves many physical and chemical transformation steps. Combustion occurs mainly in the gas phase, as it is the combustible gases that burns. Therefore, the solid fuel first has to be volatilized before it can be oxidized further and ignited, and this process actually requires energy in order to thermally cleave bonds present in the fuel.

For a liquid fuel, the vapours of the fuel are ignited, and to achieve that the liquid should be at or above its flash point. The flash point of a liquid is the lowest temperature where there is enough concentration of evaporated fuel to start the combustion.

As mentioned above, combustion of a biomass is a very complex process as it involves heterogeneous fuels giving a multiphase reaction system. During biomass combustion, the solid fuel particle proceeds in different, overlapping, steps that can be divided into drying where the water is removed from the particle, pyrolysis/devolatilization where the fuel is converted into gas and, finally, solid char conversion/combustion where most of the fuel has volatilized leaving a carbon rich residue. In an application with continuous fuel feeding, these processes will take place simultaneously, while during batch-wise combustion they will follow each other in distinct stages. This is illustrated in **Figure 1** where the basic steps during thermal conversion of the solid biomass fuel combined with some

additional information about the formation of different by-products for each combustion stage is shown.

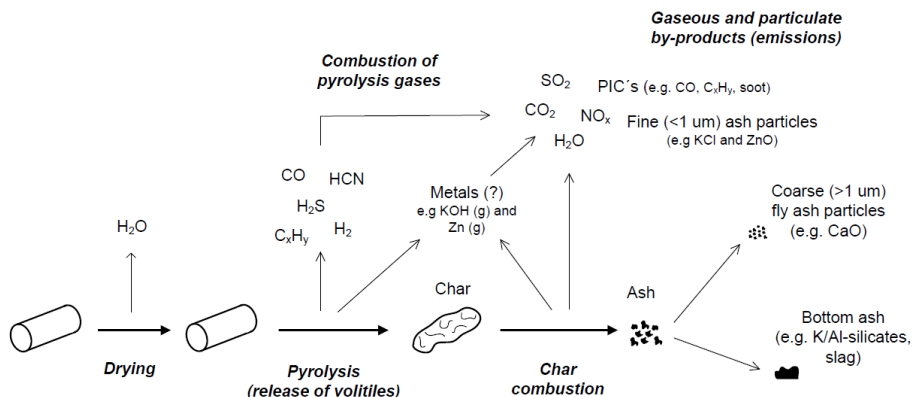

Figure 1. Schematic illustration of the different stages during combustion of a solid biomass fuel particle as illustrated by Boman [20].

In practical applications, it is difficult to achieve a total complete oxidation with almost all combustion processes being somewhat incomplete. The theoretical requirements for obtaining complete combustion include four different conditions that will have to be fulfilled at all stages of the combustion process:

- i) Sufficient supply of air (oxygen) for complete oxidation
- ii) Sufficiently high temperature for all chemical reaction steps
- iii) Sufficiently long residence time at (sufficiently) high temperature (i.e. chemical reaction time)
- iv) Sufficient mixing (turbulence) of fuel components and air

When these conditions are not fulfilled, the fuel gases cannot react and be oxidized completely and different un-burned products than CO_2 and H_2O are formed. These are often referred to as products of incomplete combustion (PIC), and can be both particulate and gaseous: some examples are carbon monoxide (CO), volatile hydrocarbons (VOC), polycyclic aromatic hydrocarbons (PAH) and soot particles, which all have different adverse environmental health effects.

CO is an intermediate product in the oxidation steps of carbon leading to the formation of CO_2 and may remain in high concentrations in flue gas

from combustion when the oxidation to CO_2 is hampered, e.g. by sub stoichiometric O_2 . CO is highly toxic even at low concentrations: when inhaled, it readily reacts by bonding to the site in haemoglobin where O_2 is normally bonded and produces carboxyhaemoglobin, effectively inhibiting O_2 transport with the vascular system.

Other important inorganic gas emissions in combustion processes are hydrochloric acid (HCl), sulphur dioxide (SO_2) and nitrogen oxides (NO_x – i.e. $\text{NO} + \text{NO}_2$). NO_x emissions are in general rather low during residential biomass combustion, but higher from diesel engines, and are formed via three different routes; thermal NO_x , fuel- NO_x or prompt NO_x . Thermal NO_x is formed at high temperature (>1000 °C) when N_2 in the combustion air is oxidized and converted into NO_x . This is especially relevant in combustion engines because of the higher temperature. Fuel NO_x is, as the name tells us, formed from nitrogen in the fuel during combustion of especially biomass [21]. Finally, prompt NO_x is also formed from the N_2 in the air, but via processes reacting with radicals in the flames. This process is often minimal when the fuel contains nitrogen itself, but it has been identified as an important factor when combusting oxygenated fuels like biodiesel [22]. It has been argued that this is because the double bonds in biodiesel fuel form more free radicals during combustion, and therefore advance prompt NO_x formation [23].

Biomass combustion and wood fuels

In the industrialized part of the world, combustion of biomass occurs in several different types of facilities, from small-scale domestic appliances (e.g. wood stoves, wood log boilers, masonry heaters and pellet burners) to large industrial plants for heat and power production (i.e. fixed bed furnaces and fluidized bed boilers). Whilst the operation of industrial plants is controlled rigorously with extensive flue gas cleaning, the domestic ones may be poorly designed or lack proper chimneys, often resulting in reduced combustion efficiency and increased emissions of PIC. There are exceptions, e.g. modern domestic pellet burners and boilers, but for domestic log stoves and older appliances in general, this is very often the case.

In this thesis, the focus is on domestic wood stoves, where logs are most commonly used instead of the upgraded biomass fuels, e.g. powder, pellets and briquettes. The use of different wood fuels varies depending on where in the world it takes place. In Sweden, the most used firewood is often

silver birch, Scots pine and Norway spruce [24]. Basically, there are two types of wood families, i.e. hardwood (e.g. birch and aspen) and softwood (e.g. pine and spruce). As the name hardwood indicates, these woods are most often harder (more dense) than softwood, but there are exceptions as the density of both groups overlap [25].

Hardwoods comes from angiosperm trees, which have broad leaves and reproduce by flowers, while softwood is wood from gymnosperm trees, often evergreen conifers with needles. Hardwoods are constructed in a more complex structure than softwoods, often resulting in a slower growth than softwoods and higher density. Because of the commonly higher density, hardwood also has a higher energy content per volume [25], a reason why it often burns hotter and longer than softwood, which tends to burn quickly while not producing as much heat as hardwood.

The actual physical properties of the wood also affect the combustion performance, and a freshly cut tree contains as much as 45% water. Therefore, firewood is normally split into smaller pieces (logs) and seasoned outdoors, while protected from rain, to let the water in the wood evaporate. For normally used logs, it is recommended to store the wood for a minimum of two seasons before use, and during this time the moisture content is reduced to around 18–20%, which is the recommended level by the stove manufacturers. This makes it easier to ignite, improves the heat release and in general reduces the emissions compared to the combustion of larger moist logs. However, when the wood is too dry, it can also cause problems in stoves and boilers due to too high burn rates resulting in episodes of flashovers and higher overall emissions.

Generally speaking, it can be concluded that combustion of wood and other biomass in general is a heterogeneous process with both emissions levels and particle characteristics varying with applied combustion technologies. In addition, the combustion technology used, type of fuel (e.g. logs, pellets), fuel load, source (e.g. wood species) and fuel quality (e.g. moisture content, size, contaminants) also affects the burning conditions [26-29]. An example of how the appliance affects the PM emissions is that emissions from modern biomass combustion appliances (mainly pellet systems), with fairly controlled combustion are commonly dominated by inorganic alkali salts [30], while emissions from older technologies (e.g. wood stoves) to a much larger extent are composed of soot and organics (e.g. PAH) [31].

Diesel and liquid biofuels

As discussed earlier, a major contributor to air pollution in urban environments is exhaust emissions from the traffic sector. Generally speaking, diesel engines have higher emissions of primary PM compared to petrol engines. Diesel engines have, therefore, been in focus during numerous toxicological studies to examine the health effects of vehicle exhaust. Overall, the results have shown adverse effects on both the cardiovascular [32] as well as the respiratory systems [33].

As more knowledge about diesel engine exhaust, its formation, properties and measures for reduction, have become available, a new potential emission source is being introduced. There is today a global drive towards finding sustainable and clean bio-based alternative fuels to replace petrol and diesel for the transport sector. Within EU directive 2009/28/EC, a goal has been set for a minimum of 10% biofuels in every EU member state by 2020, and the US Environmental Protection Agency's Renewable Fuel Standard contains targets to quadruple the use of biofuels in the US transport sector by 2022 [34]. In light of this, considerable R&D efforts have been undertaken during the last decade with some alternative fuels already being introduced to the market. One of the most established biofuels on today's international market is biodiesel, accounting for 82% of the total biofuel production in Europe during 2011 [35]. It has been estimated that the global transportation energy use is expected to increase by an average of 1.8% per year from 2005 to 2035 and this, combined with the different goals set by the EU and US, has led to a rapid increase in biodiesel production. There are some advantages with using biodiesel as a fuel i.e.; it is produced from renewable resources, is virtually free from sulphur and aromatic compounds, is nontoxic and much more biodegradable than SD [36]. Today, the major part of the biodiesel produced in Europe is made from rape seed and is called rapeseed oil methyl ester (RME) while in the US the most common form is produced from soy beans and is called soy bean oil methyl ester (SME). Although there is a positive climate-related impact of replacing fossil fuels with biofuels, there is still not enough known about the exhaust particles from biodiesel and other biofuels, especially regarding their specific properties and potential health effects during exposure [37].

When comparing emissions from biodiesel-fuelled engines to engines fuelled with petro diesel, there are considerable variations in the emission

data reported, probably explained by the fact that the emissions are strongly linked to engine technology and operating conditions [38], as well as the origin and quality of the biodiesel [39]. In a recent review, however, it was concluded that most studies of biodiesel exhaust have reported an increase in NO_x emissions and a reduction in PM emissions, as well as a decrease in the emissions of CO, total (gaseous) hydrocarbons (THC) and PAH [38]. However, emission data of oxygenated PAHs (oxy-PAH) from biodiesel combustion is scarce, but has been reported to increase when compared to SD [40].

Accordingly, there seems to be clear evidence that particulate matter in engine exhaust causes adverse health effects. With the introduction of biodiesel, the concentration of PM can be significantly reduced, and in one reported study where five different biodiesel types was tested during the same conditions, a reduction of 53–69% could be observed [38]. At the same time, recent research has shown that PM originating from biodiesel combustion, compared to SD, has stronger mutagenic effects [41] and increased pro-inflammatory responses [42]. However, rather scarce information is available and some inconsistencies still remain. A later review of *in vitro* and animal studies showed increased cytotoxicity and stronger irritant effects, but with variable mutagenicity [43]. Recently, a human exposure study where the acute cardiovascular effects of RME biodiesel combustion was compared to standard diesel fuel, showed similar effects from both fuels, even though the mass concentration was 50% lower for the biodiesel [44]. More research is therefore needed to facilitate the introduction of different biofuels in the transport sector.

Emission regulations

For solid biomass combustion, the situation regarding emission regulations is complex. Large-scale combustion plants (50 MW and greater) have stringent rules while the small-scale appliances are less regulated. However, during 2015 the EU commission published new emission regulations for both larger (1–50 MW, MCP-directive 2015/2193) and smaller biomass combustion appliances (solid fuel boilers of <70 kW and local space heaters <50 kW, Eco-Design directive 2015/1189). The Eco-Design directive is the first step that introduces energy labelling of residential solid fuel boilers, followed by emissions regulations later on. There are many of these regulations in place already today, but most of them are not mandatory. There is, however, large difficulties associated

with having harmonized emissions regulations between countries, something that will hopefully be solved with the previously mentioned Eco-Design initiative. Examples of voluntary national regulations already in practice today are among others the Swedish “P-märkning” and the Nordic collaboration “Svanen” (the Swan).

The emissions from vehicles on the other hand is regulated by the European emission standards (for member countries) in the European Union. For light vehicles (cars and light trucks), these standards are typically referred to as Euro 1, Euro 2 etc., while for heavy duty vehicles (heavy trucks and buses), the roman letter is used instead (i.e. Euro I, Euro II). These standards regulate the emissions during a specified test cycle of nitrogen oxides (NO_x), total hydrocarbons, non-methane hydro carbons, CO and PM (mass concentration). In the latest standard for light vehicles and passenger cars (Euro 6), a level for particle numbers is also included. For each new Euro emission standard, the emissions permitted have been reduced, resulting in tougher demands on car and truck manufacturers, forcing new technology to being developed and implemented.

Aim and Objectives

The overall objective of this work was to provide new knowledge regarding the physical and chemical properties of particulate matter emissions from combustion of solid and liquid biofuels. The focus of the research carried out was on experimental studies of; i) combustion of biomass in residential wood stoves, and ii) introduction of biodiesel in existing engines. The studies were carried out using an experimental approach in two different laboratory settings under controlled and reproducible testing and sampling conditions, which made it possible to investigate the influence from operation and fuel parameters on the specific particle emission properties and components. Thus, the research investigated two major emission sources for fine particulate emissions, with relevance to both human health and atmospheric pollution.

Specific aims of each paper

- I. The objective of **Paper I** was to study the effect on particle emissions when introducing biodiesel in an existing older engine originally operated on petro diesel, with a focus on the characteristics of particulate carbonaceous matter and PAH/Oxy-PAH as well as fine particle size distribution.
- II. The objective of **Paper II** was to study the effects of dilution conditions on the nucleation mode particle formation and size distribution in the exhaust emissions from an off road engine, when introducing RME biodiesel in comparison to standard petro diesel. Particle size distribution and number concentration were determined on-line to elucidate differences in the raw exhaust particles versus the diluted exhaust particles in two subsequent sampling points with different dilution ratios. In addition, the influences on the exhaust particle properties of changing the lubrication oil was investigated.
- III. The objective of **Paper III** was to evaluate a novel chamber set-up designed for controlled human exposure studies of biomass combustion aerosols as well as other experimental aerosol research. The evaluation included: *i*) the operation principles and function of the chamber under different conditions, *ii*) the generation systems of different types of biomass combustion aerosols. In addition, examples with data from three performed human exposure campaigns was included and discussed as a basis for the evaluation of the whole set-up.
- IV. The objective of **Paper IV** was to elucidate the influence of wood species and combustion conditions on particle emission characteristics in a typical Nordic residential wood stove. The emissions from four different wood species were investigated under two controlled combustion conditions including different burn rates, with a focus on the physical and chemical properties of the fine particulate matter.

- V. The objective of **Paper V** was to gain a better understanding of the formation and occurrence of particulate hydroxylated PAHs from residential log stove combustion using four different wood types at two different burn rates in a common Nordic residential log stove.

- VI. The objective of **Paper VI** was to investigate the influence of burn rate and combustion conditions on emissions of PAHs and organic aerosols with the use of time-resolved PAH measurements combined with gas emission measurements from a conventional wood stove and an adjusted pellet stove.

- VII. The objective of **Paper VII** was to investigate the influence of ozone-initiated ageing and combustion conditions on the physicochemical and toxicological properties of particulate emissions from two distinct combustion conditions from small-scale biomass combustion.

2. Particle formation and characteristics

Particle size is an important parameter that largely determines the behaviour of the particles. The PM is generally classified into different size modes: nucleation mode with particles smaller than 100 nm, accumulation mode with particles from 100 nm to 1 μm , and coarse mode with particles larger than 1 μm . The particles below 1 μm are here defined as fine particles while the fraction below 100 nm is sometimes in the literature defined as ultra-fine particles (UFP). The definition of fine particles is in some forums also set as PM below 2.5 μm . The dividing line between fine and coarse mode at 1 μm is here used because of the better conformity with the formation mechanisms [45].

When measuring particles, the terms UFP (particles smaller than 100 nm), PM_1 (particles smaller than 1.0 μm), $\text{PM}_{2.5}$ (particles smaller than 2.5 μm) and PM_{10} (particles smaller than 10 μm) are commonly used. The smallest particles usually have a higher number concentration, but these particles do not generally contribute significantly to the total PM mass. Coarse particles have the opposite influence on mass- and number distributions, i.e. being fewer while contributing to a large part of the total mass.

In **Figure 2**, different typical particle size modes are shown, as well as the underlying particle formation and growth mechanisms. Examples of particles in the coarse mode are crustal materials, windblown dust and large salt particles from sea spray as well as some anthropogenic particles such as mechanically generated particles from agriculture, surface mining and road dust.

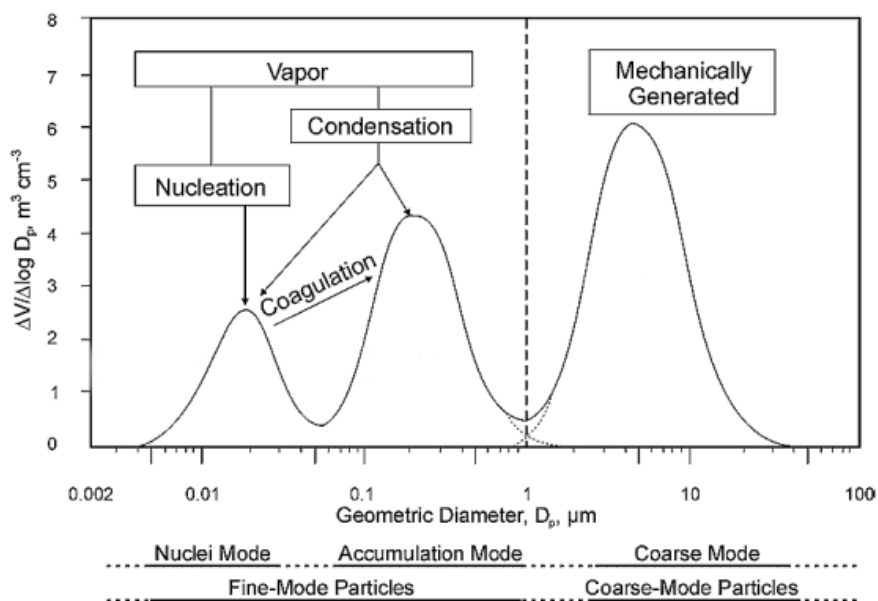

Figure 2. Illustration of the different particle size modes and formation pathways. Reprinted from Wilson and Suh [46].

Nucleation is the formation of new particles from supersaturated vapours of low volatile gas phase species that collide and form molecular clusters. When these clusters are growing faster than they dissociate they eventually become large enough to form a stable particle nucleus. There are two primary types of nucleation: heterogeneous and homogenous. During heterogeneous nucleation, the gas phase species condense onto surfaces of particles already present, causing the size of the existing particle to increase while the number concentration is constant. Homogenous nucleation is the process when particles start to form without a pre-existing surface directly from the gas phase. This requires supersaturation without the presence of any pre-existing nuclei to condense on, causing a sudden increase in number concentration.

During condensation, partitioning of species between the gas and particle phases takes place, where this process is dependent on the saturation ratio and the size of the particle (condensation nuclei). Condensation generally occurs at lower saturation than what is needed for homogenous nucleation. Condensation causes changes in the mass concentration, while the total

number concentration is the same. While homogeneous nucleation occurs for a homogeneous aerosol (i.e. same compounds in the gas- and particle phase), condensation processes occur when gases are converted to liquids/solids on the surface of particles of a compound other than the gas phase.

Another important way for the particles to grow is the earlier mentioned coagulation process, where particles collide and are fused into larger particles. This phenomenon occurs because submicron particles generally stick together, and the process is strongly influenced by particle size and number concentration. During coagulation, the mass concentration is constant while the number concentration is reduced. There are two types of coagulation, thermal and kinematic. Thermal coagulation occurs when the driving force for the particle collision is Brownian motion. When motion and collisions are caused by other types of phenomenon such as electrical forces or gravity, it is called kinematic coagulation.

In combustion processes, aerosol particles are in principal formed by all the formation mechanisms described, although the most prevalent mechanisms depend on specific process conditions and fuel composition. The fine mode combustion particles are formed when vapours from devolatilized and thermally converted fuel gases saturate and are able to form particles by gas-to-particle formation, i.e. nucleation and condensation. After the primary formation, the particles emitted may grow even further by secondary condensation and coagulation processes.

The reason why particle size is such an important parameter to consider, is because the health effects of inhaled particles are thought to depend on factors such as deposition site and their clearance rates which is largely governed by size, but also on their hygroscopicity (ability to take up water) [29, 47]. In general, the larger particles are deposited in the upper lung regions, while smaller particles have a high probability of penetrating and then being deposited in the alveolar region lower down in the lung [48]. This is illustrated in **Figure 3** where particle size is correlated to the deposition efficiency in the human respiratory tract regions.

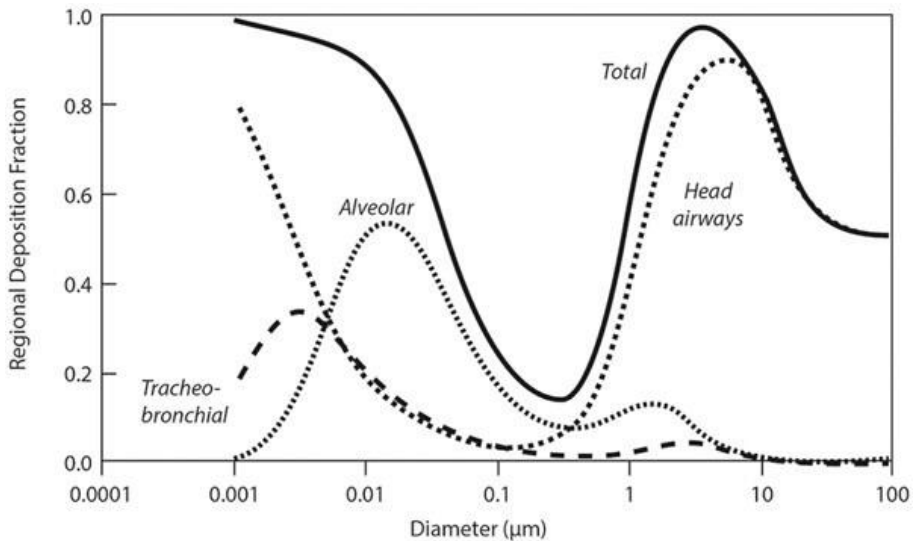

Figure 3. Predicted total and regional deposition fraction correlated to particle size during light exercise and nose breathing according to International Commission on Radiological Protections model. Reproduced from Kuempel et al. [49].

Biomass particle formation

Considerable research efforts have been made during the last 15–20 years into categorizing particle types in biomass combustion processes. A conceptual model including three main particle types was proposed by Bolling et al, including soot (elemental carbon agglomerates), spherical organic carbon particles and inorganic ash particles [29]. This model was recently revised within a position paper that added more complete information on particle size distributions by type as well as new findings in biomass combustion particle formation and dynamics [50]. PM emissions from residential wood combustion have been shown to be totally dominated by particles in the sub micrometer size ($< 1 \mu\text{m}$), i.e. fine mode particles [29, 45] and the formation pathways have for biomass been summarized in a number of publications, e.g. in the thesis by Sippula as shown in **Figure 4** [51]. In the figure, an illustration of the formation routes of both the different types of fine particles as well as coarse particles, is shown.

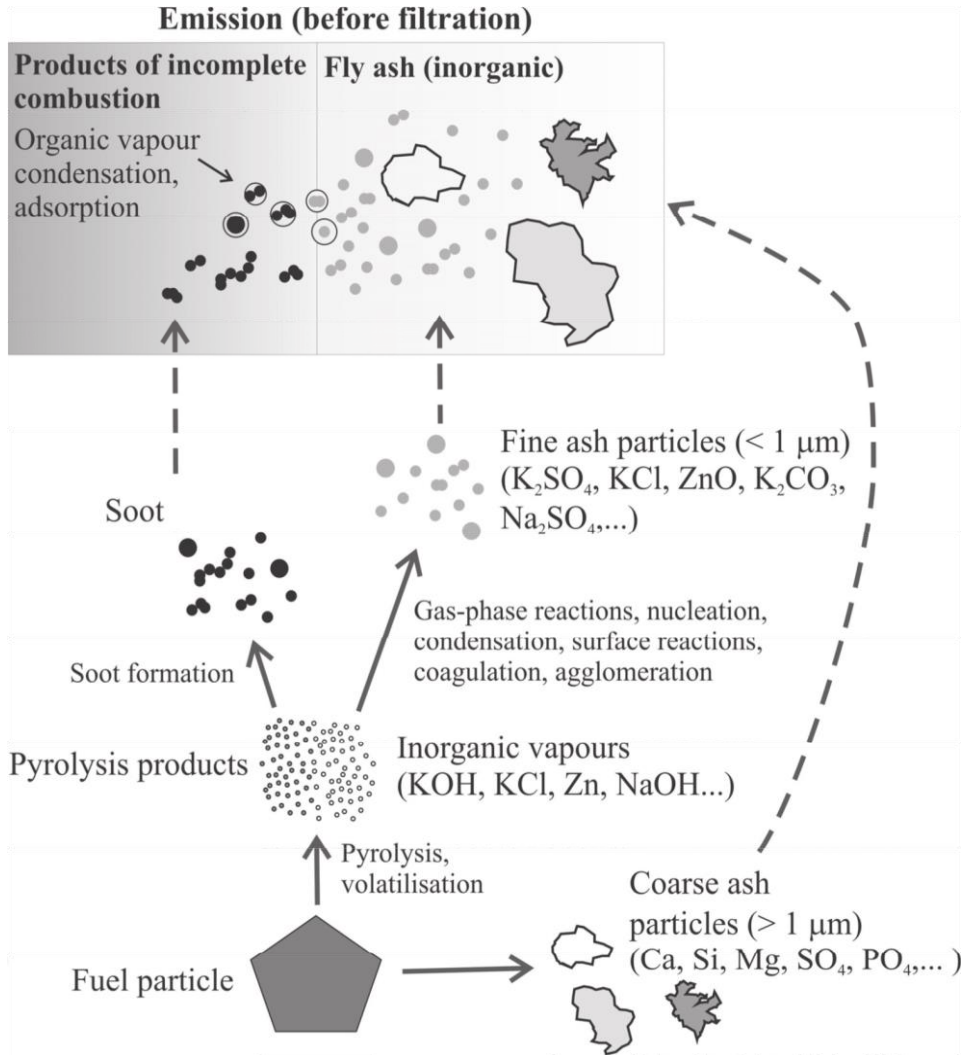

Figure 4. Particle formation in wood biomass combustion as summarized by Sippula [51].

Diesel particle formation

Similar to biomass PM emissions, diesel exhaust emissions consist of a complex mixture of inorganic and organic components both in the gaseous and particulate phase. In addition, the major part of the diesel PM mass consists of fine particles smaller than $1.0\ \mu\text{m}$ with the highest number concentration in the UFP range (below $0.1\ \mu\text{m}$) [52]. A similar conceptual model as for biomass has been presented for diesel exhaust PM, although based on considerably more research data. It states that diesel PM consists of: i) nucleation mode particles composed of condensed HC and sulphates, ii) agglomerates of primary carbon particles, and iii) traces of metallic ash coated with condensed heavier end organic compounds and sulphates. The size distribution is characteristically bimodal with different properties that indicate different origins, i.e. nucleation mode particles and soot; this model is shown in **Figure 5** [53].

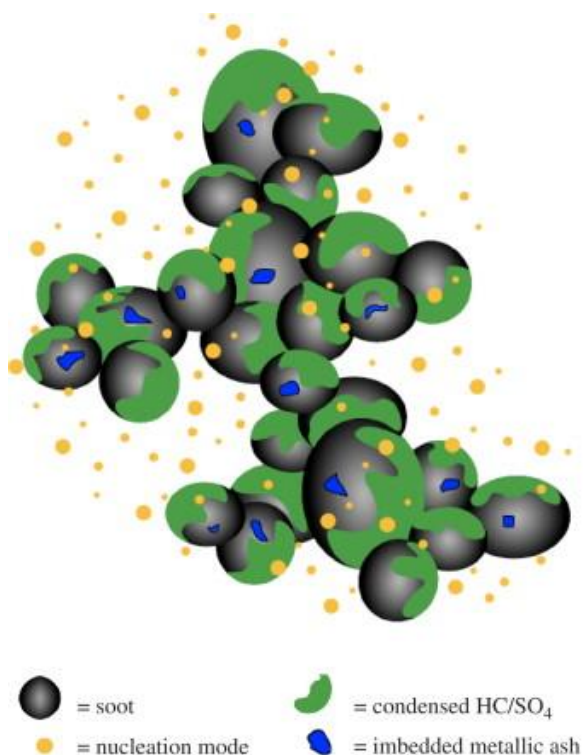

Figure 5. Conceptual model of diesel soot as described by Maricq [53].

The effect of dilution on particle formation

When sampling aerosols from hot gases, as in combustion processes, dilution is often required in order to meet the specific sampling conditions needed, e.g. mass and number concentration, temperature and moisture content. These requirements vary considerably between different on-line and off-line methods. Other reasons for dilution are to simulate ambient conditions and obtain relevant conditions for exposure studies (e.g. when working with human exposure and dosimetry studies). As the nucleation process is very sensitive to the specific conditions (temperature and concentration) during cooling and dilution, care has to be taken when designing the sampling system to obtain reproducible results. In addition, semi-volatile components can exist both in the gas and PM phase during ambient conditions, and their partitioning between the two phases is often rather sensitive. This requires thorough considerations beforehand, especially since excess dilution also can be a problem as it can cause already condensed semi-volatiles to re-evaporate from the particles [54].

In a review by Burtscher, a schematic illustration (**Figure 6**) of how dilution of aerosols can affect particle formation is shown [55]. Two pathways are described, the first one (solid line) is a commonly used two-step dilution, and the second one (dashed line) is when hot dilution is used. With the two-step dilution approach, the temperature is reduced while the dilution ratios are moderate, i.e. conditions that are favouring particle formation by nucleation during supersaturation conditions (the grey area). If using hot dilution, the concentration of volatile material is reduced (i.e. reduced partial pressure) while maintaining a high temperature until a level is reached where no more supersaturation occurs and the gases are then allowed to cool off. The difference between the pathways is that, when supersaturation has occurred, even after the use of a following secondary dilution step, the nucleated and condensed material may still remain in the particle phase.

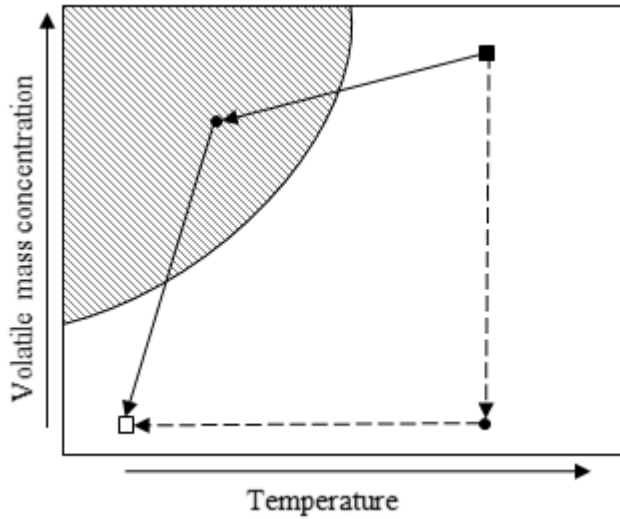

Figure 6. Illustration of how different dilution methods influences the total volatile mass concentration (both gas and particle phase). The grey area is conditions with supersaturation where condensation and nucleation will occur, the white is without supersaturation. The dashed line is representing direct hot dilution while the solid line represents any two-step dilution. The figure is adapted from a review by Burtscher [55].

3. Composition of combustion particles

The particulate matter in emissions during combustion can generally be characterized as either carbonaceous or inorganic material. The inorganic material derives from non-combustible components in the fuel, i.e. major ash components and trace metals. The carbonaceous material derives from unburned fuel components, and can be divided into organic (OC) or elemental carbon (EC). The organic part of the PM emissions can then be even further categorized into primary and secondary organic particles. The primary is, as the name implies, the PM that is emitted directly from the source, while the secondary is PM formed during atmospheric “ageing” of primary PM, where chemical reactions in the gas phase lead to condensation of organic material on existing particles [47]. These processes may include nucleation, condensation as well as heterogeneous and multiphase chemical reactions involving thousands of complex reactions [56]. The terminology primary organic aerosol (POA) and secondary organic aerosol (SOA) are also used in this research area.

During biomass combustion, the largest emissions of POA are during low temperature conditions. This occurs because the pyrolysis products released are not fully oxidized before they leave the combustion zone and are released as PIC. It has also been shown that POA can be released a short while after fuel addition during batch-wise biomass combustion [29]. POAs from engines on the other hand mainly originate from hydrocarbons that have not been oxidized in the engine. It has been shown that these particles are mainly originating from the used lubricating oil, with minor contributions from unburned fuel, oxidized organic combustion products, and sulphuric acid [57].

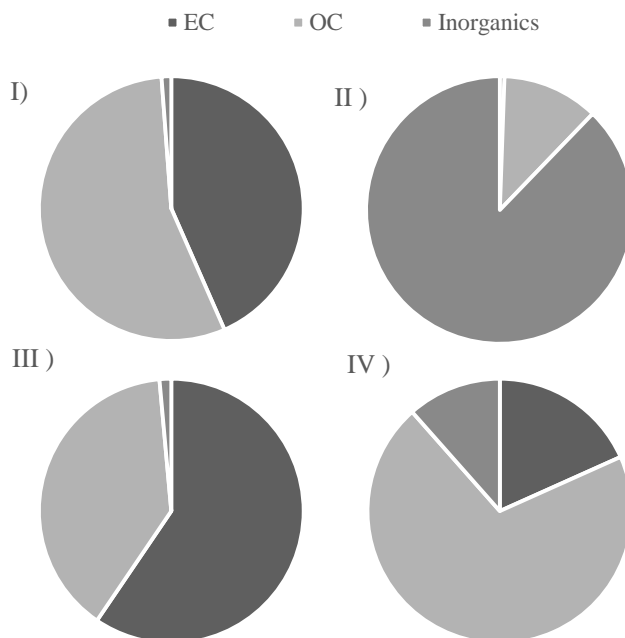

Figure 7. Examples of PM composition from different sources; I) Incomplete wood combustion in a stove, II) Optimized (efficient) wood pellet combustion, III) Passenger car running on standard diesel, and IV) Passenger car running on biodiesel. Plotted with values taken from Lamberg et al. (wood and pellet data) [49], Cheung et al. (diesel and biodiesel data) [50]

As the combustion process and fuel influences the PM emitted, there are large variations between sources. In **Figure 7**, the relative emission profile from incomplete log combustion (I), optimal pellet combustion (II) and a passenger car fuelled first with diesel (III) and then biodiesel (IV) is shown. The relative abundance of each component is strongly affected by the combustion conditions, and thus the equipment used. In most cases when using a wood stove or a similar appliance, the carbonaceous emissions dominate. When this is not the case, such as when combusting pellets under optimal conditions, a major part of the PM emissions consists of inorganic components.

Carbonaceous particles

When the volatilized fuel components are not fully oxidized in the gas phase, as discussed earlier, carbonaceous matter may form soot and fine organic particles in the emissions. One way of classifying the carbon in the PM is by its thermal properties where two fractions are derived, i.e. elemental carbon (EC) and organic carbon (OC). The terms EC and OC do not have a strict definition; instead they are dependent on the analytical technique and analysis protocol used. Furthermore, the detailed relation between the analytical measures (chemical, thermal-, optical properties, etc.) and real life properties of different aerosols, is an on-going scientific discussion [58, 59].

Soot and elemental carbon

Soot is fractal like fine particulate agglomerates formed at high temperature consisting mainly of carbon. When the combustion conditions are optimal with sufficient temperature, air to fuel ratio and residence time inside the combustion zone, the primarily formed soot is almost completely combusted. However, in many practical applications this is not the case, and it is emitted into the atmosphere. The “black smoke” exhaust emissions from an older diesel truck is a good example of a soot rich exhaust emission. The formation mechanism of soot is very complex and has been extensively studied for a long time [60], but formation via polycyclic aromatic cluster formation, particle inception, surface growth and coagulation (i.e. particle-particle collisions) has been described by Bockhorn [61]. The complex formation of particles during combustion of various fuels is depending on fuel type and combustion conditions, this is illustrated in **Figure 8** where primary carbonaceous particles from three different sources is shown. A comparison between both soot in engine exhaust (a) and wood smoke (d), as well as between sooty wood smoke (d) and low temperature smoldering wood combustion (g) is shown.

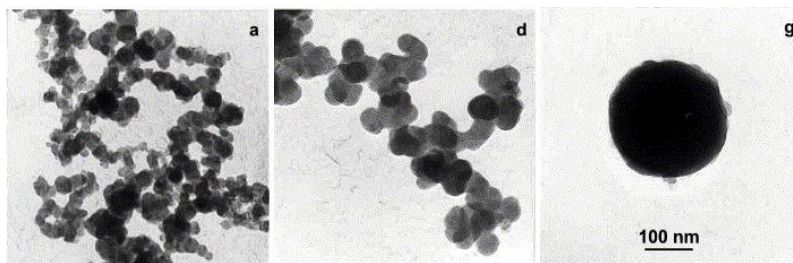

Figure 8. Images of carbon aggregates from (a) vehicle exhaust, (d) wood smoke and (g) a spherical carbon particle from low-temperature wood smoke. Adapted from Kocbach et al. [62].

Although soot is often denominated as EC in the present research work, it is important to remember that it also contains other elements (e.g. hydrogen and oxygen). In addition, the organic coating on the surface of the soot particles can, depending on the analytical procedure applied, also be included in the soot fraction.

In the literature, the terms EC, black carbon (BC) and soot are sometimes used interchangeably [63], but there are some differences between them. EC actually refers to the thermal properties and is commonly used in carbon fractioning as the more refractive carbon (thermally stable) in e.g. air pollution and emission studies. BC on the other hand is defined by the materials' optical properties, defined as an ideally light absorbing substance composed of carbon [64]. In addition, the term soot is used by the Intergovernmental Panel on Climate Change for any combustion-generated aerosol with light-absorbing properties [65].

Organic carbon

Organic carbon (OC) in PM emissions from combustion is generally composed of more or less oxidized organic substances released from the fuel during the combustion process. These compounds often have composition and properties similar to components originally present in the fuel, and may in some cases (using liquid fuels) even be evaporated fuel. OC is to different degrees volatile and thus very temperature-dependent, with many compounds existing in both the particle and gas phase at ambient temperature. When using the standard thermo-optical analysis

method (described later in this thesis), only the carbon content of the organic matter is determined. Thus, by excluding e.g. O, H and N in the fractionation analysis, the procedure does not account for the actual total particulate organic matter (POM). But, with the use of a conversion factor and the OC values it is possible to estimate the POM. A conversion factor of 1.8 has been suggested for wood smoke [66], and for fresh diesel exhaust a conversion factor of 1.4 has been proposed [66, 67] although for biodiesel, a somewhat higher factor should probably be used.

From an environmental health perspective, an important part of the organic matter in combustion emissions is species such as polycyclic aromatic compounds (PACs). Although, PACs are a minor part of the total organic emissions, they are of considerable concern. Among these, PAHs have been most widely studied, as they are known to be both toxic, mutagenic and carcinogenic [59, 68]. However, other less studied PACs may also be of toxicological importance. For example, the oxygenated PAHs (oxy-PAHs) are suspected to be significant contributors to the oxidative stress caused by air PM, and they are also known to have other toxic effects [69, 70]. In some cases, the oxy-PAHs show higher toxicity than the PAHs from which they have been derived [71, 72].

PAHs are hydrogens and carbons structurally arranged as a honeycomb-like ring systems with two or more fused aromatic rings. They are a soot precursors often co-emitted with soot, either in the gas phase or as coating on the emitted soot particles. The distribution between gas and particle phase is determined by the size of the specific PAH. The smaller PAHs with two or three rings are most likely found in the gas phase and the larger PAHs are because of their lower vapour pressure often found in the particle phase in ambient air.

The formation mechanism of PAHs is, however, not yet fully understood, but has been suggested to involve both pyrolysis and pyrosynthesis. During periods of pyrolysis, the combusted organic material is broken down into smaller species, mostly free radicals, which can then fuse to form simpler PAHs through pyrosynthesis. These simpler PAHs can then by further pyrosynthesis form larger ring systems [73].

PAHs are classified by both the United States Environmental Protection Agency (EPA) and the European Union (EU) using a system with priority lists of PAHs (**Table 1**). The lists include PAHs that are due to their wide

distribution and toxicity of special concern for the environment or for human health. Among the PAHs on the lists only benzo[a]pyrene is classified as a human carcinogen (Group 1), but several are classified either in Group 2A (probably carcinogenic to humans) or Group 2B (possibly carcinogenic to humans) by the International Agency for Research on Cancer (IARC).

It has been estimated that residential and commercial biomass burning accounted for 60% of the global emissions of the 16 PAH on the EPA list during 2007. In addition, on-road vehicular tail-pipe emissions accounted for 13% while agricultural waste burning, deforestation, and wildfires accounted for 14% [74].

Table 1. PAH compounds included in EPA 16 PAH and EU 15+1 priority lists and their classification according to IARC.

PAH compound	EPA 16 PAH	EU 15+1	IARC Classification
Naphthalene	X		Group 2B
Acenaphthylene	X		-
Acenaphthene	X		Group 3
Fluorene	X		Group 3
Phenanthrene	X		Group 3
Anthracene	X		Group 3
Fluoranthene	X		Group 3
Pyrene	X		Group 3
Benzo[<i>c</i>]fluorene		X	Group 3
Benz[<i>a</i>]anthracene	X	X	Group 2B
Chrysene	X	X	Group 2B
Cyclopenta[<i>cd</i>]pyrene		X	Group 2A
5-Methylchrysene		X	Group 2B
Benzo[<i>b</i>]fluoranthene	X	X	Group 2B
Benzo[<i>k</i>]fluoranthene	X	X	Group 2B
Benzo[<i>j</i>]fluoranthene		X	Group 2B
Benzo[<i>a</i>]pyrene	X	X	Group 1
Dibenz[<i>a,h</i>]anthracene	X	X	Group 2A
Indeno[1,2,3- <i>cd</i>]pyrene	X	X	Group 2B
Benzo[<i>ghi</i>]perylene	X	X	Group 3
Dibenzo[<i>a,e</i>]pyrene		X	Group 3
Dibenzo[<i>a,l</i>]pyrene		X	Group 2A
Dibenzo[<i>a,i</i>]pyrene		X	Group 2B
Dibenzo[<i>a,h</i>]pyrene		X	Group 2B

Group 1: Carcinogenic to humans, Group 2A: Probably carcinogenic to humans, Group 2B: Possibly carcinogenic to humans, Group 3: Not classifiable as to its carcinogenicity to humans.

Inorganic particles

The inorganic part of the PM from combustion sources can be derived from major ash-forming matter in the fuel, trace metals in the fuel, fuel/combustion additives, and residues from different materials/process steps (fuel and appliance/engine related). All of these types of particles are used as a nominator for the non-organic part found in the PM, although often summarized as inorganics in this thesis.

During biomass combustion, the fine inorganic PM emissions are formed from components in the fuel itself by release of volatilized inorganic elements during combustion and then formation of particles as the temperature drops in the flue gases. The part that is released can commonly be called fine fly ash, but there is also another group of inorganics called the bottom ash. It consists of the inorganics which are too large to follow the gas stream, therefore staying in the combustion zone, and thus not co-emitted with the particles. As these inorganics are part of the fuel itself, it is not possible to reduce them by improving the combustion efficiency. The major part of the fine inorganic emissions from biomass combustion is usually dominated by salts from alkali metals (primarily potassium and to minor extent sodium), often in the form of chlorides, carbonates and sulphates, together with a minor part of zinc (Zn) [30, 51, 75]. A varying part of the potassium (K) in the fuel can be volatilized during combustion, depending on the overall ash transformation chemistry which, in turn, depends on the fuel composition and combustion process [76]. In general, the amount of alkali metals in the biomass may give a first estimation of the potential for forming fine ash PM during combustion, although this is not fully applicable in all cases [76, 77]. For woody fuels in general, the content of trace metals is very low, and the only relevant trace element involved in fine PM formation is Zn that can contribute with up to maximum a few percent of the total fine PM. For other biomasses, e.g. agricultural fuels and different residues, increased levels of other trace metals can also be found [78, 79].

For engines, the formation routes and characteristics of inorganic fine particles are somewhat different compared to solid biomass combustion. When using SD in engines, it seems like Fe, Mg, Ca, Cu, and Zn are the major inorganic metal species emitted [80]. In another study, SD emissions were compared with BD, and it was found that in BD particles the content of Zn, Cr, and Ni increased, while As, Co, Al, and Mn decreased [81]. The

study was performed using a diesel back-up power generator at fixed engine operation points. The different metal species found in the exhaust PM can originate from different sources and end up in the PM either as metallic ash adhering to soot particles or by new particle formation via nucleation. Elements such as Ca, Zn, P, Mg, S, Na, Al and K have been found to originate from the lubrication oil, while Fe, Cr, Ni, Sn, Al and Sb have been found to originate from engine wear and/or corrosion [82].

4. Materials and methods

Wood stove setup and fuels

The combustion setup used for generation of wood smoke exhaust in **Paper III–VI** consisted of a typical Swedish/Nordic 9 kW wood stove that has been modified to be operated in a laboratory setup enabling controlled combustion and sampling conditions. The modification enables monitoring of the amount of air that enters the stove by the use of a mass flow meter; numerous thermocouples both in the combustion zone and throughout the flue gas channel; monitoring of the under pressure in the system and a number of easy-access ports in the flue gas channel for both gaseous and particulate sampling.

The main difference between this setup and a log stove commonly used in the home is the ability to control and maintain a constant under pressure in the chimney. This is achieved by the use of a flue gas fan and a pressure meter. The under pressure and air flow through the combustion chamber in a small-scale appliance is normally determined by the natural draught in the chimney. The extent of the draft is mainly influenced by flue gas temperature, mass flow and ambient temperature. However, this causes variability both between a “cold” and a “warm” setup and other factors that cannot be controlled (e.g. weather). To be able to compare and obtain reproducible results from different experiments performed during different days, the setup is therefore operated at fixed under pressure points. In this thesis, the amount of under pressure that have been used during all wood stove papers (III–VII) was set to 10–15 Pa, to comply with the authentic range during normal household usage.

In **Papers IV and V** four different wood log types (tree species) were used, i.e. birch, aspen, spruce and pine, all commonly found in the Nordic countries. In **Papers III, VI and VII**, birch was the only type of log used. All logs used were from trees growing in the vicinity of Umeå in northern Sweden and were stored outside under a roof for at least one season to give as representative a wood fuel as possible regarding moisture (12-18 %). Mouldy and obviously deteriorated and “contaminated” logs were discarded.

Diesel engine setup and fuels

The diesel engine used in **Papers I and II** was an engine produced between 1996 and 2004, meeting emission class EU Stage I and Tier 1 for non-road engines (9.2 g/kWh NO_x and 0.54 g/kWh PM). It has a flat power curve at 74.6 kW, 2200 rpm and 4 cylinders and 4-litre displacement with mechanical distributor pump and direct injection. This older type of engine is not fitted with a diesel particulate filter.

The engine was connected to an engine dynamometer controlled by computer program running the European Transient Cycle (ETC) or at constant idling mode. The ETC cycle is a standardized running protocol used to test engines and vehicles during transient conditions, mimicking real-life running situations. It is based on recordings of accelerations and retardations, with variations in engine load and speed. It contains frequent starts, stops and idling running and a maximum speed of 50 km/h. In combination with the European Stationary Cycle, the ETC cycle is used for emission certification of heavy-duty diesel engines in Europe. The ETC protocol originally includes three different sections, i.e. urban, rural and motorway conditions. In this thesis (**Paper I and II**), only the urban part of the ETC cycle has been used.

Three different fuels/fuel blends were used in **Paper I**; i) SD composed of 100 wt-% low-sulphur standard petro diesel, ii) B100 composed of 100 wt-% rapeseed methyl ester biodiesel, and iii) B30 composed of a fuel blend of 30 wt-% RME and 70 wt-% SD. In **Paper II**, only pure SD and BD100 were used. Both the RME and the standard petro diesel were delivered by Preem AB, Sweden. The RME used contained the fuel additive ACP (Active Cleaning Power) as a standard in the product, with the aim to improve combustion and reduce engine corrosion.

Wood smoke chamber set-up

In **Paper III** a walk-in whole body exposure chamber (2.7m x 2.35m x 2.4m = 15.3m³) was described and evaluated. This set-up has the main purpose of facilitating human exposure studies of biomass combustion emissions, but can also be used for other purposes, preferably in experimental aerosol research. The chamber was also used in **Papers VI and VII** as an equalizing volume to enable specific sampling conditions. It is constructed with all interior surfaces made of sheets of stainless steel and supporting beams of aluminium and panels of glass. The materials were chosen for their property of being inert and also for not building up

localized electric surface charges, and are thus suitable for experiments with gases and particulate emissions. The panels of glass are incorporated both to let in light and to allow visual observation by the medical and technical personnel on the outside, as well as to limit the sensation of claustrophobia and unease during the stay in the chamber. The chamber is entered via an ante-chamber, this in combination with a slight overpressure inside the chamber, ensures that the atmosphere in the chamber is not influenced by the surrounding environment.

The airflow into the chamber is first treated in the main ventilation system where the temperature set point is 18°C and a first filtration is performed. The extracted partial flow intended for the chamber is then passed through an additional cleaning stage consisting of an active carbon filter (AFP AZ Process, Vokesair) and high efficiency particulate arresting (HEPA) filter (Compatex FP H13, Vokesair). The chamber is designed for a continuous air flow at an exchange rate of 2–10 times per hour. The air velocity and temperature is measured with a hot-wire anemometer system before it enters the chamber. Before the clean airflow enters the chamber, premixing of exposure aerosol occurs. A partial flow of the biomass combustion emission is injected counter-current into the airflow so as to ensure good mixing, and is then carried further into the chamber where it enters at roof level.

Inside the chamber, a wide number of parameters are monitored depending on study design requirements, e.g. NO_x, CO, THC, temperature, relative humidity and online PM₁ particle mass concentration. Particle mobility size distribution and number concentration can also be measured on-line with an SMPS system (described below). In addition, more advanced and specific gas or particulate measurements may also be applied from case to case.

Sampling, instrumentation and on-line analysis

Total particle mass sampling

To determine the total PM mass concentrations, standard dust sampling equipment and procedures were applied following Swedish Standard SS-028426 where possible. The standard dust sampling method consisted of a filter holder with dual glass or quartz fibre filters ($\varnothing = 90$ mm) followed by gas cooling, a gas flow meter and a pump. The filters were stored in a desiccator for conditioning before weighing prior to and after sampling of PM. In **Paper IV** the filters were used only for gravimetric mass

concentration determination, while in **Paper V** they were also used for oxy-PAH analysis.

Gravimetric Impactor

In **Papers IV and VII** a high sample flow rate cascade impactor designed for measuring the gravimetric particle size distribution of particles (DGI-1570, Dekati Ltd., Tampere, Finland) was used to sample particles. It is designed to have impaction cut points at 2.5, 1.0, 0.5 and 0.2 μm when operated at a flow-rate of 70 L min^{-1} . Filter substrates used were four 47mm PTFE Membrane filters (Capitol Scientific Inc., Austin, TX, USA) with a last 70 mm PTFE Membrane backup filter (Capitol Scientific Inc., Austin, TX, USA). The DGI filter samples collected in **Paper VII** were used for subsequent chemical and toxicological analysis of the PM material while in **Paper IV** oxy-PAH analysis was performed.

The use of different kinds of gravimetric impactors is a well-established sampling technique where the particles are size fractionated in different classes. The particles are classified according to their aerodynamic diameter, which is defined as the diameter of a spherical particle with a density of 1000 kg/m^3 and the same settling velocity as the irregular particle measured [48]. Since not all particles are spherical nor have this unit density, this measure is not the “true” measure regarding actual size, but rather defines the size related to their aerodynamic behaviour. Inside the impactor, the aerosol passes through a series of impaction stages consisting of nozzles with the collection substrate beneath. When passing through the nozzles, the particles’ inertia is then forcing the particles, of a given size for each stage, to stick to their original linear path and they will, therefore, impact instead of following the gas stream, as illustrated in **Figure 9**.

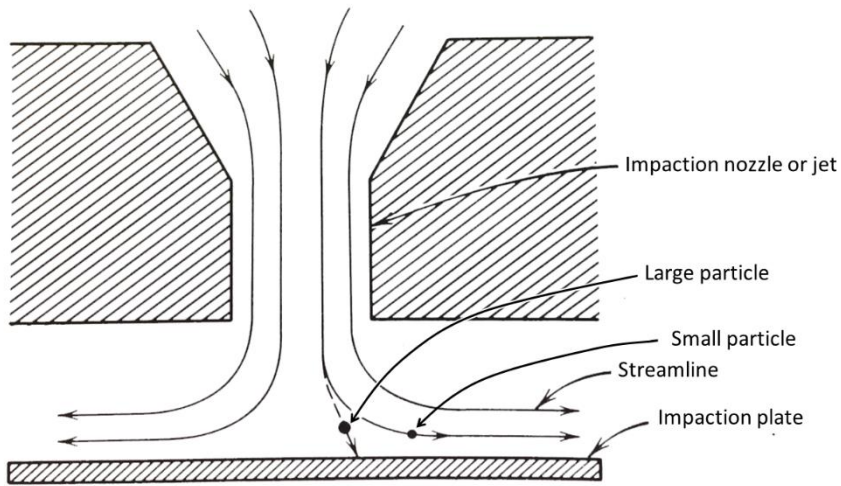

Figure 9. Schematic illustration of how an impactor works, as published by Hinds [48].

Scanning mobility particle sizer system

In **Papers II, III and VI** online measurements of particle mobility size distribution and number concentration were performed by using a scanning mobility particle sizer (SMPS) system in order to determine the number of particles of each particle size.

The main parts of an SMPS system consist of a differential mobility analyser (DMA) followed by a condensation particle counter (CPC). The purpose of the DMA is to size the particles according to their electrical mobility equivalent diameter, and the purpose of the CPC is to count the particles continuously. In **Papers III, V and VI** an older SMPS system consisting of a DMA 3071A and a CPC 3010 was used. In **Papers IV** a more modern SMPS system consisting of Electrostatic classifier 3082 equipped with DMA 3081 in combination with CPC 3775 was used instead, enabling shorter scan times. All equipment was bought from TSI Inc. (TSI, Shoreview, MN, USA).

An SMPS system works by the principle that a particle of a specific size holding a charge will traverse an electrical field according to its electrical mobility. Inside the DMA, a variable electrical field is created which

enables the selection of a specific particle size by the ability to direct these particles towards a port leading to the CPC where all particles are counted. By varying the electrical field and thus the size of the particles that pass the DMA, it is possible to achieve a number concentration for each particle size during a specific time (scanning) period. An example of a typical SMPS scan where a certain size range – set by the voltage range, scan time and flow rate conditions – is plotted against concentration, is seen in **Figure 10**. Most aerosols have some electrical charge and as the SMPS relies upon the particle charge to be able sizing, it is crucial to have a well-defined charge level. With the use of a bipolar charger it is possible to achieve a size-dependent equilibrium by generating both positive and negative ions which, by diffusion, interact with the particles and exchange charges before they enter the DMA.

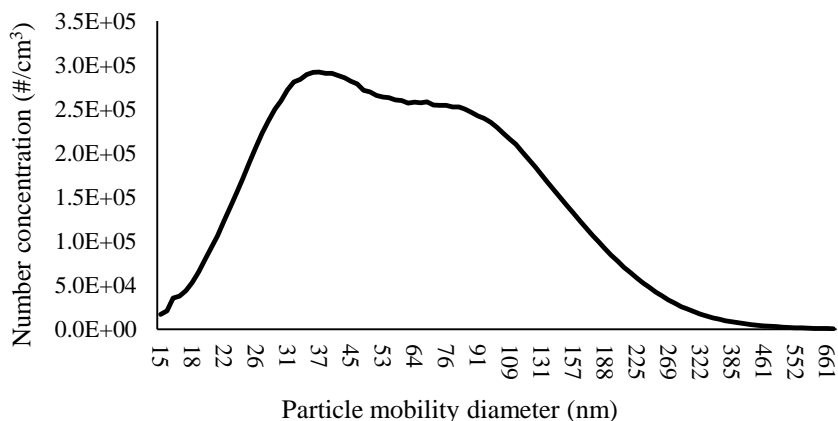

Figure 10. Example of a SMPS scan (of biodiesel exhaust), the particle concentration (y-axis) plotted against the particle size (x-axis).

The CPC detects (count) single particles optically by light scattering. To allow easy detection of even the smallest particles with the use of optical means, the particles need to be in the size range of 5-15 μm . This is achieved by letting the aerosol pass through a saturated n-Butanol or water vapor (depending on what kind of CPC is used) that, combined with cooling, makes the particles grow by condensation of the liquid on the particles. In an SMPS system, the particles entering the CPC are monodispersed based on the DMA classification, thus enabling the measuring of particle concentrations of specific size classes.

Differential mobility spectrometer

Another instrument that also measures particle mobility size distribution and number concentration is the differential mobility spectrometer (DMS). The DMS is based on the same size classification principles as the DMA; however, the instrumental set-up is somewhat different and designed with the overall feature to enable fast measurements in transient aerosol conditions instead of the long scan times needed with the SMPS. A DMS was used in **Papers I and II**. The DMS here was a DMS500 Fast Particle Analyzer (Cambustion Ltd., Cambridge, UK). In the DMS, a unipolar corona discharge is used, placing only a positive charge proportional to particle size, instead of the bipolar diffusion charger used in the SMPS system. After the particles are charged, they enter a strong radial electrical field inside a classifier column. Depending on the particles' electrical mobility (same as for SMPS), they are transported differently in this field. The main difference compared to SMPS is that, inside the column of the DMS, 22 electrometer detectors are placed that detect when a particle lands on them and the particle charge is conducted to ground. Smaller particles are more mobile and are, therefore, transported to the early detector stages while larger particles are able to travel further down.

Aerosol mass spectrometry

In **Paper VI**, a high resolution time of flight aerosol mass spectrometer (AMS) was used (HR-ToF-AMS, Aerodyne Research Inc.) [83] for time-resolved information on organic particulate matter (OA) and the subcategory PAHs, separated into groups by molecular weight. The AMS system can be divided into three main components: aerosol inlet, particle sizing chamber, and mass spectrometer. The sampling flow into the instrument is created by keeping a vacuum inside the instrument.

The AMS applied in this research uses time of flight (ToF) to determine the particle vacuum aerodynamic size. The non-refractory PM is flash vaporized by the use of a Tungsten plate, heated to 600 °C and the vapours produced are ionized by electronical ionization producing positively charged molecular fragments, which are then extracted in the ToF-MS. In the ToF-MS, the mass (atomic units) to charge ratio of the fragments is determined; it is the intensities of the different mass to charge ratios which forms the actual mass spectrum.

In most studies performed in this area of research, PAH emissions from wood stoves and engines have traditionally been measured with filter-

based methods where the PM collected is analysed with GC-MS or other off-line techniques [31, 84]. This has some advantages as the detection limit is really low and it is possible to distinguish between isomers. However, together with the development of advanced on-line aerosol instrumentation, new possibilities have occurred. When using the AMS, time-resolved data is available giving new information about emissions linked to specific combustion conditions. This method to detect and quantify PM PAHs was developed by Dzepina et al [85] with the use of an algorithm that distinguishes the PAHs signals within the mass spectrum.

Gaseous components

In **Papers I, III-VII** online monitoring of the emissions of O₂, CO, NO was measured with electrochemical cells. When measurements were performed in diluted gases, a chemiluminescence technique was used in order to determine NO, NO₂ and NO_x in all papers. In addition, during measurements on diesel exhaust in **Paper II**, a non-dispersive IR technique was used for CO and CO₂, a paramagnetic technique for O₂, while another type of chemiluminescence instrument (with higher maximum measurement range) was used for detection of NO, NO₂ and NO_x. For these diesel exhaust measurements, all instruments were in compliance with the emissions directive issued by the European union.

Dilution systems

In all papers included (**Papers I–VII**) in this thesis, different dilution methods have been used to meet the specific needs for each measured parameter. The most commonly used dilution method applied was, however, a setup consisting of a porous tube diluter (PTD) followed by an ejector dilutor (ED) which has been found to obtain a clear nucleation mode by Lyyräinen et al [86]. A schematic illustration of both a PTD and a ED can be seen in **Figure 11**.

A PTD is in principal a tube that has a second inner porous tube of sintered stainless steel, and it is through this tube the dilution air enters the exhaust flow. In the setup used, the dilution ratio is controlled with mass flow controllers, enabling a wide range of dilutions ratios. An advantage with the PTD is that the dilution air is homogenously fed throughout the tube, while there is no risk of clogging. A drawback is that it does not provide a suction flow; therefore, a pump or another similar device is needed. An ED on the other hand provides a suction flow, but the DR cannot be adjusted

during operation. An ED is also prone to clogging by deposition of coarse particles in the nozzle where the suction is created. The suction is created by forcing clean pressurized dilution gas to flow tightly around the nozzle causing a pressure drop, that pulls the undiluted sample into the diluter.

When the PTD and ED are combined, a system that is both variable does not need an external suction device and is less likely to clog is created, a system that can, therefore, be used in a wide range of exhaust types. Regarding what DR to be used, there is no one correct ratio that can be used. It depends on the specific measurement performed, but is important to know how it influences the results.

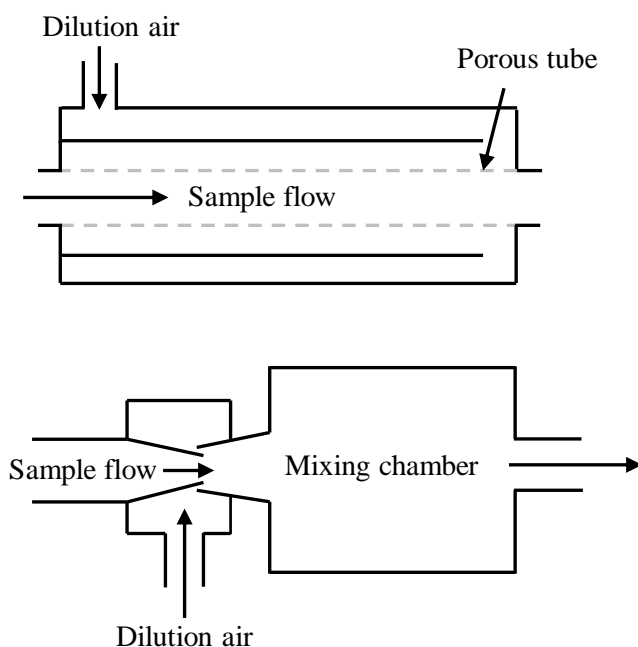

Figure 11. *Illustration of a porous tube diluter (upper) and an ejector diluter (lower).*

In **Paper I** a virtual dilution tunnel (PSS-20, Control Sistem, Turin, Italy) was used. The dilution tunnel is designed to be in accordance with the main European and American regulations for homologation of diesel engines and uses a partial flow method with variable dilution. Dilution was on average 19.1 times (18.1–20.1), given by the fact that the filtered dilution air in and the total diluted gas flow were monitored with flow meters and controlled so that the dilution was maintained for any given second.

In **Paper II** a custom built dilution system was used, shown in **Figure 12**. From the undiluted exhaust emissions, a continuous gas flow is pushed through an overflow pipe, determined by the total exhaust gas flow, into the first dilution point. The dilution ratio in this dilution point is set by a regulating fan, controlling the amount of dilution air that enters from the main ventilation flow. The second dilution point is when this partial flow enters back into the main flow again.

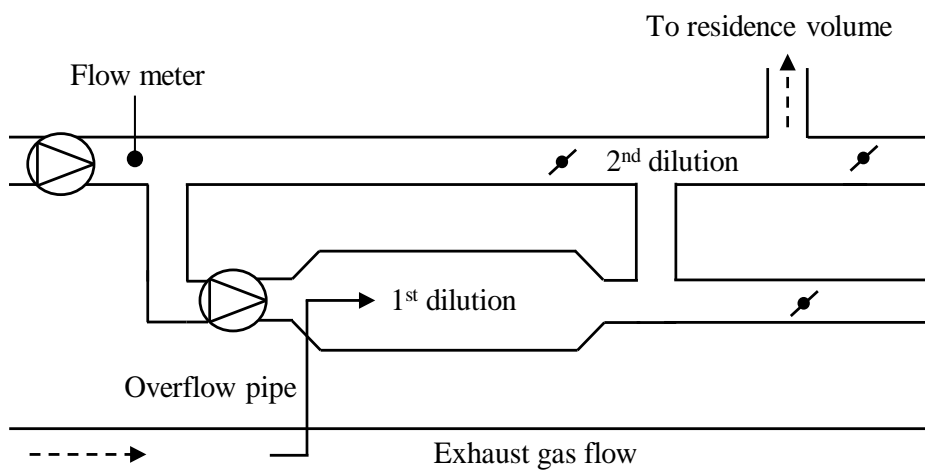

Figure 12. Diesel exhaust dilution setup.

In **Papers III and VII**, a two-step dilution system was used (**Figure 13**). The first dilution step consisted of a porous tube diluter [86] with variable dilution (controlled with mass flow controller) followed by a fixed ejector diluter with approximately one to six dilution. The second dilution was achieved with counter-current flow injection in the main HEPA filtered air flow that enters the chamber. Dilution air was filtered pressurized air at ambient temperature in all but the last step, where filtered ventilation air was used.

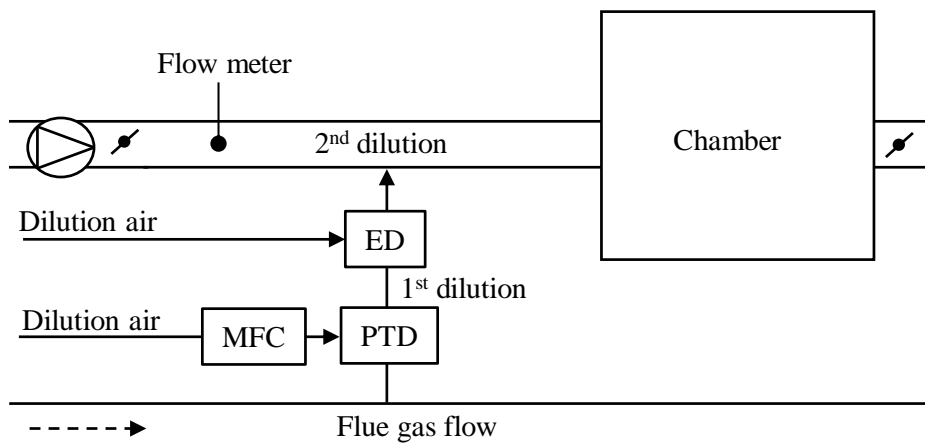

Figure 13. Dilution- and chamber setup for biomass combustion emissions.

In **Papers IV and V**, three different dilution lines were used. In the first sampling line, the sample was diluted in two steps using ejector dilutors (Dekati Ltd., Tampere, Finland) with a dilution ratio (DR) of ≈ 100 times. After dilution, online measurement of particle mobility size distribution and PN was performed using an SMPS as well as sampling for carbon fractioning and PAH. The flue gas in the other two sampling lines were diluted with the use of a PTD in each line, followed by sampling equipment used for collection of PM for oxy-PAH, OH-PAH and PM_{tot} sampling. DR was kept as low as possible (4–70 times) and was determined with the use of MFC supplying the PTD and having a known pump flow.

In **Paper VI** a PTD followed by two ED in series was used to achieve the desired DR.

Chemical (off-line) characterization of PM

In all papers included (except Paper II) different offline filter based analysis methods were used to chemically characterize the particle emissions. These are summarized in this section.

Carbon fractioning (soot and organics)

In **Papers I, IV, VI and VII** thermal-optical carbon fractioning analysis was performed to determine the amount of organic carbon (OC) and elemental carbon (EC). OC is associated with the total organic PM while

EC is associated with the more refractory soot fraction PM. OC+EC gives the total carbon (TC) content of the analysed PM, but the inorganic carbonates are excluded. When using a thermal analysis method, the refractivity of EC is utilized by the fact that EC does not volatilize in an inert atmosphere at temperatures below $\approx 700^\circ\text{C}$. This in combination with that EC can only be gasified in an oxygen environment at temperatures above 340°C gives that OC can be defined as the fraction that evolves under a heating cycle in an inert atmosphere, while EC is the fraction that evolves during a subsequent heating step in an oxygen-containing gas mixture. The gasified carbon is then detected with the use of a flame ionization detector.

The optical part of the analysis has been introduced into the analysis to compensate for charring of some heavier organic compounds during the heating in inert (reducing) atmosphere. This EC (char) fraction is formed because of the analysis method and will incorrectly be reported as EC instead of OC. With the use of continuous monitoring of the optical properties (reflectance or transmittance) of the filter, this charring can be corrected, giving a better split between the fractions.

The carbon fraction analysis described in this thesis was performed according to the EUSAAR 2 thermal protocol at NILU, Oslo, Norway. The protocol is designed to minimize potential positive and negative biases and therefore increases the accuracy of the OC/EC measurements. The EUSAAR 2 protocol is defined as first four steps in He atmosphere and then four steps in He/O₂ atmosphere, each step with different temperatures and residence times. The method and its advantages are described in more detail elsewhere [87].

Polycyclic aromatic hydrocarbons

Sampling of particulate PAHs was performed in **Papers I, IV-VII**.

Determination of PAHs and oxy-PAHs in **Paper I** was performed using an in-house built HPLC/GC/MS system. The same system was used for PAH determination in **Papers IV, V, VI and VII**. In **Paper V**, sampling of PM was done for a newly designed analysis method to analyse OH-PAH utilizing liquid chromatography – photo ionization tandem mass spectrometry system and pressurized liquid extraction. All these analyses were performed by Professor Roger Westerholm's group at Stockholm University.

In **Paper IV**, a gas chromatography-high resolution mass spectrometry was used for oxy-PAH analysis performed at Umeå University by Dr Staffan Lundstedt.

For more information about the individual analysis method and procedure used, see the respective paper included.

In the papers presented, analysis only on the filter samples was performed, thus only the particulate PAHs were analysed. When collecting PM on filters for PAH determination, some systematic errors occur that could be of some relevance. One of the most common errors is caused by the volatilization of semi-volatile organic compounds adsorbed to the PM as well as gas phase components adsorbed onto both PM and filter [58]. This particle/gas phase partitioning is determined by sampling temperature and dilution ratio and is discussed more in the paragraph about dilution.

Inorganic particles

In **Paper IV** determination of major inorganic ions was performed by ion chromatography analysis at IVL – Svenska Miljöinstitutet. With the method used, the filter material was initially extracted in water using an ultrasonic method. Anions (Cl^- , SO_4^{2-} and NO_3^-) were analysed according to SS-EN ISO 10 304-1 :2009 while cations (Na^+ , K^+ , Mg^{2+} , Mn^{2+} and Ca^{2+}) were analysed according to SS-EN ISO 14911:2000, using an anion- and cation Dionex ion chromatography, respectively (Dionex Corporation, Sunnyvale, CA, USA), while in **Paper VII** the analysis was performed at the University of Eastern Finland using another ion chromatograph (IC, Dionex DX-120) system following corresponding methodology.

5. Results and discussion

Paper I

In this paper exhaust emission from an older 4-cylinder non-road engine was investigated. Particles for offline measurement were collected on filters as well as online measurements of gaseous components (i.e., O₂, CO, NO) and particle properties (i.e., PN and particle size distribution) using three different fuels; SD, B30, and B100 while running a modified version of the ETC-driving cycle. Carbon fractionation was also performed to find the EC to TC ratio. In this study, no POM factor was calculated. A total number of 46 PAHs were analysed, including the rarely determined but potent carcinogenic PAHs 7,12-dimethylbenz[*a*]anthracene, 5-methylchrysene and benz[*j*]aceanthrylene as well as four Oxy-PAHs.

When using 100% RME biodiesel, PM and CO were reduced, while a small increase in NO_x emissions occurred compared to SD. BD also showed a lower number concentration with a shift to smaller particles. During idling operation mode, PN and particle size were less influenced by the different fuels. The EC/TC ratio of the particles indicate that B100 particles contain a higher fraction of organic carbon compared to SD and the B30.

B100 produced lower emissions for almost all of the PAHs analysed when compared to SD. Coronene was the only exception, for which B100 had an emission factor 71% greater than that of petro diesel. The total emission factors of all of the PAHs was 46% and 78% lower for B30 and B100, respectively when compared to SD. For oxy-PAHs, SD had the highest emissions for all oxy-PAHs analysed, with the emission factor being 41% and 63% lower than SD for B30 and B100, respectively. Thus, the lowering in emission of PAHs is somewhat greater than of oxy-PAHs when combusting B100. This is illustrated in **Figure 14** which shows the emission factors of PAHs and oxy-PAHs as well as the ratio of oxy-PAHs/PAHs. B100 had a higher ratio (0.55) between the particle associated oxy-PAHs/PAHs than the other fuels, which had a similar ratio (0.32 and 0.35 for SD and B30, respectively). This suggests that B100 particles are more enriched in Oxy-PAH than the particles originating from the combustion of the other tested fuels.

To summarize, it was concluded that the introduction of biodiesel, and potentially other renewable fuels, to existing diesel engines, can result in a considerable change in the exhaust particle properties.

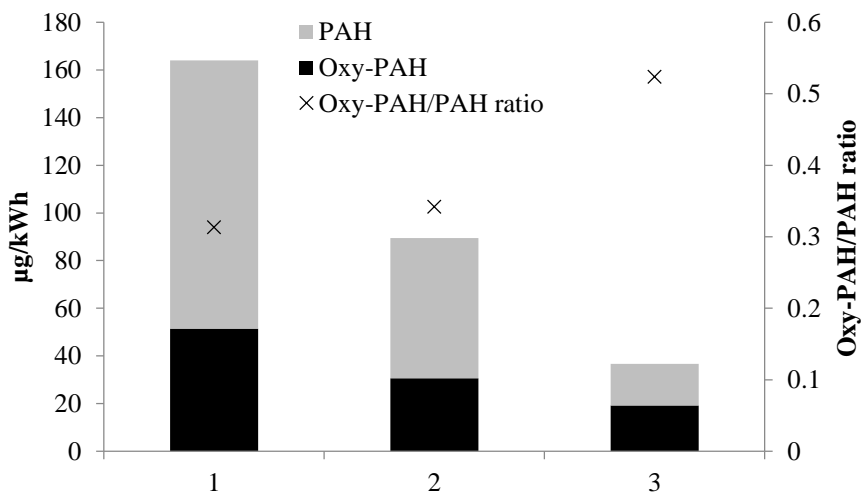

Figure 14. PAH and Oxy-PAH as well as the ratio between them. Adapted from Figure 6 in Paper I.

Paper II

In this paper the effect of dilution on the PM exhaust from an off road engine running on both standard petro diesel as well as RME biodiesel was investigated. The investigation was performed by applying online measurements of particle size distribution and number concentration with a differential mobility spectrometer (DMS) to elucidate differences between: *i*) raw exhaust particles, *ii*) a first dilution step with a dilution ratio (DR) of ~ 7 times, and *iii*) a following third dilution step with a residence time of ~ 10 minutes and a DR of ~ 73 times. While sampling in the first dilution step, the DMS was alternated between using the standard heated line or bypassing this stage and sampling the aerosol directly with the rotating disc diluter inside the DMS. In addition, the influences on the exhaust particle properties of changing the lubrication oil was investigated.

In general, it was found that biodiesel generated more nucleation mode particles (presumably organics) than petro diesel while both the number concentration and the mobility diameter of the accumulation mode (presumably soot) was reduced. When applying sampling with the heated line it was found that nucleation mode particles were suppressed both in the raw exhaust and in the first dilution step (Figure 15). In the first dilution stage more nucleation mode particles was however found than in the undiluted exhaust. This is somewhat surprisingly and can probably be explained by the external cold dilution before the sampling with the DMS. Measurements without the heated line showed that the custom-built dilution setup used in this paper favored generation of nucleation mode particles, which is line with literature data from real outdoor measurements as it has been shown that laboratory measurements often underestimate the nucleation mode particles.

After the oil exchange the nucleation mode in the diluted gases was increased compared to before the exchange. As earlier studies suggest that the nucleation mode consists primarily of heavy hydrocarbons, mainly associated with lubrication oil, perhaps some high end volatility components in the lubrication oil are preferentially vaporized just after the oil exchange, which may explain the large increase in nucleation mode observed in this study. It is thus possible that the higher lubrication oil emissions could decrease after some operation hours.

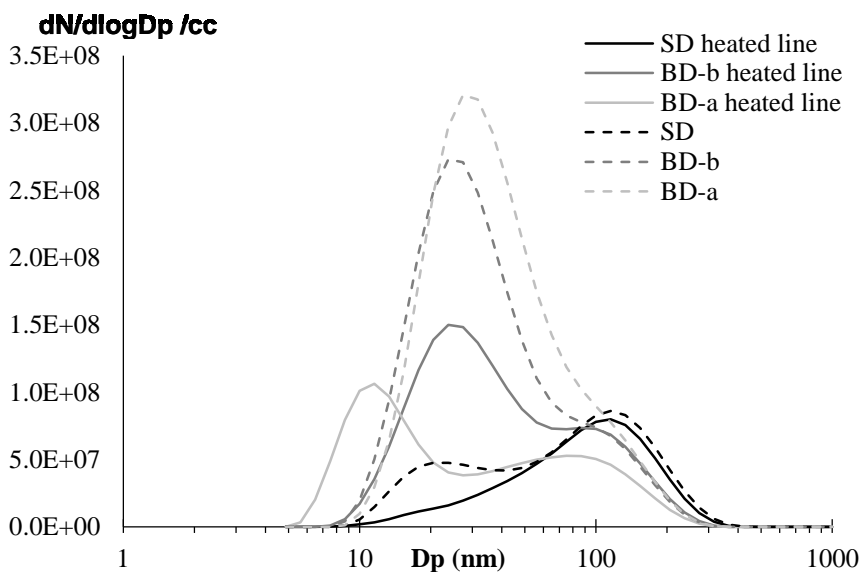

Figure 15. Particle size distribution measured in the first dilution point with and without the heated sampling line using petro diesel (SD), biodiesel before (BD-b) and after (BD-a) the oil change (based on Figure 3 and 4 in Paper II).

In **Figure 16** the total number concentration for the different sampling points is shown for the accumulation- and nucleation mode separately. It can be seen that the accumulation mode was in general more stable than the nucleation mode which varied significantly between the fuels and sampling points. The measurements in the secondary dilution point (residence chamber) with a residence time (~10 minutes) showed that the concentration in the nucleation mode was lower than in the first dilution stage. This can probably be explained by losses due to coagulation (into the accumulation mode) and to some degree from wall losses in the dilution system as well as possibly also evaporation of semi volatile nucleation mode particles. Compared to measurements in the raw exhaust, the total number concentration was higher and a clear nucleation mode was present for BD in both before (BD-b) and after (BD-a) the oil exchange.

In addition, it can be observed that particle number concentration of the accumulation mode is considerably increased for BD-a without the heated line, which is rather unlikely and not supported by the size distribution data, and instead probably explained by the mode fitting algorithm in the

DMS over estimating the accumulation mode for the BD particle emissions.

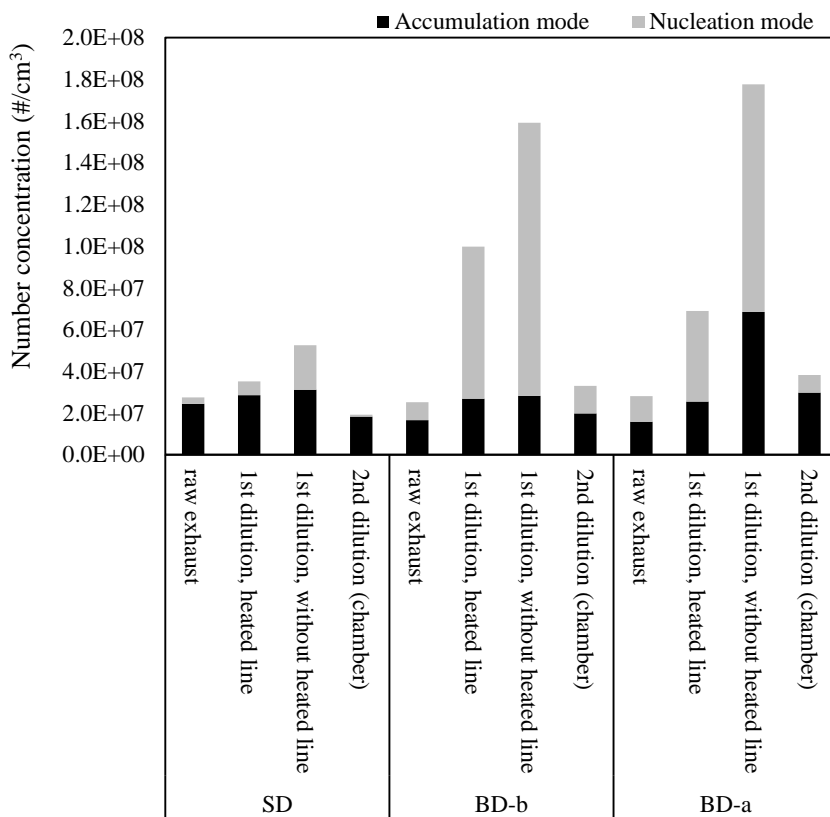

Figure 16. Total particle number concentration in the exhaust emissions and at different sampling points in the whole set-up, split into nucleation and accumulation mode using petro diesel (SD), biodiesel before (BD-b) and after (BD-a) the oil change. Adapted from Figure 6 in Paper II.

Paper III

A novel chamber set-up for human exposures of biomass combustion aerosols was described and evaluated. The evaluation of the systems function was performed under different conditions and examples with data from three earlier performed human exposure campaigns were discussed.

During the evaluation the losses of the fine particles in the chamber was determined to be reasonable low (~9%), presumable caused by coagulation and/or by losses of the smallest particle fraction to the walls in the chamber. The mixing conditions in the chamber was also investigated and it was found that with a small fan operating at low velocity, adequate mixing was ensured. From the data collected during the earlier performed exposure studies it could be seen that in general it was possible to keep the target mass concentrations (measured online with the use of a TEOM) inside the chamber at the aimed level for emissions generated by a wood stove and a pellet boiler, respectively, as shown in **Figure 17**. For the wood stove case, this is of special relevance sine the combustion conditions, and thus the emissions, during these experiments was highly variable in the primary flue gases. For the case with the pellet boiler, the combustion and aerosol emission was more stable, which is reflected by less variation in average concentration in the chamber with a narrower SD. In addition, it was also proved that it was possible to get clearly different aerosols from these two combustion appliances as illustrated in **Figure 18** for the particle number size distribution.

Based on the evaluation of function and present exposure experiences it was concluded that the chamber set-up and biomass aerosol generation systems is able to produce a stable aerosol concentration in the chamber of different particle types. Showing that the described human exposure setup for biomass combustion aerosols together with the integrated biomass combustion laboratory gives extensive possibilities for designing different whole body human exposure as well as other aerosol research studies for a variety of biomass combustion aerosols.

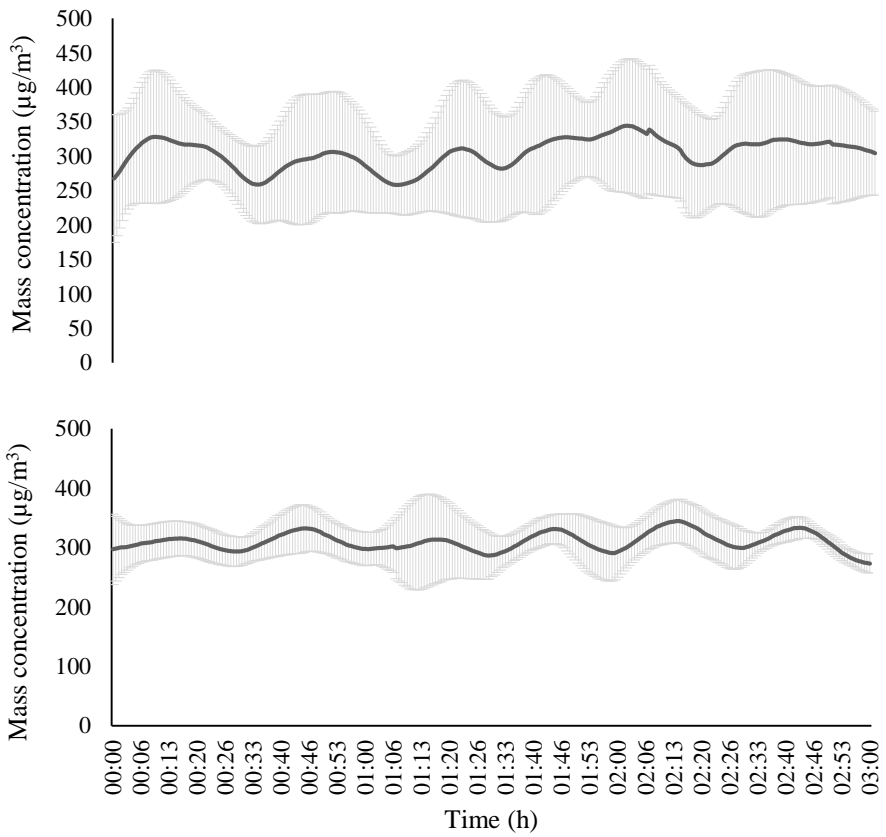

Figure 17. Average online PM_1 mass concentration (measured with TEOM) of included exposures in one of the wood stove (upper) and pellet boiler (lower) studies with SD given as error bars at each time point. Adapted from Figure 5 in Paper III.

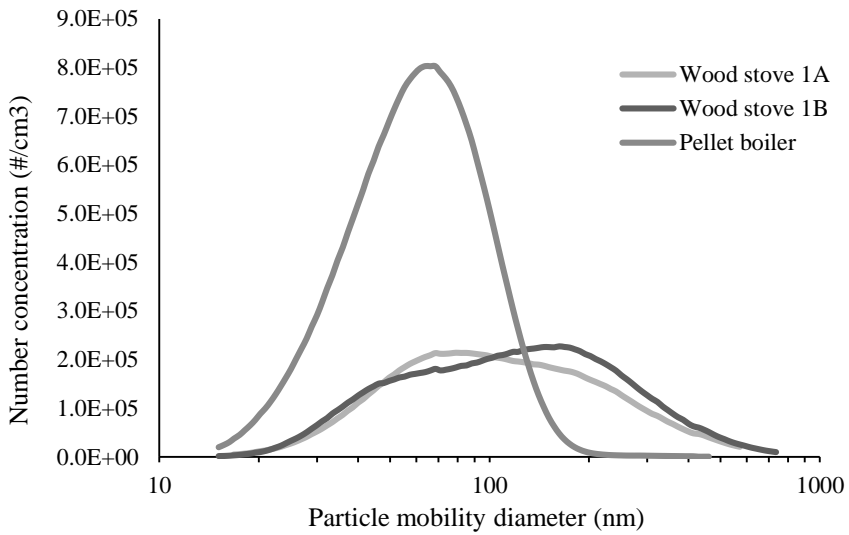

Figure 18. Particle size distribution for three different biomass combustion aerosols inside the chamber during exposure studies performed with the evaluated setup. Adapted from Figure 6 in Paper III.

Paper IV

In this paper whole batch emissions from a conventional wood stove using four types of logs (birch, spruce, pine, aspen) at two different combustion conditions; nominal (NB) and high (HB) burn rate were investigated. Particles for offline analysis were collected as well as online measurements of flue gas (i.e. O₂, CO, NO) and particle properties (i.e. PN and particle size distribution). Offline chemical characterization of filter samples was performed including carbon fractioning (OC/EC), PAH, oxy-PAH and major inorganic ions.

The overall influence of wood stove operation on the emissions that was observed, was rather expected based on previous studies, but was here more thoroughly explored and summarized in **Figure 19**. It was found that the fuel somewhat influenced the emissions, especially for the inorganic ash particles where the content in the fuel was found to be the main determining factor (as seen by the increased emissions of alkali salts for aspen).

The difference between the burning conditions was seen by the considerably elevated carbonaceous particle emissions (soot and organics) that were found during high burn rate conditions. But in some cases, as for pine, the specific fuel properties affected the combustion performance and in this way also influenced particle and PAH emissions. It was found that the oxy-PAH/PAH ratio during HB was increased, suggesting an enrichment of particulate oxy-PAHs, information that can be of relevance when assessing the toxicological properties of the PM from different sources (e.g. residential heating, traffic, etc.).

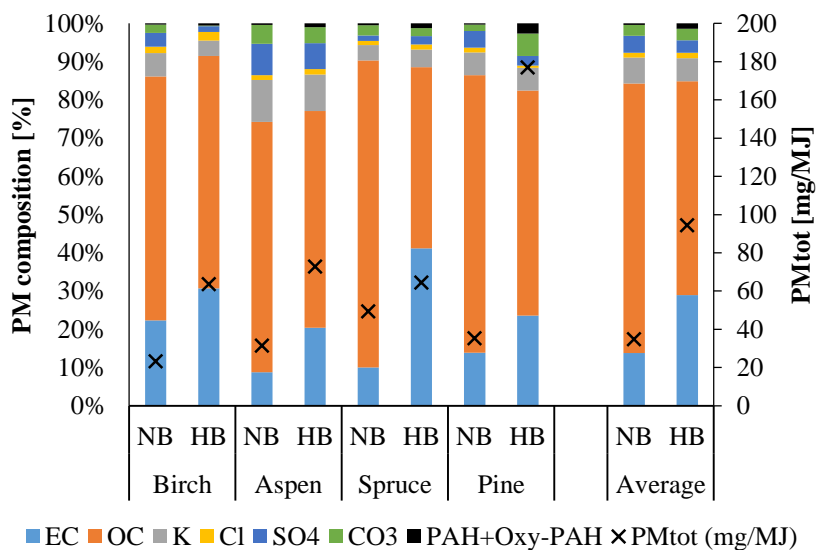

Figure 19. Composition of PM (primary axis) shown as relative abundance of components analysed, i.e. EC, OC, PAH, Oxy-PAH and inorganic ions (K^+ , Cl^- , SO_4^{2-} , and CO_3^{2-}) for the four different fuels at the two different burning conditions. CO_3^{2-} was calculated based on the ratio $K^+ / (Cl^- + 2SO_4^{2-})$ to balance the cation/anion ratio. In addition, total PM emission is also shown (secondary axis). Reprinted from Paper IV.

Paper V

In this paper whole batch sampling of particles for offline characterization of particulate hydroxylated polycyclic aromatic hydrocarbons (OH-PAH) and PAH were collected from a conventional wood stove using four types of logs (birch, spruce, pine, aspen) at two different combustion conditions; nominal (NB) and high (HB) burn rate. OH-PAH are oxidation products of PAH, and have not been studied as much as PAH, but have been found to have toxic and carcinogenic properties. The primary source is assumed to be from combustion [88]. Therefore, analysis of 9 OH-PAH and 2 hydroxy biphenyls was performed on the collected particles.

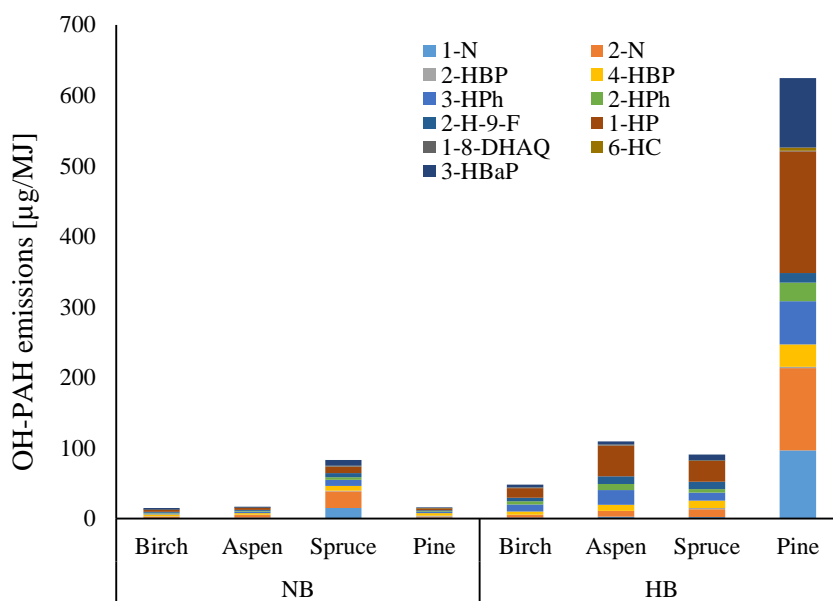

Figure 20. OH-PAH emissions from different wood types combusted at two combustion conditions. Reprinted from Paper V.

OH-PAH (**Figure 20**) and PAH (**Figure 21**) emissions was in this study found to vary significantly with the use of different wood types during the two burning conditions. Emissions from NB corresponded on average to 15% of the emissions from HB, with average emissions of $32.5 \mu\text{g}/\text{MJ}_{\text{fuel}}$ for NB and $218 \mu\text{g}/\text{MJ}_{\text{fuel}}$ for HB. The PAH emissions were also higher in HB samples compared to NB samples for all the fuels. The average emissions for all of the 45 PAHs analysed were for NB 79.4 and 966

$\mu\text{g}/\text{MJ}_{\text{fuel}}$ for HB. The NB emissions corresponded on average to 18% of the emissions from HB.

Emissions of the measured OH-PAH corresponded on average to 32% of PAH, indicating the importance of further investigation into the formation, occurrence and distribution of these compounds as they are present in significant amounts in wood smoke particles. This clear general influence of burning conditions seen in this study, are in line with previous studies using the same stove model [31, 89], although not previously reported for OH-PAH.

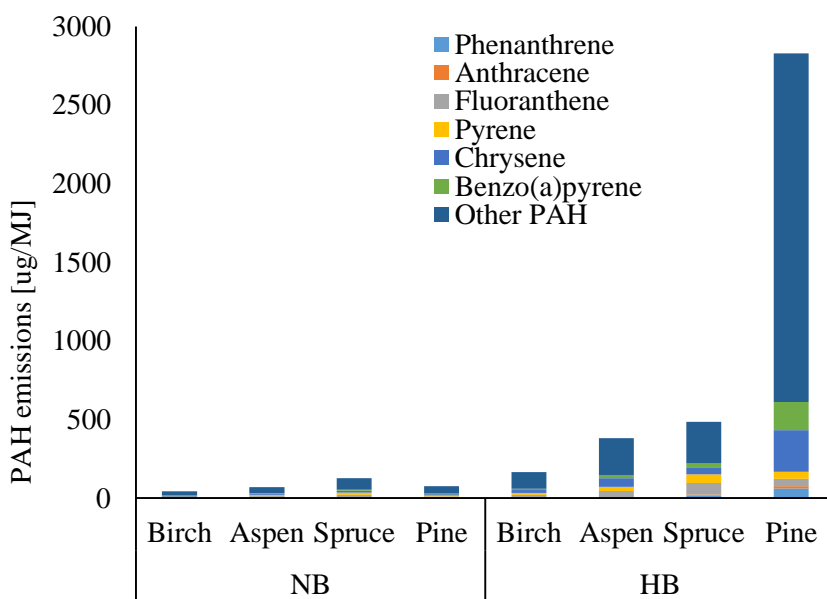

Figure 21. PAH emissions from the different wood types used combusted at two combustion conditions. The 6 most abundant PAHs of the 45 PAH analysed is presented in the figure while the rest are grouped into “Other PAH”. Reprinted from Paper V.

Paper VI

In this paper an AMS was used for high time resolution measurements of emissions from whole batch combustion of birch logs at two burn rates (NB and HB) in a conventional wood stove. The AMS data was combined with on-line monitoring of O₂ and CO in the flue gases, giving total organic material (OA) data, including PAHs, directly linked to combustion conditions. Filter sampling of particles for total PM mass concentration and carbon fractioning analysis were also performed. The combustion cycle during both NB and HB was in this study separated into three phases:

1. “Fuel addition”, which starts when fuel is added on the glowing embers of the preceding cycle and lasts until the flue gas O₂ content drops below 9%.
2. “Intermediate” phase, that follows after the initial fuel addition phase and includes the whole continuous flaming phase, and finally
3. “Burn out” phase, starting when the O₂ content rises above 14%

It was found that, during fuel addition, a burst of OA occurred during both NB and HB (see **Figure 22**). In the intermediate phase at NB relatively low PAH and OA was emitted, but during HB the emissions of PAH was considerably increased. When examining the period of higher PAH emissions during HB, it can be seen that it occurs when O₂ is low and CO is elevated. The burn out phase was associated with low emissions of both OA and PAHs.

In addition, a separate experiment was carried out where a small batch of additional wood was added to the later parts of the intermediate phase during HB. This procedure prolonged the cycle with “overload” episodes of fuel rich conditions at high temperatures with low O₂ levels causing very high PAH emissions. Under these conditions, the PAH to OA ratio increased with maximums of 40% PAH, with a moderate increase in OA.

The highest OA emissions were found during the addition of fuel on glowing embers. PM emission values was found to be ~40 mg/MJ for NB and ~80 mg/MJ for HB, with carbon fractioning giving a EC/OC ratio of 0.1 during fuel addition at HB and 3.5 for a full HB cycle. This indicates that the EC emissions are co-emitted with PAHs during hot air starved conditions.

In this study it was seen that the hot and air-starved conditions occurring during the intermediate phase at HB favoured PAH emissions. It was also shown that excessively high heat release rates are undesirable, because of the increased emissions of particulate PAHs. While the specific emissions values found are stove-specific, the observed phenomenon is (qualitatively) likely not.

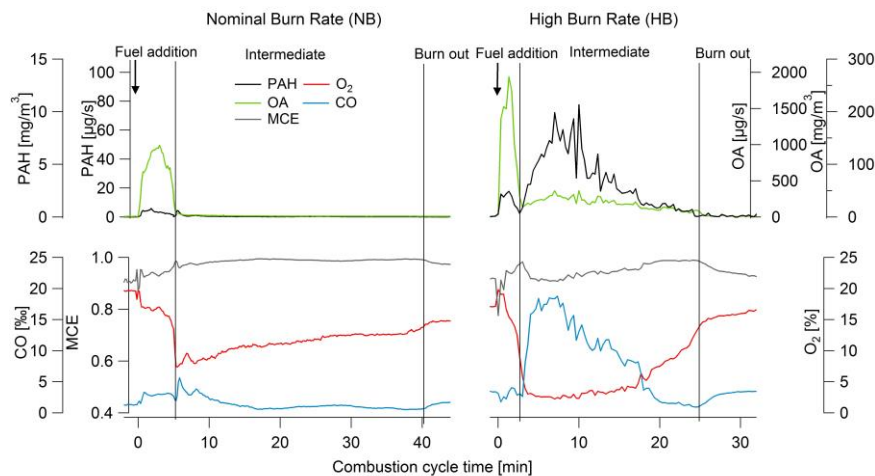

Figure 22. Time series of PAH and OA emissions from nominal (left), and high (right) burn rate wood stove experiments. $t = 0$ marks the start of a combustion cycle. Vertical lines mark the combustion phases; arrows indicate fuel additions. Top panel: measured mass concentrations accounting for dilution. Due to the constant flow rate through the stove, these are proportional to emissions in $\mu\text{g/s}$. Middle panel: modified combustion efficiency (MCE). Bottom panel: flue gas O_2 and CO content. Note the different y-axes: PAHs, MCE, and CO on the left axes, OA and O_2 on the right axis. Reprinted from Paper VI.

Paper VII

In this paper emission from the wood stove used in the earlier papers were exposed to ozone in order to study changes on toxicological responses from ozone initiated ageing (also called dark ageing) on emitted biomass particles from two combustion conditions: nominal (NOM) and hot air starved (HAS). The fuel used was birch logs. Sampling of PM was performed from the chamber set-up described in Paper III in which diluted wood smoke emissions was collected. After the chamber was filled, a first batch of filter sampling was performed from the fresh emissions, and afterwards ozone was added to the chamber and the next batch of filters were sampled. PM for toxicological analysis was collected with the use of a 5 stage gravimetric impactor. In addition, filter sampling for carbon fractioning and PAH was also performed. The HAS conditions used in this study were designed to emit high OA and PAH fraction by having intermittent episodes of “fuel addition” and “overload”, as described in Paper VI.

Clear differences between PAH emissions for NOM and HAS emissions were seen in the fresh samples, with emissions values of PAHs during HAS being four times higher than during NOM. Ageing influenced PAH by generally reducing the total amount when compared to the fresh sample. When comparing the toxicological effects of NOM compared to HAS, a stronger cytotoxic (cell death) effect was found for HAS which was hypothesized to be linked a higher OM (19 and 57%) and PAH (0.1 and 0.4%) fraction. Ageing did not have a clear influence on this parameter, but a slight increase could be seen in one of the doses of aged HAS compared to the fresh HAS. For the inflammatory markers TNF- α and MIP-2, clear dose response relationships were generally found for fresh and aged NOM (except for the highest dose of fresh aerosol) with a slight decrease for the aged PM. The HAS PM had a reduced concentration of inflammatory markers, which can be linked to a high degree of cell death in higher doses and an immunosuppressive effect from the higher PAH content [90].

The largest genotoxicity in this study was from the aged HAS sample, more than twice as high for the fresh sample. This occurred even though the relative fraction of PAHs was lower in the aged sample, which can be explained by a degradation of PAHs during the ageing where they formed oxy- and nitro-PAHs [91].

To summarize, ageing in this study increased genotoxicity, reduced cell viability and the release of inflammatory markers. However, at least for inflammatory markers and cell viability, the largest difference was not between aged and fresh but instead between NOM and HAS.

6. Final remarks and conclusions

Within the two studies included in this thesis on particle emissions and properties from *engine exhaust*, new information has been presented regarding how the emissions may be influenced when introducing biodiesel. In addition, the specific behaviour of RME biodiesel in an existing engine and the influences on the particle emissions under different driving and sampling conditions was explored. In the first study (**Paper I**), exhaust PM from an engine running on biodiesel were extensively characterised. With the introduction of biodiesel, the PM mass concentration was almost halved compared to when petro diesel was used while a shift towards smaller particles was observed. The shift in particle mass and size was associated with less soot and a higher fraction of organic matter in general. Furthermore, considerable less total PAHs was emitted but a relative higher fraction of oxy-PAHs was found, when shifting from petro diesel to biodiesel. As biodiesel is virtually free of PAHs there should be no (or very low) contribution of fuel related PAHs to the exhaust. Still, surprisingly large number of PAHs was found in the biodiesel PM in this study. From earlier research on petro diesel it has been shown that PAHs in the fuel can evaporate and survive the combustion in the engine and be emitted, something that should not happen with biodiesel. Therefore, it can be hypothesized that the PAHs found are probably originating from the lubricating oil.

In a follow up study (**Paper II**), further online measurements of particle size distribution and number concentration was performed to elucidate the differences between petro diesel and biodiesel both in the raw exhaust and in two subsequent sampling points with different dilution ratio. In addition, measurement before and after a lubrication oil exchange was performed. The study clearly illustrated that the formation of the nucleation mode particles (presumably organics) was strongly influenced by the switch to biodiesel, especially at different dilution conditions, while the accumulation mode (presumably soot) were rather constant and more stable. Furthermore, the lubrication oil exchange had a large influence on the nucleation mode particles, enhancing the nucleation even further. Although the presented results are interesting and relevant, both of academic and societal relevance, the work only included measurements on one specific engine and one type of biodiesel. From the literature, it is

known that the exhaust emission performance may vary considerably from case to case, i.e. fuel-engine combinations, as well as be influenced by sampling conditions. Thus, there is a need for further studies using different biodiesels and other liquid biofuels and fuel-engine concepts, both for present and future potential systems.

The most important specific findings from this research regarding the biodiesel exhaust emissions can be summarized as that with a change from petro diesel to RME biodiesel can influence the PM properties, leading to reduced PM mass, higher number concentration, less soot formation, higher organic content, less PAH but higher oxy-PAH/PAH fraction. This increase of organic matter originating from the fuel need more investigation as this is not ordinarily associated with diesel engine exhaust emissions. It can also be concluded that PAH and PAH related compounds in the emissions should probably be more thoroughly investigated when introducing biodiesel in particular, but presumably also for other biofuels. Finally, based on the research performed it can be concluded that the introduction of biodiesel (and potentially other renewable fuels) can in a considerable way change the emission properties. This could have implications for the assessment of exhaust from engines running on biodiesel fuels, especially when introducing biodiesel in existing and older engines.

Particle emissions from *wood combustion* was the focus of the five following studies included in this thesis. The research was conducted under controlled laboratory conditions in an experimental setup, where logs were combusted in a wood stove to elucidate the influence of fuel and operation parameters on particle emissions and specific physicochemical properties.

In **Paper IV and V**, it was found that the major influence on particle emissions was between nominal and high burn rate, with additional, but minor, influences by the four different wood species. The high burn rate was associated with considerably elevated carbonaceous particle emissions (soot and organics), a shift in particle number size distribution (towards a higher fraction of larger particles) and an increase of PAH emissions. It was also concluded that OH-PAH could be an important group of pollutants, earlier excluded when emissions from wood combustion have been characterized and assessed. In **Paper VI** specific combustion phases in a wood stove were studied by on-line aerosol mass spectrometry to investigate time resolved particle composition. Both nominal and high burn

rate conditions were investigated, although only with birch. In this study some critical phases of the batch combustion of wood was identified regarding the emissions of organic aerosols and PAHs. Fuel addition was associated with increased emissions of organic aerosol while considerably increased PAH emissions was seen during the intermediate phase at high burn rate conditions. In **Paper VII**, emissions from different burn rates were aged with the use of ozone (i.e. dark ageing) to evaluate toxicological properties of the PM in cell cultures. Overall, the ageing process resulted in an increased toxicity of some of the measured endpoints. However, it could also be concluded that burning conditions had a significant influence on particle toxicity. Particles from combustion at high burn rates was composed of a high fraction of organics and PAHs, which was associated with a stronger cytotoxic effect.

Furthermore, in **Paper III** an exposure chamber designed for biomass aerosol assessment was presented. This set-up can be used as an important tool to elucidate chemical and toxicological properties from various biomass sources. Based on the evaluation and data from previously performed human exposure studies it was concluded that the novel human exposure set-up for biomass combustion aerosols together with the integrated biomass combustion laboratory gives vast possibilities for whole body human exposures as well as other aerosol research studies for a variety of biomass combustion emissions.

Overall the results from the wood combustion research performed within the scope of this thesis, showed some important considerations regarding both specific particle properties and the influences of different burning conditions and fuels. One major finding, based on several of the included studies, was that a proper operation of a wood stove is of major importance to avoid unfavourable burning condition and elevated emissions of soot and organic particles, regardless of the wood species used. Some specific occasions during the burning phases in batch wise wood combustion were also identified as important for the overall emissions. Hot air starved combustion conditions was specifically found to cause elevated PAH emissions, and should therefore be avoided. In addition, it was also found that organic aerosols emissions were associated with the adding of fuel. The results from this research has given new specific insights into the emissions from wood stoves and should be of relevance for both

technological development of residential appliances, emission testing/certification, information to users and legislation.

7. Future perspectives

Domestic combustion of biomass for heating and cooking is obviously not a new occurrence; it has been around for thousands of years. Still, a great deal of unknown and unexplored information remains to be elucidated, not at least regarding the emissions from different small-scale appliances and combustion conditions using both old and modern technology. This is of high relevance today, since the use of domestic wood burning in Europe is expected to increase even further in the coming years, and become the dominant source of fine particulate emissions. In the traffic sector, other challenges can be identified, where the present drive of introducing new and renewable fuels, e.g. biodiesel, is of special relevance. Still, the potential changes in exhaust particle emissions and their properties is not yet fully understood.

To approach the many challenges, including scientific, associated with the change of the energy- and traffic systems, and to elucidate the particulate air pollution problems from anthropogenic combustion sources in general, the research should be cross-disciplinary in nature. Research fields of e.g. aerosol science, chemistry, medicine and combustion science should be working together to further investigate the specific levels and properties of particles emissions from small scale biomass combustion as well as from new bio based fuels in engines. This would enable more accurate estimations of how these emissions can affect both public health and the climate as more knowledge regarding the physical-, chemical-, and toxicological characteristics are combined.

Acknowledgement

Jag skulle vilja börja med att tacka min handledare Christoffer Boman som givit mig möjligheten att doktorera. Den här tiden har lärt mig otroligt mycket om saker jag inte hade en aning om skulle kunna intressera mig då jag för några år sedan, av en ren slump, fick ett kandidatexamensarbete på TEC-lab (på den tiden ETPC). Efter detta blev jag erbjuden att stanna kvar på avdelningen som projektassistent samtidigt som jag läste min andra examen, för att slutligen bli anställd som doktorand. Jag är ytterst tacksam för allt jag fått chansen att lära mig, alla diverse diskussioner och självfallet också alla konferenser och resor jag fått uppleva under dessa år.

Ett stort tack till alla er som samarbetat med mig från olika delar av landet.

Tack till Ioannis Sadiktsis, Rozanna Avagyan och Roger Westerholm från Stockholms Universitet för all den hjälp ni bidragit med kring PAH. Ett extra stort tack till Ioannis för de många kommentarerna och hjälpen med Paper I.

Jag vill också uttrycka min tacksamhet till Joakim Pagels, Erik Nordin och Axel Eriksson från Ergonomi och Aerosol teknologi vid Lunds Universitet för såväl diskussioner som samarbeten inom flera olika projekt och publikationer.

Ytterligare tack till Anders Blomberg, Thomas Sandström, Jon Unosson, Jenny Bosson Damewood och alla ni andra vid Institutionen för folkhälsa och klinisk medicin vid Umeå Universitet för de olika projekt jag fått privilegiet att delta i tillsammans med er.

Christoffer Boman, Markus Broström och Nils Skoglund förtjänar ett extra stora tack för era kommentarer kring min avhandling, utan er hade den absolut inte sett ut som den gör idag!

Slutligen vill jag tacka alla kollegor som förgyllt min tid vid Umeå Universitet!

References

1. Bernstein, J.A., N. Alexis, C. Barnes, et al., *Health effects of air pollution* Journal of Allergy and Clinical Immunology, 2004. **114**(5): p. 1116-1123.
2. Brunekreef, B. and S.T. Holgate, *Air pollution and health* Lancet, 2002. **360**(9341): p. 1233-1242.
3. Silva, R.A., J.J. West, Y.Q. Zhang, et al., *Global premature mortality due to anthropogenic outdoor air pollution and the contribution of past climate change* Environmental Research Letters, 2013. **8**(3).
4. Phalen, R.F., L.B. Mendez, and M.J. Oldham, *New developments in aerosol dosimetry* Inhalation Toxicology, 2010. **22**: p. 6-14.
5. Intergovernmental panel on climate change (IPCC), *Climate Change 2007: The Physical Science Basis. Contribution of Working Group I to the Fourth Assessment, Report of the Intergovernmental Panel on Climate Change 2007*.
6. Bond, T.C., S.J. Doherty, D.W. Fahey, et al., *Bounding the role of black carbon in the climate system: A scientific assessment* Journal of Geophysical Research-Atmospheres, 2013. **118**(11): p. 5380-5552.
7. Seneca, L.A., *Epistulae morales ad Lucilium*. 65 AD.
8. Brimblecombe, P., *Attitudes and responses towards air-pollution in medieval england* Journal of the Air Pollution Control Association, 1976. **26**(10): p. 941-945.

9. Bell, M.L. and D.L. Davis, *Reassessment of the lethal London fog of 1952: Novel indicators of acute and chronic consequences of acute exposure to air pollution* Environmental Health Perspectives, 2001. **109**: p. 389-394.
10. Dockery, D.W., C.A. Pope, X.P. Xu, et al., *An association between air-pollution and mortality in 6 United-States cities* New England Journal of Medicine, 1993. **329**(24): p. 1753-1759.
11. Laden, F., L.M. Neas, D.W. Dockery, et al., *Association of fine particulate matter from different sources with daily mortality in six US cities* Environmental Health Perspectives, 2000. **108**(10): p. 941-947.
12. Heal, M.R., P. Kumar, and R.M. Harrison, *Particles, air quality, policy and health* Chemical Society Reviews, 2012. **41**(19): p. 6606-6630.
13. Beelen, R., O. Raaschou-Nielsen, M. Stafoggia, et al., *Effects of long-term exposure to air pollution on natural-cause mortality: an analysis of 22 European cohorts within the multicentre ESCAPE project* Lancet, 2014. **383**(9919): p. 785-795.
14. Schauer, J.J., W.F. Rogge, L.M. Hildemann, et al., *Source apportionment of airborne particulate matter using organic compounds as tracers* Atmospheric Environment, 1996. **30**(22): p. 3837-3855.
15. Larson, T.V. and J.Q. Koenig, *Wood smoke - Emissions and noncancer respiratory effects* Annual Review of Public Health, 1994. **15**: p. 133-156.
16. Bolling, A.K., A.I. Totlandsdal, G. Sallsten, et al., *Wood smoke particles from different combustion phases induce similar pro-inflammatory effects in a co-culture of monocyte and pneumocyte cell lines* Particle and Fibre Toxicology, 2012. **9**.

17. Puxbaum, H., A. Caseiro, A. Sanchez-Ochoa, et al., *Levoglucosan levels at background sites in Europe for assessing the impact of biomass combustion on the European aerosol background* Journal of Geophysical Research-Atmospheres, 2007. **112**(D23).
18. Amann, M., I. Bertok, J. Cofala, et al., *Baseline Scenarios for the Clean Air for Europe (CAFE) Programme*. 2005, International Institute for Applied Systems Analysis.
19. Berna, F., P. Goldberg, L.K. Horwitz, et al., *Microstratigraphic evidence of in situ fire in the Acheulean strata of Wonderwerk Cave, Northern Cape province, South Africa* Proceedings of the National Academy of Sciences of the United States of America, 2012. **109**(20): p. E1215-E1220.
20. Boman, C., *Particulate and gaseous emissions from residential biomass combustion*, Doctoral Thesis, 2005, Umeå University
21. Miller, J.A. and C.T. Bowman, *Mechanism and modeling of nitrogen chemistry in combustion* Progress in Energy and Combustion Science, 1989. **15**(4): p. 287-338.
22. Omidvarborna, H., A. Kumar, and D.S. Kim, *NOx emissions from low-temperature combustion of biodiesel made of various feedstocks and blends* Fuel Processing Technology, 2015. **140**: p. 113-118.
23. Zhang, Y. and A.L. Boehman, *Impact of biodiesel on NOx emissions in a common rail direct injection diesel engine* Energy & Fuels, 2007. **21**(4): p. 2003-2012.
24. Lindroos, O., *Residential use of firewood in Northern Sweden and its influence on forest biomass resources* Biomass & Bioenergy, 2011. **35**(1): p. 385-390.

25. Walker, J., *Primary Wood Processing*. 2006: Springer Netherlands.
26. Tissari, J., K. Hytonen, J. Lyyranen, et al., *A novel field measurement method for determining fine particle and gas emissions from residential wood combustion* Atmospheric Environment, 2007. **41**(37): p. 8330-8344.
27. Johansson, L.S., B. Leckner, L. Gustavsson, et al., *Emission characteristics of modern and old-type residential boilers fired with wood logs and wood pellets* Atmospheric Environment, 2004. **38**(25): p. 4183-4195.
28. Dasch, J.M., *Particulate and gaseous emissions from wood-burning fireplaces* Environmental Science & Technology, 1982. **16**(10): p. 639-649.
29. Bolling, A.K., J. Pagels, K.E. Yttri, et al., *Health effects of residential wood smoke particles: the importance of combustion conditions and physicochemical particle properties* Particle and Fibre Toxicology, 2009. **6**.
30. Boman, C., A. Nordin, D. Bostrom, et al., *Characterization of inorganic particulate matter from residential combustion of pelletized biomass fuels* Energy & Fuels, 2004. **18**(2): p. 338-348.
31. Pettersson, E., C. Boman, R. Westerholm, et al., *Stove performance and emission characteristics in residential wood log and pellet combustion, part 2: Wood stove* Energy & Fuels, 2011. **25**: p. 315-323.
32. Brook, R.D., S. Rajagopalan, C.A. Pope, et al., *Particulate matter air pollution and cardiovascular disease: An update to the scientific statement from the American Heart Association* Circulation, 2010. **121**(21): p. 2331-2378.

33. Ghio, A.J., C.B. Smith, and M.C. Madden, *Diesel exhaust particles and airway inflammation* Current Opinion in Pulmonary Medicine, 2012. **18**(2): p. 144-150.
34. Robbins, M., *Fuelling politics* Nature, 2011. **474**(7352): p. S22-S24.
35. Yusuf, N.N.A.N., S.K. Kamarudin, and Z. Yaakub, *Overview on the current trends in biodiesel production* Energy Conversion and Management, 2011. **52**(7): p. 2741-2751.
36. Demirbas, A., *Biodegradability of biodiesel and petrodiesel fuels* Energy Sources Part A: Recovery, utilization and environmental effects, 2009. **31**(2): p. 169-174.
37. Swanson, K.J., M.C. Madden, and A.J. Ghio, *Biodiesel exhaust: The need for health effects research* Environmental Health Perspectives, 2007. **115**(4): p. 496-499.
38. Lapuerta, M., O. Armas, and J. Rodriguez-Fernandez, *Effect of biodiesel fuels on diesel engine emissions* Progress in Energy and Combustion Science, 2008. **34**(2): p. 198-223.
39. Karavalakis, G., E. Bakeas, G. Fontaras, et al., *Effect of biodiesel origin on regulated and particle-bound PAH (polycyclic aromatic hydrocarbon) emissions from a Euro 4 passenger car* Energy, 2011. **36**(8): p. 5328-5337.
40. Karavalakis, G., G. Deves, G. Fontaras, et al., *The impact of soy-based biodiesel on PAH, nitro-PAH and oxy-PAH emissions from a passenger car operated over regulated and nonregulated driving cycles* Fuel, 2010. **89**(12): p. 3876-3883.
41. Bunger, J., J. Krahl, A. Munack, et al., *Strong mutagenic effects of diesel engine emissions using vegetable oil as fuel* Archives of Toxicology, 2007. **81**(8): p. 599-603.

42. Steiner, S., J. Czerwinski, P. Comte, et al., *Comparison of the toxicity of diesel exhaust produced by bio- and fossil diesel combustion in human lung cells in vitro* Atmospheric Environment, 2013. **81**: p. 380-388.
43. Bungler, J., J. Krahl, O. Schroder, et al., *Potential hazards associated with combustion of bio-derived versus petroleum-derived diesel fuel* Critical Reviews in Toxicology, 2012. **42**(9): p. 732-750.
44. Unosson, J., *Acute cardiovascular effects of biofuel exhaust exposure*, Doctoral Thesis, 2014, Umeå University
45. Lighty, J.S., J.M. Veranth, and A.F. Sarofim, *Combustion aerosols: Factors governing their size and composition and implications to human health* Journal of the Air & Waste Management Association, 2000. **50**(9): p. 1565-1618.
46. Wilson, W.E. and H.H. Suh, *Fine particles and coarse particles: Concentration relationships relevant to epidemiologic studies* Journal of the Air & Waste Management Association, 1997. **47**(12): p. 1238-1249.
47. Londahl, J., J. Pagels, C. Boman, et al., *Deposition of biomass combustion aerosol particles in the human respiratory tract* Inhalation Toxicology, 2008. **20**(10): p. 923-933.
48. Hinds, W., *Aerosol Technology: Properties, Behavior, and Measurement of Airborne Particles*. 1982: John Wiley & Sons.
49. Kuempel, E.D., L.M. Sweeney, J.B. Morris, et al., *Advances in Inhalation Dosimetry Models and Methods for Occupational Risk Assessment and Exposure Limit Derivation* Journal of Occupational and Environmental Hygiene, 2015. **12**: p. S18-S40.

50. Sigsgaard, T., B. Forsberg, I. Annesi-Maesano, et al., *Health impacts of anthropogenic biomass burning in the developed world* European Respiratory Journal, 2015. **46**(6): p. 1577-1588.
51. Sippula, O., *Fine particle formation and emissions in biomass combustion*, Doctoral Thesis, 2010, University of Eastern Finland
52. Kittelson, D.B., *Engines and nanoparticles: A review* Journal of Aerosol Science, 1998. **29**(5-6): p. 575-588.
53. Maricq, M.M., *Chemical characterization of particulate emissions from diesel engines: A review* Journal of Aerosol Science, 2007. **38**(11): p. 1079-1118.
54. Robinson, A.L., N.M. Donahue, M.K. Shrivastava, et al., *Rethinking organic aerosols: Semivolatile emissions and photochemical aging* Science, 2007. **315**(5816): p. 1259-1262.
55. Burtscher, H., *Physical characterization of particulate emissions from diesel engines: a review* Journal of Aerosol Science, 2005. **36**(7): p. 896-932.
56. Hallquist, M., J.C. Wenger, U. Baltensperger, et al., *The formation, properties and impact of secondary organic aerosol: current and emerging issues* Atmospheric Chemistry and Physics, 2009. **9**(14): p. 5155-5236.
57. Sakurai, H., H.J. Tobias, K. Park, et al., *On-line measurements of diesel nanoparticle composition and volatility* Atmospheric Environment, 2003. **37**(9-10): p. 1199-1210.
58. Turpin, B.J., P. Saxena, and E. Andrews, *Measuring and simulating particulate organics in the atmosphere: problems and prospects* Atmospheric Environment, 2000. **34**(18): p. 2983-3013.

59. Pöschl, U., *Atmospheric aerosols: Composition, transformation, climate and health effects* Angewandte Chemie-International Edition, 2005. **44**(46): p. 7520-7540.
60. Haynes, B.S. and H.G. Wagner, *Soot formation* Progress in Energy and Combustion Science, 1981. **7**(4): p. 229-273.
61. Bockhorn, H., *Soot Formation in Combustion*. 1994: Springer-Verlag Berlin Heidelberg.
62. Kocbach, A., B.V. Johansen, P.E. Schwarze, et al., *Analytical electron microscopy of combustion particles: a comparison of vehicle exhaust and residential wood smoke* Science of the Total Environment, 2005. **346**(1-3): p. 231-243.
63. Petzold, A., J.A. Ogren, M. Fiebig, et al., *Recommendations for reporting "black carbon" measurements* Atmospheric Chemistry and Physics, 2013. **13**(16): p. 8365-8379.
64. Bond, T.C. and R.W. Bergstrom, *Light absorption by carbonaceous particles: An investigative review* Aerosol Science and Technology, 2006. **40**(1): p. 27-67.
65. Intergovernmental panel on climate change (IPCC), *Climate change 1995: The science of climate change*. 1996: University Press, Cambridge.
66. Turpin, B.J. and H.J. Lim, *Species contributions to PM_{2.5} mass concentrations: Revisiting common assumptions for estimating organic mass* Aerosol Science and Technology, 2001. **35**(1): p. 602-610.
67. Japar, S.M., A.C. Szkarlat, R.A. Gorse, et al., *Comparison of solvent-extraction and thermal optical carbon analysis-methods - Application to diesel vehicle exhaust aerosol* Environmental Science & Technology, 1984. **18**(4): p. 231-234.

68. Kampa, M. and E. Castanas, *Human health effects of air pollution* Environmental Pollution, 2008. **151**(2): p. 362-367.
69. Li, N., C. Sioutas, A. Cho, et al., *Ultrafine particulate pollutants induce oxidative stress and mitochondrial damage* Environmental Health Perspectives, 2003. **111**(4): p. 455-460.
70. Kubatova, A., L.C. Dronen, M.J. Picklo, et al., *Midpolarity and nonpolar wood smoke particulate matter fractions deplete glutathione in RAW 264.7 macrophages* Chemical Research in Toxicology, 2006. **19**(2): p. 255-261.
71. Yu, H.T., *Environmental carcinogenic polycyclic aromatic hydrocarbons: photochemistry and phototoxicity* Journal of Environmental Science and Health Part C-Environmental Carcinogenesis & Ecotoxicology Reviews, 2002. **20**(2): p. 149-183.
72. Pedersen, D.U., J.L. Durant, B.W. Penman, et al., *Human-cell mutagens in respirable airborne particles in the northeastern United States. I. Mutagenicity of fractionated samples* Environmental Science & Technology, 2004. **38**(3): p. 682-689.
73. Lee, M.L., M.V. Novotny, and K.D. Bartle, *Analytical Chemistry of Polycyclic Aromatic Compounds*. 1981: Academic Press, Inc.
74. Shen, H.Z., Y. Huang, R. Wang, et al., *Global atmospheric emissions of polycyclic aromatic hydrocarbons from 1960 to 2008 and future predictions* Environmental Science & Technology, 2013. **47**(12): p. 6415-6424.
75. Wiinikka, H., R. Gebart, C. Boman, et al., *Influence of fuel ash composition on high temperature aerosol formation in fixed bed combustion of woody biomass pellets* Fuel, 2007. **86**(1-2): p. 181-193.

76. Bostrom, D., N. Skoglund, A. Grimm, et al., *Ash Transformation Chemistry during Combustion of Biomass* Energy & Fuels, 2012. **26**(1): p. 85-93.
77. Sippula, O., K. Hytonen, J. Tissari, et al., *Effect of wood fuel on the emissions from a top-feed pellet stove* Energy & Fuels, 2007. **21**(2): p. 1151-1160.
78. Vassilev, S.V., D. Baxter, L.K. Andersen, et al., *An overview of the composition and application of biomass ash. Part 1. Phase-mineral and chemical composition and classification* Fuel, 2013. **105**: p. 40-76.
79. Vassilev, S.V., D. Baxter, and C.G. Vassileva, *An overview of the behaviour of biomass during combustion: Part II. Ash fusion and ash formation mechanisms of biomass types* Fuel, 2014. **117**: p. 152-183.
80. Lombaert, K., S. Morel, L. Le Moyne, et al., *Nondestructive analysis of metallic elements in diesel soot collected on filter: Benefits of laser induced breakdown spectroscopy* Plasma Chemistry and Plasma Processing, 2004. **24**(1): p. 41-56.
81. Betha, R. and R. Balasubramanian, *Emissions of particulate-bound elements from biodiesel and ultra low sulfur diesel: Size distribution and risk assessment* Chemosphere, 2013. **90**(3): p. 1005-1015.
82. Liati, A., D. Schreiber, P.D. Eggenschwiler, et al., *Metal Particle Emissions in the Exhaust Stream of Diesel Engines: An Electron Microscope Study* Environmental Science & Technology, 2013. **47**(24): p. 14495-14501.
83. DeCarlo, P.F., J.R. Kimmel, A. Trimborn, et al., *Field-deployable, high-resolution, time-of-flight aerosol mass spectrometer* Analytical Chemistry, 2006. **78**(24): p. 8281-8289.

84. Sadiktsis, I., J.H. Koegler, T. Benham, et al., *Particulate associated polycyclic aromatic hydrocarbon exhaust emissions from a portable power generator fueled with three different fuels - A comparison between petroleum diesel and two biodiesels* Fuel, 2014. **115**: p. 573-580.
85. Dzepina, K., J. Arey, L.C. Marr, et al., *Detection of particle-phase polycyclic aromatic hydrocarbons in Mexico City using an aerosol mass spectrometer* International Journal of Mass Spectrometry, 2007. **263**(2-3): p. 152-170.
86. Lyyranen, J., J. Jokiniemi, E.I. Kauppinen, et al., *Comparison of different dilution methods for measuring diesel particle emissions* Aerosol Science and Technology, 2004. **38**(1): p. 12-23.
87. Cavalli, F., M. Viana, K.E. Yttri, et al., *Toward a standardised thermal-optical protocol for measuring atmospheric organic and elemental carbon: the EUSAAR protocol* Atmospheric Measurement Techniques, 2010. **3**(1): p. 79-89.
88. Vione, D., S. Barra, G. De Gennaro, et al., *Polycyclic aromatic hydrocarbons in the atmosphere: monitoring, sources, sinks and fate. II: Sinks and fate* Annali di Chimica, 2004. **94**(4): p. 257-268.
89. Eriksson, A.C., E.Z. Nordin, R. Nystrom, et al., *Particulate PAH Emissions from Residential Biomass Combustion: Time-Resolved Analysis with Aerosol Mass Spectrometry* Environmental Science & Technology, 2014. **48**(12): p. 7143-7150.
90. van Grevenynghe, J., S. Rion, E. Le Ferrec, et al., *Polycyclic aromatic hydrocarbons inhibit differentiation of human monocytes into macrophages* Journal of Immunology, 2003. **170**(5): p. 2374-2381.

91. Bruns, E.A., M. Krapf, J. Orasche, et al., *Characterization of primary and secondary wood combustion products generated under different burner loads* Atmospheric Chemistry and Physics, 2015. **15**(5): p. 2825-2841.